

CBN430.2 / CBN431.2 / CBN432.2 / CBN433.2 / CBN434.2
Temperature Sensor Connection Cable
User's Guide



Copyright

The data in this document may not be altered or amended without special notification from ETAS GmbH. ETAS GmbH undertakes no further obligation in relation to this document. The software described in it can only be used if the customer is in possession of a general license agreement or single license. Using and copying is only allowed in concurrence with the specifications stipulated in the contract.

Under no circumstances may any part of this document be copied, reproduced, transmitted, stored in a retrieval system or translated into another language without the express written permission of ETAS GmbH.

© **Copyright 2016** ETAS GmbH, Stuttgart

The names and designations used in this document are trademarks or brands belonging to the respective owners.

CBN43x.2 - User's Guide R06 EN - 02.2016

Contents

| | | |
|--------------|---|----|
| 1 | General | 5 |
| 1.1 | Basic Safety Instructions | 5 |
| 1.1.1 | Labeling of Safety Instructions | 5 |
| 1.1.2 | General safety information | 5 |
| 1.1.3 | Requirements for users and duties for operators | 5 |
| 1.1.4 | Correct Use | 5 |
| 1.2 | RoHS conformity | 6 |
| 1.2.1 | European Union | 6 |
| 1.2.2 | China | 6 |
| 1.3 | CE labeling | 6 |
| 1.4 | Product return and recycling | 7 |
| 1.5 | Product labeling | 7 |
| 1.6 | About this manual | 8 |
| 1.6.1 | Structure | 8 |
| 1.6.2 | Using the manual | 8 |
| 1.7 | Scope of delivery | 8 |
| 1.8 | Additional information | 9 |
| 2 | Hardware Description | 11 |
| 2.1 | Overview | 11 |
| 2.1.1 | Field of application and product variants | 11 |
| 2.1.2 | Combined use with the ES411.1 A/D module | 12 |
| 2.1.3 | Properties | 12 |
| 2.2 | Assembly and functionality | 14 |
| 2.2.1 | Diagram of Temperature Sensor Connection Cable | 14 |
| 2.2.2 | Splitter cable | 15 |
| 2.2.3 | Measurement channels | 15 |
| 2.2.4 | Measurement lines | 15 |
| 2.2.5 | Operating power | 16 |

| | | |
|--------------|--|----|
| 2.2.6 | Cable identification | 16 |
| 2.2.7 | Serial number | 17 |
| 2.3 | Wiring | 17 |
| 3 | Technical Data | 19 |
| 3.1 | General data | 19 |
| 3.1.1 | Met standards and norms | 19 |
| 3.1.2 | Type test | 19 |
| 3.1.3 | Environmental requirements | 20 |
| 3.1.4 | Cleaning the product | 20 |
| 3.2 | System requirements | 20 |
| 3.2.1 | Hardware | 20 |
| 3.2.2 | Power supply | 21 |
| 3.2.3 | Software | 21 |
| 3.3 | Electrical data | 22 |
| 3.4 | Mechanical data | 23 |
| 3.5 | Measurement line assignment | 25 |
| 3.6 | Assignment of measurement lines | 25 |
| 3.6.1 | Measurement lines on the CBN43x.2 cable measurement channels | 25 |
| 3.6.2 | Measurement lines with direct connection to the ES411.1 (CBN431.2, CBN433.2) | 26 |
| 4 | Ordering Information | 27 |
| 4.1 | CBN430.2 | 27 |
| 4.2 | CBN431.2 | 27 |
| 4.3 | CBN432.2 | 27 |
| 4.4 | CBN433.2 | 28 |
| 4.5 | CBN434.2 | 28 |
| 4.6 | Calibration Service | 28 |
| 5 | ETAS Contact Addresses | 29 |
| | Figures | 31 |
| | Index | 33 |

1 General

The introductory chapter informs you about the basic safety information, product return and recycling, the use of this manual, the scope of delivery and other information.

1.1 Basic Safety Instructions

1.1.1 Labeling of Safety Instructions

The safety instructions contained in this manual are shown with the standard danger symbol shown below:



The following safety instructions are used. They provide extremely important information. Please read this information carefully.

**CAUTION!**

indicates a low-risk danger which could result in minor or less serious injury or damage if not avoided.

1.1.2 General safety information

Please observe the product safety advice ("ETAS Safety Advice") and the subsequent safety instructions to avoid any impact on your health or damages to the device.

Note

Carefully read the documentation that belongs to the product prior to the startup.

ETAS GmbH does not assume any liability for damages resulting from improper handling, unintended use or non-observance of the safety precautions.

1.1.3 Requirements for users and duties for operators

The product may be assembled, operated and maintained only if you have the necessary qualification and experience for this product. Improper use or use by a user without sufficient qualification can lead to damages or injuries to one's health or damages to property.

General safety at work

The existing regulations for safety at work and accident prevention must be followed.

1.1.4 Correct Use

This product has been developed and released for use in automotive applications. For usage in other domains please contact your ETAS representative.

Requirements for Operation

The following requirements are necessary for safe operation:

- Prior to assembly and operation, observe the notes for environmental requirements (see chapter 3.1.3 on page 20).
- Ensure compliance with the connected and settings values (see chapter 3.2.2 on page 21).



WARNING!

This is a class A product. In a domestic environment this product may cause radio interference in which case the user may be required to take adequate measures.

Requirements for the technical State of the Product

The product is designed in accordance with state-of-the-art technology and recognized safety rules. The product may be operated only in a technically flawless condition and according to the intended purpose and with regard to safety and dangers as stated in the respective product documentation. If the product is not used according to its intended purpose, the protection of the product may be impaired.

Maintenance and cleaning

The product is maintenance-free. For cleaning, use a clean and dry cloth.

1.2 RoHS conformity

1.2.1 European Union

The EU Directive 2002/95/EU limits the use of certain dangerous materials for electrical and electronic devices (RoHS conformity).

ETAS confirms that the product corresponds to this directive which is applicable in the European Union.

1.2.2 China

ETAS confirms that the product meets the product-specific applicable guidelines of the China RoHS (Management Methods for Controlling Pollution Caused by Electronic Information Products Regulation) applicable in China with the China RoHS marking affixed to the product or its packaging.

1.3 CE labeling

ETAS confirms that the product meets the product-specific, applicable European guideline with a CE label on the product or its packaging. CE conformity declaration for the product is available upon request.

1.4 Product return and recycling

The European Union (EU) issued the Waste Electrical and Electronic Equipment (WEEE) Directive to ensure the setup of systems for collecting, handling and processing electronic waste in all countries of the EU.

This ensures that the equipment is recycled in a resource-saving manner that does not represent any risk for the health and safety of humans and the environment.



Fig. 1-1 WEEE symbol

The WEEE symbol (see Fig. 1-1 on page 7) on the product or its packaging indicates that the product may not be disposed of with regular trash.





The user is obligated to separate the waste equipment and to provide it to the WEEE return system for reuse.

The WEEE guidelines apply to all ETAS devices, but not external cables or batteries.

Additional information on the ETAS GmbH recycling program is available from the ETAS sales and service department (see chapter 5 on page 29).

1.5 Product labeling

The following symbols are used for product labeling:

| Symbol | Description |
|---|---|
|  | Prior to operating the product, be sure to read the user's guide! |
|  | Labeling for RoHS (EU), see chapter 1.2.1 on page 6 |
|  | Labeling for CE conformity, see chapter 1.3 on page 6 |
|  | Labeling for RoHS (China), see chapter 1.2.2 on page 6 |

Please observe the information in chapter "Technical Data" on page 19.

1.6 About this manual

This manual describes the operational and technical data for the Temperature Sensor Connection Cable CBN43x.2.

1.6.1 Structure

This manual consists of four chapters and an index.

- **Chapter 1: "Introduction"**

The "Introduction" chapter (this chapter) provides you with information on basic safety notices, product return and recycling, how to use this manual, notes on the scope of delivery, and additional information.

- **Chapter 2: "Hardware Description"**

In the "Hardware Description" chapter you'll find an overview of product variants for the Temperature Sensor Connection Cable CBN43x.2, information on combined implementation with the ES411.1 A/D module, the housing, connections, measurement channels, power supply, cable identification, serial number, as well as wiring.

- **Chapter 3: "Technical Data"**

The "Technical Data" chapter describes the standards and norms met, the environmental requirements, system prerequisites for operation of the Temperature Sensor Connection Cable CBN43x.2, electrical and mechanical data, assignment of measurement channels, and measurement line labeling.

- **Chapter 4: "Ordering Information"**

In the "Ordering Information" chapter you'll find information for ordering the Temperature Sensor Connection Cable.

The concluding chapter "ETAS Contacts" provides you with information on international ETAS sales and service offices.

1.6.2 Using the manual

Typographical conventions

The following typographical conventions are used:

| | |
|----------------|---------------------------------|
| Bold | Device labeling |
| <i>Italics</i> | Particularly important sections |

Important notes for the user are displayed as follows:

Note

Important note for user.

1.7 Scope of delivery

Before initial operation of your CBN43x.2, please verify that the device was delivered with all necessary parts (see chapter 4 on page 27).

1.8 Additional information

The configuration instructions for the Temperature Sensor Connection Cable CBN43x.2 under INCA can be found in the corresponding software documentation.

2 Hardware Description

In the chapter "Hardware Description" you will find an overview of the Temperature Sensor Connection Cable CBN43x.2 product variants, information on the combined use with the ES411.1 A/D module, housing, connections, measurement channels, power supply, cable identification, serial number, as well as wiring.

2.1 Overview

2.1.1 Field of application and product variants

During vehicle development, precise temperature measurement and monitoring is necessary. For example, in hybrid and electric vehicles, the temperatures of the electric motor, the inverter, radiator, batteries, fuel, or associated radiator must be measured exactly during assembly.

If platinum temperature sensors are used for these measurements, more exact temperatures can be obtained with higher resolution by selecting the Pt1xxx temperature sensor and the 4-wire measurement processes.

The Temperature Sensor Connection Cable CBN43x.2 were designed for connecting platinum temperature sensors. They are offered in five product variants/designs:

- 4 thermo-channels (CBN430.2, CBN432.2, CBN434.2)
- 2 thermo-channels plus two analog input channels directly on the ES411.1 (CBN431.2, CBN433.2)

| Temperature Sensor Connection Cable Type | Temperature Sensor | | Input Channel |
|--|--------------------|--------|-------------------------|
| | Type | Number | Directly on the ES411.1 |
| CBN430.2 | Pt100 | 4 | - |
| CBN431.2 | Pt100 | 2 | 2 |
| CBN432.2 | Pt200 | 4 | - |
| CBN433.2 | Pt200 | 2 | 2 |
| CBN434.2 | Pt1000 | 4 | - |

Note

Description, properties, and technical data in this manual apply to all variants of the Temperature Sensor Connection Cable (CBN430.2, CBN431.2 and CBN432.2, CBN433.2, CBN434.2), insofar as not otherwise noted. The shared abbreviation "CBN43x.2" is used in these text components.

Note

The Temperature Sensor Connection Cable CBN430.2, CBN432.2, and CBN434.2 are mechanically identical. The Temperature Sensor Connection Cable CBN431.2, and CBN433.2 are mechanically identical.

Note

The Temperature Sensor Connection Cable CBN43x.2 is intended for use with temperature sensors according to DIN EN 60751.

2.1.2 Combined use with the ES411.1 A/D module

The Temperature Sensor Connection Cable CBN43x.2 consists of two or four identical active temperature measurement channels, depending on product variation, which are integrated into a splitter cable and intended for the combined use with the ES411.1 A/D module.

Combination with the Temperature Sensor Connection Cable expands the channels of the ES411.1 modules for precise temperature measurement, for example in vehicle systems.

ES411.1 module functionality

The ES411.1 module assumes the following functions when used in combination with the CBN43x.2 sensor cable:

- Temperature Sensor Connection Cable CBN43x.2 power supply,
- Measurement power supply for connected 4-wire thermo-sensors to the temperature measurement channels,
- Power supply for additional connected sensors (only CBN431.2 and CBN433.2 sensor cables),
- A/D conversion of measurement values
- Time-synced transfer of the measurement values to a PC or the application program.

The automatic setting of the measurement range prevents error measurements due to incorrect configuration.

Integration into the ETAS measurement system

Integration of the Temperature Sensor Connection Cable CBN43x.2 in the ETAS measurement system and INCA provides an efficient solution for the collection of temperatures during development, application, and validation of electronic control of electrical drives and loads with high power consumption.

2.1.3 Properties

The most important properties of the Temperature Sensor Connection Cable with CBN43x.2 sensor supply combined with the ES411.1 module:

- Compact measurement probes for precise collection of temperatures using platinum temperature sensors with 4-connector connection
- Use in combination with the ES411.1 A/D module
- Measurement power supply of connected 4-wire temperature sensors on the temperature measurement channels integrated in the measurement cable
- Product variants with 2 or 4 measurement channels for different temperature sensors:
 - 4 thermo-channels (CBN430.2, CBN432.2, CBN434.2)

- 2 thermo-channels plus two analog input channels directly on the ES411.1 (CBN431.2, CBN433.2)
- Product variants for platinum temperature sensors with nominal values of 100, 200, and 1000 Ohm
- when using ETAS application software
 - Automatic setting of voltage supply for the Temperature Sensor Connection Cable through the ES411.1 A/D module,
 - Automatic transfer of individual alignment and calibration values for the combination of Temperature Sensor Connection Cable and ES411.1 module,
 - Automatic setting of the measurement range for the Temperature Sensor Connection Cable in INCA
 - Conversion of measured resistance values in temperatures
 - Temperature display in application program
- Synchronized collection of control unit signals and other measurement data from the vehicle environment
- Automotive serviceable product suited for use in development environments and in vehicles on test roads.
 - Adaptable to environmental conditions (temperature, EMC)
 - High mechanical stability and robustness
- Product safety during type testing and certification by an accredited test lab
- together with the ES411.1 module part of the ETAS Tool Suite

Complete technical data for the Temperature Sensor Connection Cable CBN43x.2 can be found in chapter "Technical Data" on page 19.

2.2 Assembly and functionality

2.2.1 Diagram of Temperature Sensor Connection Cable

Note

The Temperature Sensor Connection Cable CBN430.2, CBN432.2, and CBN434.2 are mechanically identical.
 The Temperature Sensor Connection Cable CBN431.2, and CBN433.2 are mechanically identical.

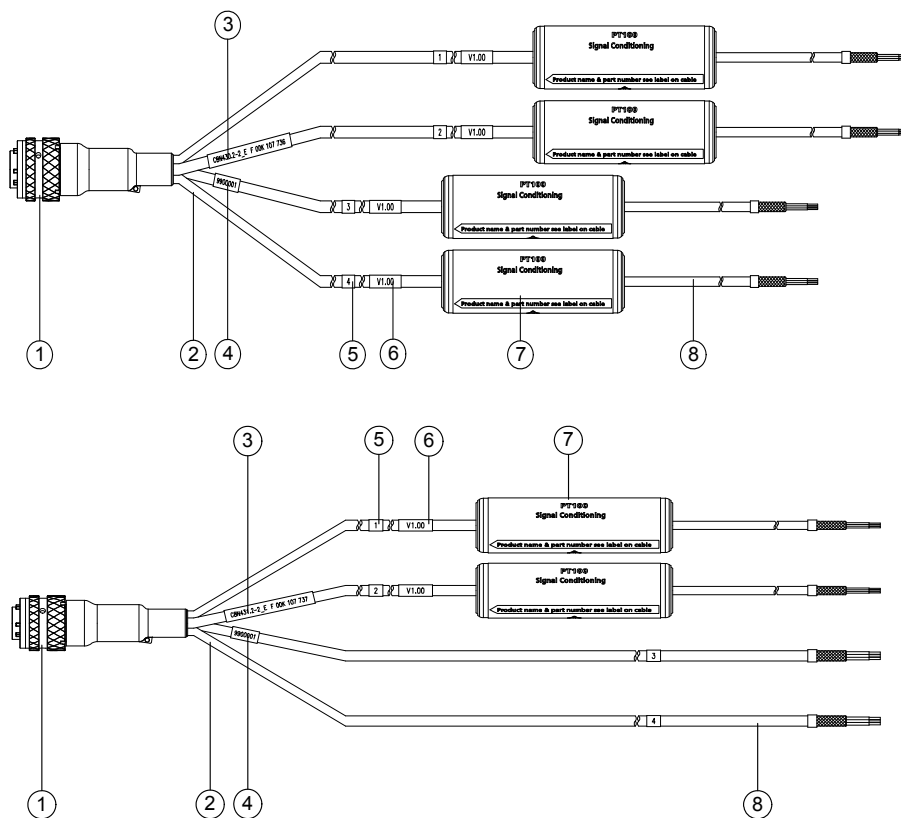

Fig. 2-1 Diagram of the CBN430.2/ CBN432.2/ CBN434.2 (top) and CBN431.2/ CBN433.2 (bottom) sensor cable

| No. in Fig. 2-1 | Designation |
|-----------------|---|
| 1 | Souriau plug |
| 2 | Splitter cable |
| 3 | Product abbreviation and type-parts number |
| 4 | Product serial number |
| 5 | Measurement channel number |
| 6 | Measurement channel hardware version number |
| 7 | Measurement channel housing |
| 8 | Measurement lines |

2.2.2 Splitter cable

The Temperature Sensor Connection Cable CBN43x.2 has a splitter cable on a Souriau plug (left) that is linked with the identical measurement channel housings (middle) or measurement lines for direct connection to the ES411.1.

2.2.3 Measurement channels

The measurement channels are sealed in a separate cylindrical housing containing the measurement channel electronics. The housing is labeled "7" in Fig. 2-1 on page 14.

The supply of measurement current for the temperature sensor connected to this measurement channel and the signal conditioning of the input signals occurs in the measurement channels. With the Temperature Sensor Connection Cable CBN43x.2, the temperatures are measured precisely with 4-wire measurement processes.

Product variation with two or four measurement channels for different temperature sensors are offered:

- 4 measurement channels (CBN430.2, CBN432.2, CBN434.2)
- 2 measurement channels (CBN431.2, CBN433.2)

The measurement channels of the Temperature Sensor Connection Cable CBN43x.2 are mechanically identical. The measurement channels of the Temperature Sensor Connection Cable of a product variation are electrically identical.

2.2.4 Measurement lines

Measurement lines on the CBN43x.2 cable measurement channels

On the opposite side of the measurement channel housing there are identical cable harnesses on each measurement channel for connecting the temperature sensors (labeled on top cable with "8" in Fig. 2-1 on page 14).

Each measurement channel is assigned an ES411.1 measurement channel and is attached to connectors following the same design as a 4-wire platinum temperature sensor.

Measurement lines with direct connection to the ES411.1 (CBN431.2, CBN433.2)

Two identical cable harnesses are located on the Souriau plug for directly connecting sensors with analog output signals to the ES411.1 module (labeled "8" on bottom cable in Fig. 2-1). Each cable harness is assigned an ES411.1 measurement channel and wired following the same design:

- Connections for a (optional) sensor,
- Connections with sensor voltage supply and
- Connections reading out the sensor.

Measurement line contacts

For contacts in the measurement design, the user can optionally shorten or finish the measurement channel cable ends (Open Wire) (see Fig. 2-1 on page 14).

2.2.5 Operating power

The output voltage of the ES411.1 A/D module (module sensor supply voltage) is used as the CBN43x.2 sensor cable voltage supply in this application. Since there is a separate sensor supply connection for each of the ES411.1 A/D module's measurement channels, each of the sensor cable measurement channels have a separate operating power supply.

The cable attached to the sensor connector of the ES411.1 transfers both the sensor supply voltage and the sensor output voltage for each sensor. Additional cables or an additional external power supply device for sensor supply voltage are not necessary.

2.2.6 Cable identification

Functions when using ETAS application software

If the Temperature Sensor Connection Cable ES411.1 module combination is operated with ETAS application software (INCA), the following automatic functions are implemented for each measurement channel:

- Automatic setting of voltage supply for the Temperature Sensor Connection Cable through the ES411.1 A/D module,
- Automatic transfer of individual alignment and calibration values for the combination of Temperature Sensor Connection Cable and ES411.1 module,
- Automatic setting of the measurement range for the Temperature Sensor Connection Cable in INCA
- Conversion of measured resistance values in temperatures
- Temperature display in application program.

These functions are realized individually in each measurement channel through technology using processes according to TEDS standards.

Functionality when using ETAS configuration software and custom client application software

If the combination of Temperature Sensor Connection Cable and ES411.1 module is configured with ETAS configuration software (ES4xx Configuration Tool for stand-alone operations) and if it is operated by custom client application software, the following functions are implemented for each measurement channel:

- Automatic setting of voltage supply for the Temperature Sensor Connection Cable through the ES411.1 A/D module,
- Provision of an A2L file for import into custom client application software with individual alignment and calibration values as well as the necessary measurement range for the combination of Temperature Sensor Connection Cable and ES411.1 module.

With the information from the A2L file, the combination of Temperature Sensor Connection Cable and ES411.1 module can be integrated into custom client application software.

Limitations when using custom client application software

If the Temperature Sensor Connection Cable ES411.1 module combination is used with custom client application software, the product can only be used to a limited degree or with increased effort:

- The ES411.1 module output voltage (module sensor supply voltage) being used as the voltage supply for the Temperature Sensor Connection Cable, must be manually set to 12 V.
- Alignment and calibration for the Temperature Sensor Connection Cable and ES411.1 module combination must be manually entered in the custom client application software by the user for each module.
ETAS will provide these values upon request.
- The information required for automatically setting the measurement range for the Temperature Sensor Connection Cable can only be read out from the ES411.1 module using ETAS application software. Clients using their own application software must therefore manually set the measurement range.
- The conversion of measured resistance values in temperatures and the display of temperatures must occur in the application software used by the client.

2.2.7 Serial number

The Temperature Sensor Connection Cable CBN43x.2 serial number can be found near the Souriau plug on the splitter cable (No. 4 in Fig. 2-1 on page 14). You will need it if contacting ETAS technical customer service.

The CBN43x.2 Temperature Sensor Connection Cable serial number is not used in the application software.

2.3 Wiring

CBN43x.2 Temperature Sensor Connection Cable Souriau plugs are connected directly to the ES411.1 A/D module.

For connecting the CBN43x.2 sensor cable with the platinum temperature sensor, the users can optionally shorten or finish the measurement channel cable ends (see Fig. 2-1 on page 14).

The mechanical construction of the Temperature Sensor Connection Cable CBN43x.2 guarantees short lines between the measurement channel electronics and the temperature sensor connections. Longer connections in the measurement design can be realized with the ES411.1 module Daisy Chain wiring.

3 Technical Data

The chapter "Technical Data" describes the met standards and norms, environmental requirement, system prerequisites for operation of the Temperature Sensor Connection Cable CBN43x.2, electrical and mechanical data, assignment of measurement channels, and the assignment of measurement lines.

Note

Information for the ES411.1 module can be found in the user's guide "ES411.1 A/D Module With Sensor Supply ."

3.1 General data

3.1.1 Met standards and norms

The Temperature Sensor Connection Cable CBN43x.2, connected to the ES411.1 module, meets the following standards and norms:

| Norm | Test |
|--------------|--|
| EN 61010-1 | Safety regulations for electrical measurement, control, monitoring, and laboratory devices |
| EN 61326 | Electrical equipment for measurement, control and laboratory use - EMC requirements |
| EN 61000-6-2 | Interference immunity (industrial environments) ¹⁾ |
| EN 61000-6-4 | Interference emission (industrial environments) |

¹⁾: The module must be supplied by a DC voltage mains adaptor or a battery with operating power. Cables with a maximum length of 30 m are permitted between module and power source.

The Temperature Sensor Connection Cable CBN43x.2 is designed only for use in industrial environments in accordance with EN 61000-6-4. When using the module outside of industrial environments avoid possible radio disturbances by additional shielding measures!



WARNING!

This is a class A product. In a domestic environment this product may cause radio interference in which case the user may be required to take adequate measures.

3.1.2 Type test

The Temperature Sensor Connection Cable CBN43x.2 was type tested and certified by an accredited test lab. Information on product type testing is available from ETAS upon request.

3.1.3 Environmental requirements

| | |
|--------------------------------------|---------------------------------------|
| Operating temperature range | -40 °C to +85 °C -40 °F to +185 °F |
| Altitude | Max. 5000 m/ 16400 ft |
| Relative humidity (non-condensation) | 0 to 95% |
| Protection class | IP65 |

3.1.4 Cleaning the product

We recommend to clean the product with a dry cloth.

3.2 System requirements

3.2.1 Hardware

Note

The CBN43x.2 Temperature Sensor Connection Cable is only intended for use with the ES411.1 A/D module with sensor supply.

ES411.1 module hardware version requirements

For complete support of the Temperature Sensor Connection Cable ES411.1 module combination in the application software, a compatible ES411.1 module hardware version (hardware version) is required.

Note

Before using the Temperature Sensor Connection Cable with the ES411.1 module, check the module hardware version.

A sticker with the module's hardware version is located on the bottom of the module. There is also a possibility to call up the hardware version with the "HSP Update Tool" service software.

| Hardware Version | Note | Functionality with Temperature Sensor Connection Cable |
|------------------|--------------------|--|
| V3.x and newer | Current HW version | Normal functionality |
| V2.x | Updated module | Normal functionality |
| V1.x | Older HW versions | Hardware update required. Please send module to ETAS. |

3.2.2 Power supply

The ES411.1 A/D module with sensor supply supplies the CBN43x.2 Temperature Sensor Connection Cable and the connected sensors with operating power via the Souriau plug. No other cables are necessary. The ES411.1 module (module sensor supply voltage) output voltage is used as a voltage supply for the Temperature Sensor Connection Cable and the connected sensors in this application.

3.2.3 Software

Module ES411.1 firmware requirements

In order for the Temperature Sensor Connection Cable to be supported in ES411.1 modules, the ES411.1 module requires firmware with expanded functionality. This firmware is delivered with the "HSP Update Tool" service software for versions V9.7.0 and higher.

Update your ES411.1 modules with older firmware versions with HSP V9.7.0 or higher.

Application software requirements

To configure as well as control and collect data for the ES411.1 in combination with the CBN43x.2 Temperature Sensor Connection Cable, you need an ES411.1 module with current firmware and software in the following versions:

- INCA V7.0 with INCA AddOn ES4xx V1.3.2 and higher
or
- ES4xx Configuration Tool V1.3.2 and higher from ES4xx_DRV_SW (stand alone operation)
or
- Clients using their own application software not supporting the XCP-on-Ethernet, must supplement this software with a C-based library (C-API) for the integration of XCP-on-Ethernet drivers. The C-based library is available at ETAS.

Note

Operation of the CBN43x.2 Temperature Sensor Connection Cable, connected to the ES411.1 module, is not possible with older software versions.

Limitations when using custom client application software

If the Temperature Sensor Connection Cable ES411.1 module combination is used with custom client application software, the product can only be used to a limited degree or with increased effort. Observe the notes regarding this in chapter 2.2.6 on page 16.

Additional information

Configuration instructions for the ES411.1 A/D module can be found in the corresponding software documentation.

3.3 Electrical data

Note

Insofar as not otherwise indicated, all data apply for 25 °C and for the operation of the CBN43x.2 Temperature Sensor Connection Cable with the ES411.1 module.

| Parameter | Symbol | Conditions | Min. | Type | Max. | Unit |
|---|-------------------|--|------|------|------|------|
| Measurement range | T_{meas} | CBN43x.2 | -50 | | 250 | °C |
| Measurement current | I_{meas} | CBN430.2, CBN431.2 | | 1 | | mA |
| | | CBN432.2, CBN433.2 | | 0.5 | | mA |
| | | CBN434.2 | | 0.2 | | mA |
| Maximum measurement error (CBN43x.2 with ES411.1 module) | | CBN43x.2 | | 0.2 | | K |
| Maximum measurement error (CBN43x.2 with ES411.1 module) | | CBN43x.2, $T_{\text{min}} \leq T_{\text{a}} \leq T_{\text{max}}$, $T_{\text{meas}} = -50 \text{ °C to } +100 \text{ °C}$ | | | 0.75 | K |
| | | CBN43x.2, $T_{\text{min}} \leq T_{\text{a}} \leq T_{\text{max}}$, $T_{\text{meas}} = 100 \text{ °C to } 250 \text{ °C}$ | | | 0.9 | K |
| Noise (effective) | | 4 kHz bandwidth | | 0.01 | | K |
| Response time | | To 99% of the end value | | | | |
| | t_{rise} | CBN430.2, CBN432.2, CBN433.2: -45 °C → +210 °C | | | 60 | ms |
| | t_{fall} | CBN430.2, CBN432.2, CBN433.2: +210 °C → -45 °C | | | 30 | ms |
| | t_{rise} | CBN434.2: -45 °C → +210 °C | | | 100 | ms |
| | t_{fall} | CBN434.2: 210 °C → -45 °C | | | 70 | ms |
| Calibration interval | | Product within specification | 1 | | | Year |

Note

The Temperature Sensor Connection Cable CBN43x.2 is intended for use with temperature sensors according to DIN EN 60751.

3.4 Mechanical data

Note

The Temperature Sensor Connection Cable CBN430.2, CBN432.2 and CBN434.2 are mechanically identical.
The Temperature Sensor Connection Cable CBN431.2 and CBN433.2 are mechanically identical.

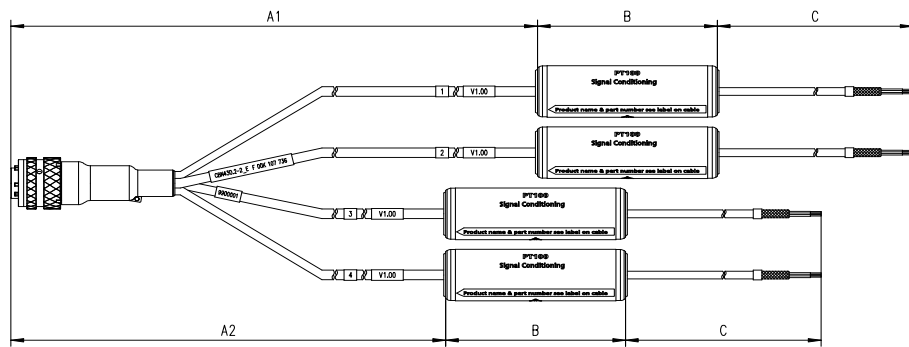

Fig. 3-1 CBN430.2

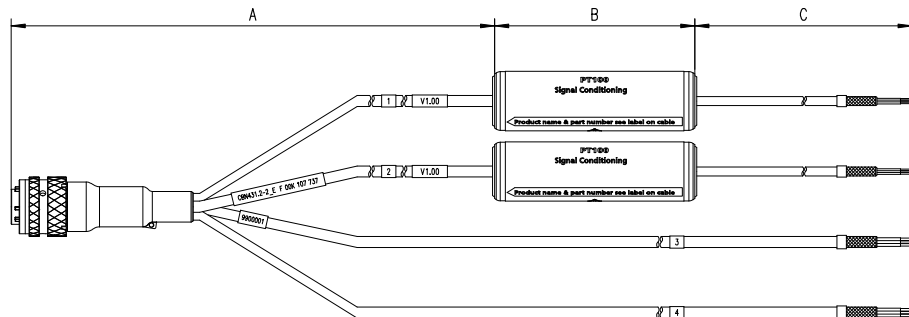

Fig. 3-2 CBN431.2

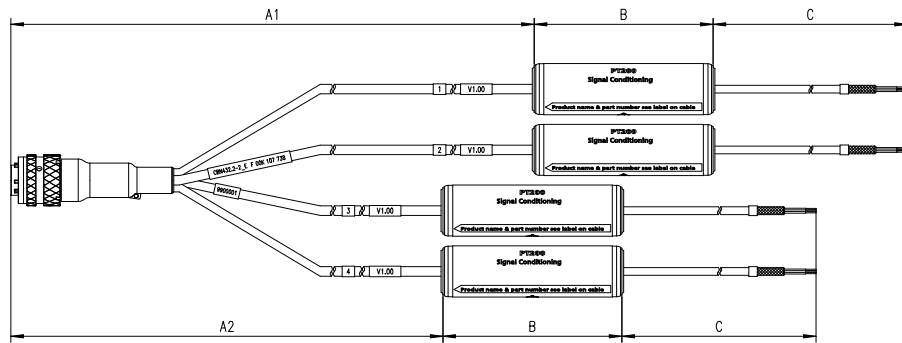

Fig. 3-3 CBN432.2

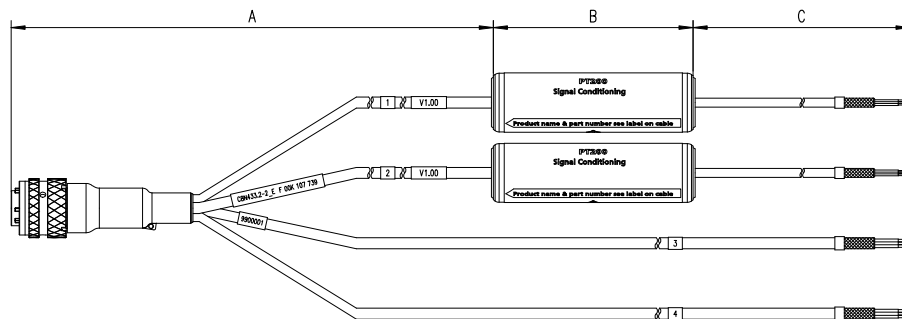

Fig. 3-4 CBN433.2

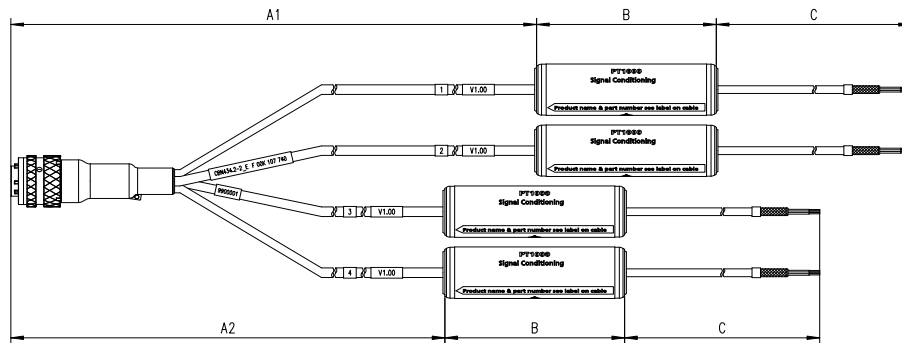

Fig. 3-5 CBN434.2

| | |
|--------------------------------------|--|
| Dimensions (see illustrations above) | A, A1: 1650 mm (straight length; connection to ES411.1) |
| | A, A1: 1650 mm (straight length; connection to ES411.1) |
| | B: 70 mm (diameter: 26 mm) |
| | C: 300 mm (measurement lines) |
| Weight | CBN430.2, CBN432.2, CBN434.2: approx. 435 g |
| | CBN431.2, CBN433.2: approx. 345 g |

3.5 Measurement line assignment

The four Temperature Sensor Connection Cable CBN43x.2 measurement channels are labeled 1 through 4 on the splitter cable on the side with the Souriau plug (see figure in chapter 3.4). The assignment of Temperature Sensor Connection Cable measurement channels to ES411.1 measurement channels is presented in the following table.

| CBN43x.2 Measurement Channel | ES411.1 Measurement Channel |
|-------------------------------------|------------------------------------|
| 1 | 1 |
| 2 | 2 |
| 3 | 3 |
| 4 | 4 |

This channel assignment is used in the application software.

3.6 Assignment of measurement lines

3.6.1 Measurement lines on the CBN43x.2 cable measurement channels

On the opposite side of the measurement channel housing there are identical cable harnesses on each measurement channel for connecting the temperature sensors (labeled on top cable with "8" in Fig. 2-1 on page 14).

The connections between measurement lines to measurement cables of the Temperature Sensor Connection Cables CBN43x.2 are identically assigned:

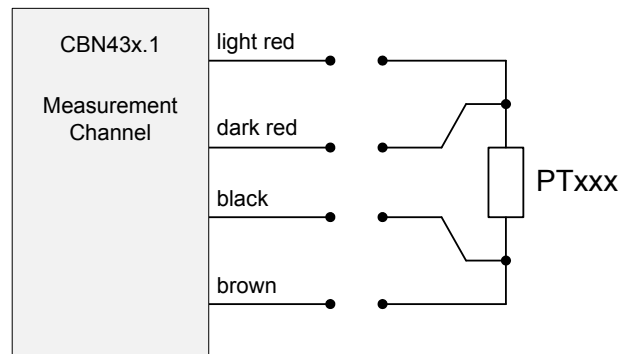

Fig. 3-6 Connection of platinum temperature sensors

| Color | Signal | Meaning |
|--------------|---------------|----------------------------|
| bright red | PT_CUR+ | Measurement current, plus |
| brown | PT_CUR- | Measurement current, minus |
| dark red | PT_SENS+ | Measurement voltage |
| black | PT_SENS- | Measurement voltage |

3.6.2 Measurement lines with direct connection to the ES411.1 (CBN431.2, CBN433.2)

Two identical cable harnesses are located on the Souriau plug for directly connecting sensors with analog output signals to the ES411.1 module (labeled "8" on bottom cable in Fig. 2-1 on page 14).

Both cable harnesses are labeled "3" and "4" and assigned to the measurement channels "3" and "4" in the ES411.1 module.

The measurement line connections to both cable harnesses for the Temperature Sensor Connection Cable CBN431.2 and CBN433.2 are identically assigned. The assignment of connections of the measurement line of a cable harness to the signals of the ES411.1 module is presented in the table:

| Color | Signal | Meaning |
|--------------|---------------|-----------------------------|
| green | In+ | Entry (+) |
| yellow | In- | Entry (-) |
| brown | S+ | Sensor supply voltage (+) |
| pink | SGND | Sensor supply voltage (GND) |
| grey | TEDS+ | TEDS connection (+) *) |
| white | TEDS- | TEDS connection (+) *) |

*) TEDS following IEEE1451.4

4 Ordering Information

4.1 CBN430.2

| Order name | Short name | Order number |
|---|-------------|---------------|
| CBN430.2 PT100 Sensor Connection Cable, 4 Channels, Souriau 8ST12-35 4xOpen Wire, 2 m | CBN430.2-2m | F 00K 107 725 |

Scope of supply

CBN430.2 PT100 Sensor Connection Cable, ETAS Safety Advice, China-RoHS-leaflet_Compact_green_cn, Calibration-Certification

4.2 CBN431.2

| Order name | Short name | Order number |
|---|-------------|---------------|
| CBN431.2 PT100 Sensor Connection Cable, 2 PT100 Channels + 2 Analog Input Channels, Souriau 8ST12-35 4xOpen Wire, 2 m | CBN431.2-2m | F 00K 107 726 |

Scope of supply

CBN431.2 PT100 Sensor Connection Cable, 2 PT100 Channels + 2 Analog Input Channels, ETAS Safety Advice, China-RoHS-leaflet_Compact_green_cn, Calibration-Certification

4.3 CBN432.2

| Order name | Short name | Order number |
|---|-------------|---------------|
| CBN432.2 PT200 Sensor Connection Cable, 4 Channels, Souriau 8ST12-35 4xOpen Wire, 2 m | CBN432.2-2m | F 00K 107 361 |

Scope of supply

CBN432.2 Current Probe (Molex), ETAS Safety Advice, China-RoHS-leaflet_Compact_green_cn, Calibration-Certification

4.4 CBN433.2

| Order name | Short name | Order number |
|--|-------------|---------------|
| CBN433.2 PT200 Sensor Connection Cable, 2 PT200 Channels + 2 Analog Input Channels, Souriau 8ST12-35 4xOpen Wire, 2 m | CBN433.2-2m | F 00K 107 727 |
| Scope of supply | | |
| CBN433.2 PT200 Sensor Connection Cable, 2 PT200 Channels + 2 Analog Input Channels, ETAS Safety Advice, China-RoHS-leaflet_Compact_green_cn, Calibration-Certification | | |

4.5 CBN434.2

| Order name | Short name | Order number |
|---|-------------|---------------|
| CBN434.2 PT1000 Sensor Connection Cable, 4 Channels, Souriau 8ST12-35 4xOpen Wire, 2 m | CBN434.2-2m | F 00K 107 729 |
| Scope of supply | | |
| CBN434.2 PT1000 Sensor Connection Cable, 4 Channels, ETAS Safety Advice, China-RoHS-leaflet_Compact_green_cn, Calibration-Certification | | |

4.6 Calibration Service

| Order name | Short name | Order number |
|----------------------------------|------------|---------------|
| Calibration Service for CBN430.2 | K_CBN430 | F 00K 107 945 |
| Calibration Service for CBN431.2 | K_CBN431 | F 00K 107 946 |
| Calibration Service for CBN432.2 | K_CBN432 | F 00K 107 947 |
| Calibration Service for CBN433.2 | K_CBN433 | F 00K 107 948 |
| Calibration Service for CBN434.2 | K_CBN434 | F 00K 107 949 |

5 **ETAS Contact Addresses**

ETAS HQ

ETAS GmbH

Borsigstraße 14

70469 Stuttgart

Germany

Phone: +49 711 3423-0

Fax: +49 711 3423-2106

WWW: www.etas.com

ETAS Subsidiaries and Technical Support

For details of your local sales office as well as your local technical support team and product hotlines, take a look at the ETAS website:

ETAS subsidiaries WWW: www.etas.com/en/contact.php

ETAS technical support WWW: www.etas.com/en/hotlines.php

Figures

| | | |
|-----------------|---|----|
| Fig. 1-1 | WEEE symbol..... | 7 |
| Fig. 2-1 | Diagram of the CBN430.2/ CBN432.2/ CBN434.2 (top) and CBN431.2/ CBN433.2 (bottom) sensor cable | 14 |
| Fig. 3-1 | CBN430.2..... | 23 |
| Fig. 3-2 | CBN431.2..... | 23 |
| Fig. 3-3 | CBN432.2..... | 24 |
| Fig. 3-4 | CBN433.2..... | 24 |
| Fig. 3-5 | CBN434.2..... | 24 |
| Fig. 3-6 | Connection of platinum temperature sensors..... | 25 |

Index

A

Accident prevention 5
Ambient temperature 20
Application software 21

C

Cable identification 16
CE conformity declaration 6
Channel assignment, application software 25
Cleaning 6
Configuration instructions 21
Customer service 17

D

Data
 mechanical 23
 technical 19
Documentation 5

E

Electrical data 22
ES411.1 A/D module 12
ETAS Contact Addresses 29
ETAS measurement system 12

F

Firmware 21

H

Hardware version, compatible 20
Hardware version, sticker 20
Hardware, system requirements 20
Housing 15

M

Measurement channels 15
Measurement channels, assignment of 25
Measurement lines 15
Measurement lines, labeling 25
Mechanical data 23

O

Operating power 16
Operation
 Conventions 8
Operation, requirements for 6

P

Power supply 21
Product return 7
Properties 12

Q

Qualification, required 5

R

Recycling 7

RoHS conformity
 China 6
 European Union 6

S

Safety at work 5
Safety instructions, basic 5
Safety instructions, labeling 5
Safety precautions 5
Scope of delivery 8
Serial number 17
Signal conditioning 15
Souriau plug 15, 25, 26
Splitter cable 15
Standards and norms 19
Structure 8
System requirements 20

T

Technical data 19
Test lab, accredited 13, 19
Type testing, information on 19

U

Use, correct 5

W

Waste Electrical and Electronic Equip-
 ment - WEEE 7
WEEE return system 7
Wiring 17