

**CBN420.2/ CBN421.2/ CBN422.2**  
**Sensor cable providing bipolar sensor supply**  
User's Guide



## Copyright

---

The data in this document may not be altered or amended without special notification from ETAS GmbH. ETAS GmbH undertakes no further obligation in relation to this document. The software described in it can only be used if the customer is in possession of a general license agreement or single license. Using and copying is only allowed in concurrence with the specifications stipulated in the contract.

Under no circumstances may any part of this document be copied, reproduced, transmitted, stored in a retrieval system or translated into another language without the express written permission of ETAS GmbH.

© **Copyright 2016** ETAS GmbH, Stuttgart

The names and designations used in this document are trademarks or brands belonging to the respective owners.

CBN42x.2 - User's Guide R07 EN - 02.2016

---

## Contents

<b>1</b>	General	5
<b>1.1</b>	Basic Safety Instructions	5
<b>1.1.1</b>	Labeling of Safety Instructions	5
<b>1.1.2</b>	General safety information	5
<b>1.1.3</b>	Requirements for users and duties for operators	5
<b>1.1.4</b>	Correct Use	5
<b>1.2</b>	RoHS conformity	6
<b>1.2.1</b>	European Union	6
<b>1.2.2</b>	China	6
<b>1.3</b>	CE labeling	6
<b>1.4</b>	Product return and recycling	7
<b>1.5</b>	Product labeling	7
<b>1.6</b>	About this manual	8
<b>1.6.1</b>	Structure	8
<b>1.6.2</b>	Using the manual	8
<b>1.7</b>	Scope of delivery	8
<b>1.8</b>	Additional information	9
<b>2</b>	Hardware Description	11
<b>2.1</b>	Overview	11
<b>2.1.1</b>	Field of application and product variants	11
<b>2.1.2</b>	Combined use with the ES411.1 A/D module	12
<b>2.1.3</b>	Properties	12
<b>2.2</b>	Assembly and functionality	14
<b>2.2.1</b>	Diagram of Sensor cable providing bipolar sensor supply	14
<b>2.2.2</b>	Splitter cable	15
<b>2.2.3</b>	Measurement channels	15
<b>2.2.4</b>	Measurement lines	15
<b>2.2.5</b>	Operating power	15

<b>2.2.6</b>	Serial number .....	16
<b>2.3</b>	Wiring .....	16
<b>2.4</b>	Configuration .....	16
<b>3</b>	Technical Data .....	17
<b>3.1</b>	General data .....	17
<b>3.1.1</b>	Met standards and norms .....	17
<b>3.1.2</b>	Type test .....	17
<b>3.1.3</b>	Environmental requirements .....	18
<b>3.1.4</b>	Cleaning the product .....	18
<b>3.2</b>	System requirements .....	18
<b>3.2.1</b>	Hardware .....	18
<b>3.2.2</b>	Power supply .....	18
<b>3.3</b>	Electrical data .....	18
<b>3.4</b>	Mechanical data .....	20
<b>3.5</b>	Assignment of measurement channels .....	21
<b>3.6</b>	Assignment of measurement connections .....	22
<b>3.6.1</b>	CBN420.2 .....	22
<b>3.6.2</b>	CBN421.2 .....	22
<b>3.6.3</b>	CBN422.2 .....	23
<b>4</b>	Ordering Information .....	25
<b>4.1</b>	CBN420.2 .....	25
<b>4.2</b>	CBN421.2 .....	25
<b>4.3</b>	CBN422.2 .....	25
<b>5</b>	ETAS Contact Addresses .....	27
	Figures .....	29
	Index .....	31

## 1 General

---

The introductory chapter informs you about the basic safety information, product return and recycling, the use of this manual, the scope of delivery and other information.

### 1.1 Basic Safety Instructions

---

#### 1.1.1 Labeling of Safety Instructions

---

The safety instructions contained in this manual are shown with the standard danger symbol shown below:



The following safety instructions are used. They provide extremely important information. Please read this information carefully.



#### **CAUTION!**

*indicates a low-risk danger which could result in minor or less serious injury or damage if not avoided.*

#### 1.1.2 General safety information

---

Please observe the product safety advice ("ETAS Safety Advice") and the subsequent safety instructions to avoid any impact on your health or damages to the device.

#### **Note**

*Carefully read the documentation that belongs to the product prior to the startup.*

ETAS GmbH does not assume any liability for damages resulting from improper handling, unintended use or non-observance of the safety precautions.

#### 1.1.3 Requirements for users and duties for operators

---

The product may be assembled, operated and maintained only if you have the necessary qualification and experience for this product. Improper use or use by a user without sufficient qualification can lead to damages or injuries to one's health or damages to property.

#### *General safety at work*

---

The existing regulations for safety at work and accident prevention must be followed.

#### 1.1.4 Correct Use

---

This product has been developed and released for use in automotive applications. For usage in other domains please contact your ETAS representative.

### *Requirements for Operation*

---

The following requirements are necessary for safe operation:

- Prior to assembly and operation, observe the notes for environmental requirements (see chapter 3.1.3 on page 18).
- Ensure compliance with the connected and settings values (see chapter 3.2.2 on page 18).

**WARNING!**

*This is a class A product. In a domestic environment this product may cause radio interference in which case the user may be required to take adequate measures.*

### *Requirements for the technical State of the Product*

---

The product is designed in accordance with state-of-the-art technology and recognized safety rules. The product may be operated only in a technically flawless condition and according to the intended purpose and with regard to safety and dangers as stated in the respective product documentation. If the product is not used according to its intended purpose, the protection of the product may be impaired.

### *Maintenance and cleaning*

---

The product is maintenance-free. For cleaning, use a clean and dry cloth.

## 1.2 RoHS conformity

### 1.2.1 European Union

The EU Directive 2002/95/EU limits the use of certain dangerous materials for electrical and electronic devices (RoHS conformity).

ETAS confirms that the product corresponds to this directive which is applicable in the European Union.

### 1.2.2 China

ETAS confirms that the product meets the product-specific applicable guidelines of the China RoHS (Management Methods for Controlling Pollution Caused by Electronic Information Products Regulation) applicable in China with the China RoHS marking affixed to the product or its packaging.

## 1.3 CE labeling

ETAS confirms that the product meets the product-specific, applicable European guideline with a CE label on the product or its packaging. CE conformity declaration for the product is available upon request.

### 1.4 Product return and recycling

The European Union (EU) issued the Waste Electrical and Electronic Equipment (WEEE) Directive to ensure the setup of systems for collecting, handling and processing electronic waste in all countries of the EU.

This ensures that the equipment is recycled in a resource-saving manner that does not represent any risk for the health and safety of humans and the environment.



**Fig. 1-1** WEEE symbol

The WEEE symbol (see Fig. 1-1 on page 7) on the product or its packaging indicates that the product may not be disposed of with regular trash.





The user is obligated to separate the waste equipment and to provide it to the WEEE return system for reuse.

The WEEE guidelines apply to all ETAS devices, but not external cables or batteries.

Additional information on the ETAS GmbH recycling program is available from the ETAS sales and service department (see chapter 5 on page 27).

### 1.5 Product labeling

The following symbols are used for product labeling:

Symbol	Description
	Prior to operating the product, be sure to read the user's guide!
	Labeling for RoHS (EU), see chapter 1.2.1 on page 6
	Labeling for CE conformity, see chapter 1.3 on page 6
	Labeling for RoHS (China), see chapter 1.2.2 on page 6

Please observe the information in chapter "Technical Data" on page 17.

## 1.6 About this manual

---

This manual describes the operational and technical data for the Sensor cable providing bipolar sensor supply CBN42x.2.

### 1.6.1 Structure

---

This manual consists of four chapters and an index.

- **Chapter 1: "Introduction"**

The "Introduction" chapter (this chapter) provides you with information on basic safety notices, product return and recycling, how to use this manual, notes on the scope of delivery, and additional information.

- **Chapter 2: "Hardware Description"**

In the "Hardware Description" chapter you'll find an overview of product variants for the Sensor cable providing bipolar sensor supply CBN42x.2, information on combined implementation with the ES411.1 A/D module, the housing, connections, measurement channels, power supply, cable identification, serial number, as well as wiring.

- **Chapter 3: "Technical Data"**

The "Technical Data" chapter describes the standards and norms met, the environmental requirements, system prerequisites for operation of the Sensor cable providing bipolar sensor supply CBN42x.2, electrical and mechanical data, assignment of measurement channels, and measurement line labeling.

- **Chapter 4: "Ordering Information"**

In the "Ordering Information" chapter you'll find information for ordering the Sensor cable providing bipolar sensor supply.

The concluding chapter "ETAS Contacts" provides you with information on international ETAS sales and service offices.

### 1.6.2 Using the manual

---

#### *Typographical conventions*

---

The following typographical conventions are used:

<b>Bold</b>	Device labeling
<i>Italics</i>	Particularly important sections

Important notes for the user are displayed as follows:

**Note**

*Important note for user.*

## 1.7 Scope of delivery

---

Before initial operation of your CBN42x.2, please verify that the device was delivered with all necessary parts (see chapter 4 on page 25).



## 1.8 Additional information

The configuration instructions for the Sensor cable providing bipolar sensor supply CBN42x.2 under INCA can be found in the corresponding software documentation.



## 2 Hardware Description

In the "Hardware Description" chapter you'll find an overview of product variants for the Sensor cable providing bipolar sensor supply CBN42x.2, information on combined implementation with the ES411.1 A/D module, housing, connections, measurement channels, power supply, serial number, wiring, as well as configuration notes.

### 2.1 Overview

#### 2.1.1 Field of application and product variants

The growing number of electric loads with higher power consumption in vehicle power circuit boards (turn signals, seat and windshield heating, seat adjustment, interior heating, etc.) require measurement and monitoring of high operational currents in development. In hybrid and electric vehicles, high currents must be measured potential-free in high voltage areas.

If transformers are used for these current measurements, neither a measurement resistor in the measurement circuit nor an electrical connection to the measurement circuit are required. Some transformer types are based on a magnetic current measurement technology, are galvanically isolated, and guarantee safe operation in high-voltage areas. These transformers deliver a highly exact output voltage and require a bipolar voltage supply for operation depending on type.

The Sensor cable providing bipolar sensor supply CBN42x.2 was designed for connection to the transformer or other sensors with bipolar supply voltage. They are offered in three electrically identical variants with different sensor connections:

Sensor cable providing bipolar sensor supply	Sensor Connection
CBN420.2	Lemo 1B PHG
CBN421.2	Open wire
CBN422.2	Molex 51191

#### **Note**

*Description, properties, and technical data in this manual apply to all variants of the Sensor cable providing bipolar sensor supply (CBN420.2, CBN421.2, and CBN422.2), insofar as not otherwise noted.*

*The shared abbreviation "CBN42x.2" is used in these text components.*

#### **Note**

*The three variants of the Sensor cable providing bipolar sensor supply CBN42x.2 are electrically identical and, with the exception of the sensor connection, mechanically identical.*

#### **Note**

*The Sensor cable providing bipolar sensor supply CBN42x.2 are intended for use with LEM (HTR series) transformers or comparable transformers as well as with other sensors with bipolar supply voltage whose measure circuit is galvanically isolated from the output (see chapter3.3 on page 18).*

### 2.1.2 Combined use with the ES411.1 A/D module

---

The Sensor cable providing bipolar sensor supply CBN42x.2 consist of four identical active electrical measurement channels integrated into a splitter cable and intended for combined use with the ES411.1 A/D module.

Combination with the Sensor cable providing bipolar sensor supply expands the four ES411.1 module channels for potential-free measurement of higher currents, for example, in the vehicle systems on-board power supply.

#### *ES411.1 Module functionality*

---

The ES411.1 module assumes the following functions when used in combination with the CBN42x.2 sensor cable:

- CBN42x.2 sensor cable power supply,
- Power supply for connected transformers or other sensors,
- A/D conversion of measurement values
- Time-synced transfer of the measurement values to a PC or the application program.

#### *Galvanic Isolation*

---

The galvanic isolation of the measurement circuit and the ES411.1 module occurs in the transformers connected to the sensor cable.

#### *Integration into the ETAS measurement system*

---

The integration of the Sensor cable providing bipolar sensor supply CBN42x.2 into the ETAS measurement system and into INCA provides an efficient solution for collecting currents when developing, applying, and validating electronic control of electric drives and loads with high power consumptions.

### 2.1.3 Properties

---

The most important properties of the CBN42x.2 sensor cable with bipolar sensor supply combined with the ES411.1 module:

- Use in combination with the ES411.1 A/D module
- Compact measurement probes for collecting currents in vehicles
- High safety due to galvanized isolation near measurement point
- Electrically identical product variants with different sensor connections:
  - Lemo 1B PHG (CBN420.2)
  - Open wire (CBN421.2)
  - Molex 51191 (CBN422.2)
- Supply voltage to measurement channels integrated into the measurement cable
- Supply voltage of connected transformers integrated into the measurement cable
- Synchronized collection of control unit signals and other measurement data from the vehicle environment
- Automotive serviceable product suited for use in development environments and in vehicles on test tracks.

- Adaptable to environmental conditions (temperature, EMC)
- High mechanical stability and robustness
- Product safety during type testing and certification by an accredited test lab
- together with the ES411.1 module part of the ETAS Tool Suite

Complete technical data for the Sensor cable providing bipolar sensor supply CBN42x.2 can be found in chapter "Technical Data" on page 17.

## 2.2 Assembly and functionality

### 2.2.1 Diagram of Sensor cable providing bipolar sensor supply

**Note**

The three variants of the Sensor cable providing bipolar sensor supply CBN42x.2 are electrically identical and, with the exception of the sensor connection, mechanically identical.

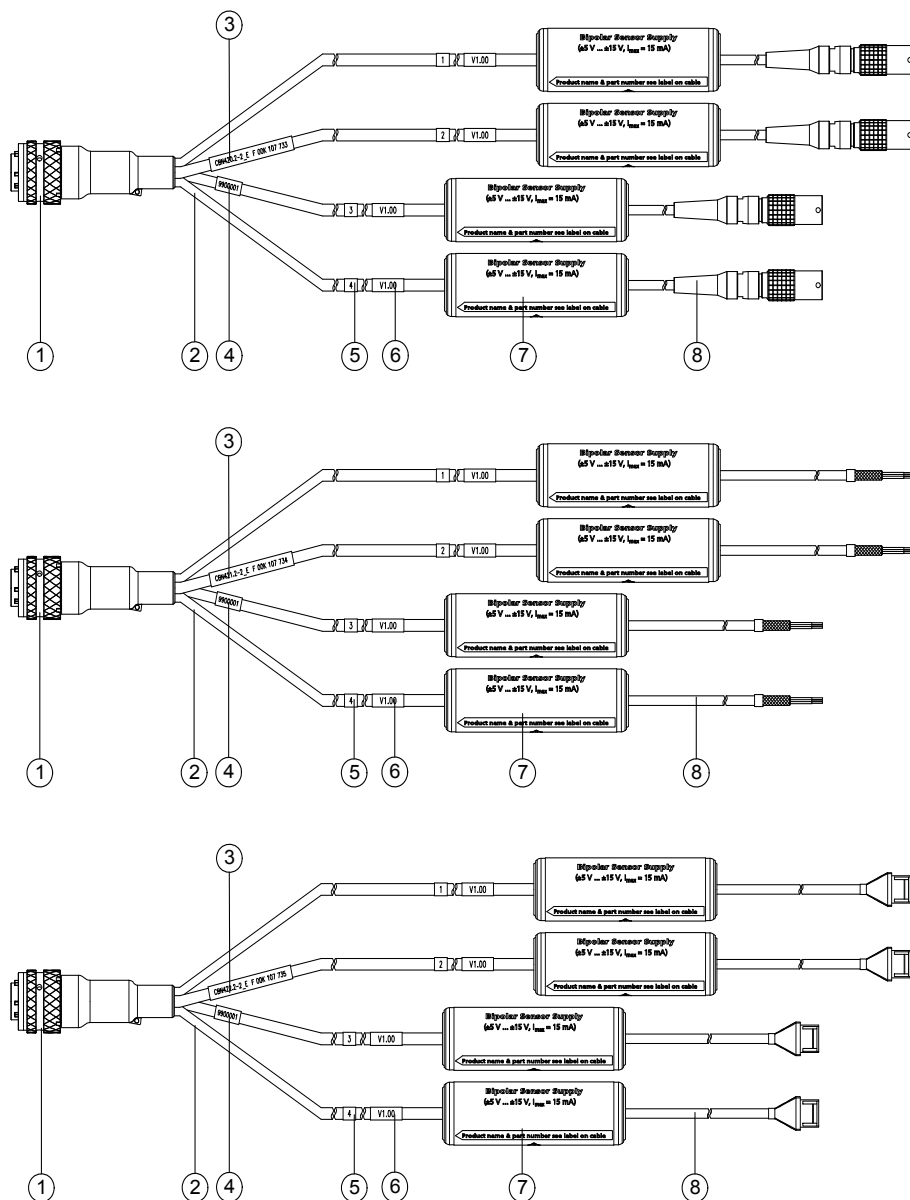

**Fig. 2-1** CBN420.2 Sensor cable diagram (top, Lemo connection), CBN421.2 (middle, Open Wire), and CBN422.2 (bottom, Molex connection)

No. in Fig. 2-1	Designation
1	Souriau plug
2	Splitter cable
3	Product short name and type-parts number
4	Product serial number
5	Measurement channel number
6	Measurement channel hardware version number
7	Measurement channel housing
8	Measurement lines: CBN420.2: Lemo PHG CBN421.2: Open Wire CBN422.2: Molex 51191

### 2.2.2 Splitter cable

---

The Sensor cable providing bipolar sensor supply CBN42x.2 has a splitter cable on a Souriau plug (left) that is connected to four identical measurement channel housings (middle).

### 2.2.3 Measurement channels

---

Each of the four measurement channels are sealed in a separate cylindrical housing containing the measurement channel electronics (see Fig. 2-1 on page 14).

The signal conditioning of input signals and preparations of bipolar supply voltage of the transformer connected to this measurement channel is carried out in the measurement channels.

The four Sensor cable providing bipolar sensor supply CBN42x.2 measurement channels are identical.

### 2.2.4 Measurement lines

---

On the opposite side of the measurement channel housing there are two measurement lines (right) on each measurement channel, which are completed with or without a plug depending on product variant.

### 2.2.5 Operating power

---

The output voltage of the ES411.1 A/D module (module sensor supply voltage) is used as the CBN42x.2 sensor cable voltage supply in this application. The supply is carried over the Souriau plug and no additional cables are necessary.

Since every ES411.1 A/D module measurement channel has its own sensor supply connection, each of the four CBN42x.2 measurement channels are supplied separately with operating power.

In each sensor cable measurement channel a power inverter produces an additional negative output voltage from the related positive output voltage of the ES411.1 module. The bipolar voltage is symmetrical and corresponds to the unipolar output voltage values of the ES411.1 module.

The bipolar voltage for supplying the connected transformer must be configured according to transformer technical data.

For combined operation of the ES411.1 A/D module with the CBN42x.2 sensor cables and transformers no additional power supply is necessary for sensor cables and transformers.

#### 2.2.6 Serial number

---

The Sensor cable providing bipolar sensor supply CBN42x.2 serial number can be found near the Souriau plug on the splitter cable (No. 4 in Fig. 2-1 on page 14). You will need it if contacting ETAS technical customer service.

The CBN42x.2 Sensor cable providing bipolar sensor supply serial number is not used in the application software.

### 2.3 Wiring

---

CBN42x.2 Sensor cable providing bipolar sensor supply Souriau plugs are connected directly to the ES411.1 A/D module.

The CBN420.2 and CBN422.2 sensor cables can be connected directly to the transformer with Lemo or Molex connectors.

To connect the CBN421.2 sensor cable with the transformer, the user can optionally shorten or finish the measurement channel cable ends (see Fig. 2-1 on page 14). The cable ends are not tin-coated, so connectors can be crimped on the cables.

The mechanical construction of the Sensor cable providing bipolar sensor supply CBN42x.2 guarantees short lines between the measurement channel electronics and the transformer connections. Longer connections in the measurement design can be realized with the ES411.1 module Daisy Chain wiring.

### 2.4 Configuration

---

If the combination of Sensor cable providing bipolar sensor supply and ES411.1 module is operated with ETAS application software (INCA), with ETAS configuration software (ES4xx Configuration Tool for stand-alone operation), or with custom client application software, the following parameters must be configured following the technical data of the transformer being used:

- The ES411.1 module (module sensor supply voltage) output voltage being used as the Sensor cable providing bipolar sensor supply voltage supply or transformer, must be manually set to the transformer operating power value in the application software.
- The measurement range must be manually selected in the application software following the measurement range of the connected transformer.



### 3 Technical Data

The chapter "Technical Data" describes the met standards and norms, environmental requirement, system prerequisites for operation of the Sensor cable providing bipolar sensor supply CBN42x.2, electrical and mechanical data, assignment of measurement channels, and the assignment of measurement lines.

#### Note

*Information for the ES411.1 module can be found in the user's guide "ES411.1 A/D Module with Sensor Supply."*

#### 3.1 General data

##### 3.1.1 Met standards and norms

The Sensor cable providing bipolar sensor supply CBN42x.2, connected to the ES411.1 module, meets the following standards and norms:

Norm	Test
EN 61010-1	Safety regulations for electrical measurement, control, monitoring, and laboratory devices
EN 61326	Electrical equipment for measurement, control and laboratory use - EMC requirements
EN 61000-6-2	Interference immunity (industrial environments) <sup>1)</sup>
EN 61000-6-4	Interference emission (industrial environments)

<sup>1)</sup>: The module must be supplied by a DC voltage mains adaptor or a battery with operating power. Cables with a maximum length of 30 m are permitted between module and power source.

The Sensor cable providing bipolar sensor supply CBN42x.2 is designed only for use in industrial environments in accordance with EN 61000-6-4. When using the module outside of industrial environments avoid possible radio disturbances by additional shielding measures!



#### WARNING!

*This is a class A product. In a domestic environment this product may cause radio interference in which case the user may be required to take adequate measures.*

##### 3.1.2 Type test

The Sensor cable providing bipolar sensor supply CBN42x.2 was type tested and certified by an accredited test lab. Information on product type testing is available from ETAS upon request.

3.1.3 Environmental requirements

Operating temperature range	-40 °C to +85 °C -40 °F to +185 °F
Altitude	Max. 5000 m/ 16400 ft
Relative humidity (non-condensation)	0 to 95%
Protection class	IP65

3.1.4 Cleaning the product

We recommend to clean the product with a dry cloth.

3.2 System requirements

3.2.1 Hardware

**Note**

*The CBN42x.2 Sensor cable providing bipolar sensor supply is only intended for use with the ES411.1 A/D module with sensor supply.*

*Additional information*

Configuration instructions for the ES411.1 A/D module can be found in the corresponding software documentation.

3.2.2 Power supply

The output voltage of the ES411.1 A/D module (module sensor supply voltage) is used as the CBN42x.2 sensor cable voltage supply in this application. The supply is carried over the Souriau plug and no additional cables are necessary.

With the bipolar output voltage of the CBN42x.2 sensor cable, the connected transformers or other sensors are supplied with bipolar operating power.

3.3 Electrical data

**Note**

*Insofar as not otherwise indicated, all data apply for 25 °C and for the operation of the CBN42x.2 Sensor cable providing bipolar sensor supply with the ES411.1 module.*

**Note**

*The Sensor cable providing bipolar sensor supply CBN42x.2 are intended for use with LEM (HTR series) transformers or comparable transformers as well as with other sensors with bipolar supply voltage whose measure circuit is galvanically isolated from the output (see chapter 3.3 on page 18).*

Parameter	Symbol	Note	Min.	Type	Max.	Unit
Output voltage	$U_{OUT+}$	Corresponds to the sensor output voltage of the ES411.1 module	+5		+15	V
	$U_{OUT-}$	Generated by the CBN42x.2 sensor cable	-5		-15	V
Output impedance	$R_{OUT}$	$U_{IN} = 5\text{ V to }15\text{ V}$ , $U_{out+} = 5\text{ V to }15\text{ V}$		4		$\Omega$
		$U_{IN} = 5\text{ V}$ , $U_{OUT-} = -5\text{ V}$		100		$\Omega$
		$U_{IN} = 12\text{ V}$ , $U_{OUT-} = -12\text{ V}$		70		$\Omega$
		$U_{IN} = 15\text{ V}$ , $U_{OUT-} = -15\text{ V}$		60		$\Omega$
Output current	$I_{OUT}$	Symmetrical load			15	mA
		$V_{OUT+}$ with load, $V_{OUT-}$ without load		30		mA
		$V_{OUT-}$ with load, $V_{OUT+}$ without load		-25		mA
Isolating voltage	$U_{iso}$	AIN+, AIN-, OUT+, OUT- to power supply of the ES411.1 module				
Short-circuit strength (current limited by ES411.1)		OUT+ to GND, OUT- to GND, OUT+ to OUT-		no electrical isolation		
Ripple and noise (effective)		to OUT-		2.5		mV
Measurement input voltage	$U_{AIN}$	Corresponds to the sensor input voltage of the ES411.1 module		$\pm 10$		V

The Sensor cable providing bipolar sensor supply CBN42x.2 was designed to supply transformers from LEM's HTR series. Typical use consists of 17 mA /-4 mA at  $\pm 15\text{ V}$ . Additional information on the measurement range, isolation voltage, and transformer bandwidth can be found on the product data sheet.

### 3.4 Mechanical data

**Note**

The Sensor cable providing bipolar sensor supply CBN420.2, CBN421.2, and the CBN422.2 are mechanically identical. Dimensions and weight of these Sensor cable providing bipolar sensor supply are identical.

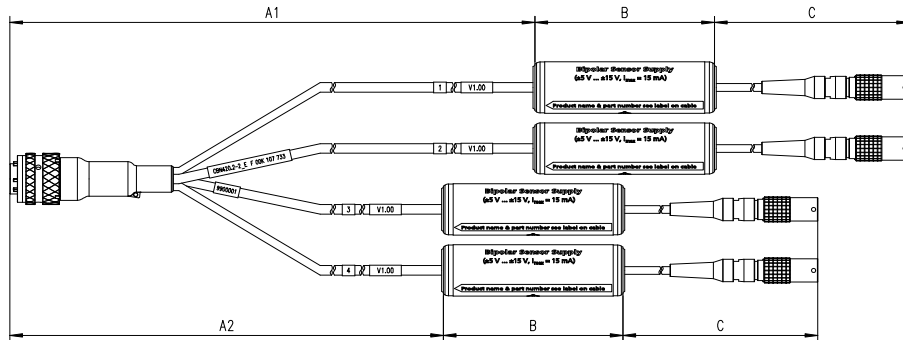

Fig. 3-1 CBN420.2

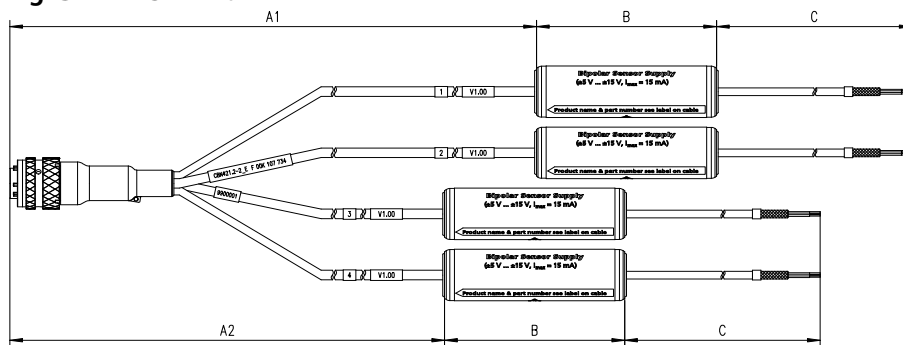

Fig. 3-2 CBN421.2

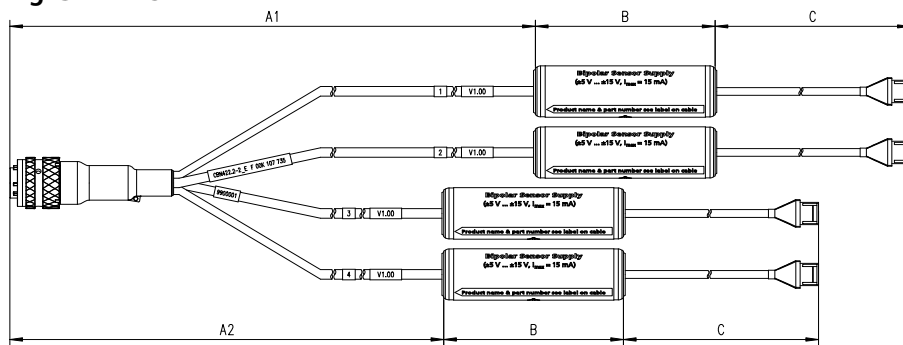

Fig. 3-3 CBN422.2

Dimensions (see illustrations above)	A, A1: 1615 mm (straight length; connection to ES411.1)
	A2: 1415 mm (straight length; connection to ES411.1)
	B: 85 mm (diameter: 25 mm)
	C: 300 mm (measurement lines)
Weight	CBN420.2: approx. 535 g
	CBN421.2: approx. 455 g
	CBN422.2: approx. 475 g

### 3.5 Assignment of measurement channels

The four identical active electrical measurement channels of the Sensor cable providing bipolar sensor supply CBN42x.2 are labeled 1 through 4 on the Souriau plug side of the splitter cable (see figure in chapter 3.4). The assignment of Sensor cable providing bipolar sensor supply measurement channels to ES411.1 measurement channels is presented in the following table.

<b>CBN42x.2 Measurement Channel</b>	<b>ES411.1 Measurement Channel</b>
1	1
2	2
3	3
4	4

This channel assignment is used in the application software.

### 3.6 Assignment of measurement connections

#### 3.6.1 CBN420.2

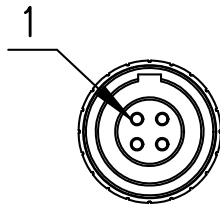

**Fig. 3-4** Lemo PHG.1B.304.CLLD

The connections of the four CBN420.2 sensor cable measurement channels are assigned identically:

Pin	Signal	Note
1	OUT+	Sensor supply voltage, plus
2	OUT-	Sensor supply voltage, minus
3	AIN+	Sensor output voltage
4	AIN-	Sensor output voltage

Connection AIN- (pin 4) is also the sensor supply ground (GND). Within the CBN42x.2 sensor cable, AIN- is connected to SGND of the corresponding sensor channel of the ES411.1 module and thereby also to the ES411.1 power supply ground.

#### 3.6.2 CBN421.2

The connections of the four CBN421.2 sensor cable measurement channels (Open Wire) are assigned identically. The measurement lines are labeled with colors:

Color	Signal	Note
bright red	OUT+	Sensor supply voltage, plus
brown	OUT-	Sensor supply voltage, minus
dark red	AIN+	Sensor output voltage
black	AIN-	Sensor output voltage

Connection AIN- (pin 4) is also the sensor supply ground (GND). Within the CBN42x.2 sensor cable, AIN- is connected to SGND of the corresponding sensor channel of the ES411.1 module and thereby also to the ES411.1 power supply ground.

## 3.6.3 CBN422.2

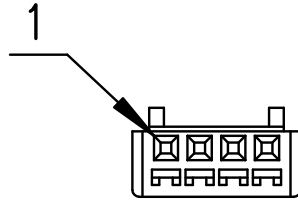

**Fig. 3-5** Molex 51191-004

The connections of the four CBN422.2 sensor cable measurement channels are assigned identically:

Pin	Signal	Note
1	OUT+	Sensor supply voltage, plus
2	OUT-	Sensor supply voltage, minus
3	AIN+	Sensor output voltage
4	AIN-	Sensor output voltage

Connection AIN- (pin 4) is also the sensor supply ground (GND). Within the CBN42x.2 sensor cable, AIN- is connected to SGND of the corresponding sensor channel of the ES411.1 module and thereby also to the ES411.1 power supply ground.





## 4 Ordering Information

---

### 4.1 CBN420.2

---

Order name	Short name	Order number
CBN420.2 Sensor supply conditioning cable providing bipolar sensor supply voltage, 4 Channel, Souriau 4xLemo PHG.1B.304.CLLD, 2m	CBN420.2-2m	F 00K 107 564

#### Scope of supply

CBN420.2 Sensor supply conditioning cable (Lemo), ETAS Safety Advice, China-RoHS-leaflet\_Compact\_green\_cn

### 4.2 CBN421.2

---

Order name	Short name	Order number
CBN421.2 Sensor supply conditioning cable providing bipolar sensor supply voltage, 4 Channel, Souriau 4xopen wire, 2m	CBN421.2-2m	F 00K 107 565

#### Scope of supply

CBN421.2 Current Probe (open wire), ETAS Safety Advice, China-RoHS-leaflet\_Compact\_green\_cn

### 4.3 CBN422.2

---

Order name	Short name	Order number
CBN422.2 Sensor supply conditioning cable providing bipolar sensor supply voltage, 4 Channel, Souriau 4xMolex 51191-004, 2m	CBN422.2-2m	F 00K 107 566

#### Scope of supply

CBN422.2 Current Probe (Molex), ETAS Safety Advice, China-RoHS-leaflet\_Compact\_green\_cn



## 5 **ETAS Contact Addresses**

---

### *ETAS HQ*

---

ETAS GmbH

Borsigstraße 14

70469 Stuttgart

Germany

Phone: +49 711 3423-0

Fax: +49 711 3423-2106

WWW: [www.etas.com](http://www.etas.com)

### *ETAS Subsidiaries and Technical Support*

---

For details of your local sales office as well as your local technical support team and product hotlines, take a look at the ETAS website:

ETAS subsidiaries WWW: [www.etas.com/en/contact.php](http://www.etas.com/en/contact.php)

ETAS technical support WWW: [www.etas.com/en/hotlines.php](http://www.etas.com/en/hotlines.php)



---

## Figures

<b>Fig. 1-1</b>	WEEE symbol.....	7
<b>Fig. 2-1</b>	CBN420.2 Sensor cable diagram (top, Lemo connection), CBN421.2 (middle, Open Wire), and CBN422.2 (bottom, Molex connection) .....	14
<b>Fig. 3-1</b>	CBN420.2.....	20
<b>Fig. 3-2</b>	CBN421.2.....	20
<b>Fig. 3-3</b>	CBN422.2.....	20
<b>Fig. 3-4</b>	Lemo PHG.1B.304.CLLD .....	22
<b>Fig. 3-5</b>	Molex 51191-004.....	23



---

## Index

**A**

Accident prevention 5  
Ambient temperature 18

**C**

CE conformity declaration 6  
Channel assignment, application software 21  
Cleaning 6  
Configuration 16  
Configuration instructions 18  
Customer service 16

**D**

Data  
    mechanical 20  
    technical 17  
Documentation 5

**E**

Electrical data 18  
ES411.1 A/D module 12  
ETAS Contact Addresses 27  
ETAS measurement system 12

**H**

Hardware, system requirements 18  
Housing 15

**I**

Isolation, galvanic 12

**M**

Measurement channels 15  
Measurement channels, assignment of 21  
Measurement lines 15  
Measurement lines, labeling 22  
Mechanical data 20

**O**

Operating power 15  
Operation  
    Conventions 8  
Operation, requirements for 6

**P**

Power supply 18  
Product return 7  
Properties 12

**Q**

Qualification, required 5

**R**

Recycling 7  
RoHS conformity  
    China 6  
    European Union 6

**S**

Safety at work 5  
Safety instructions, basic 5  
Safety instructions, labeling 5  
Safety precautions 5  
Scope of delivery 8  
Serial number 16  
Signal conditioning 15  
Souriau plug 15, 21  
Splitter cable 15  
Standards and norms 17  
Structure 8  
System requirements 18

**T**

Technical data 17  
Test lab, accredited 13, 17  
Type testing, information on 17

**U**

Use, correct 5

**W**

Waste Electrical and Electronic Equip-  
ment - WEEE 7  
WEEE return system 7  
Wiring 16