

CBN410.2 / CBN411.2 / CBN413.2

Current Probe

User's Guide



Copyright

The data in this document may not be altered or amended without special notification from ETAS GmbH. ETAS GmbH undertakes no further obligation in relation to this document. The software described in it can only be used if the customer is in possession of a general license agreement or single license. Using and copying is only allowed in concurrence with the specifications stipulated in the contract.

Under no circumstances may any part of this document be copied, reproduced, transmitted, stored in a retrieval system or translated into another language without the express written permission of ETAS GmbH.

© **Copyright 2017** ETAS GmbH, Stuttgart

The names and designations used in this document are trademarks or brands belonging to the respective owners.

CBN41x.2 - User's Guide R07 EN - 10.2017

Contents

1	General	5
1.1	Basic Safety Instructions	5
1.1.1	Labeling of Safety Instructions	5
1.1.2	General Safety Information	5
1.1.3	Requirements for Users and Duties for Operators	5
1.1.4	Correct Use	6
1.2	RoHS conformity	7
1.2.1	European Union	7
1.2.2	China	7
1.3	Declarable Substances	7
1.4	CE labeling	7
1.5	Product Return and Recycling	8
1.6	Product Labeling	8
1.7	About this Manual	9
1.7.1	Structure	9
1.7.2	Using the Manual	9
1.8	Scope of Delivery	9
1.9	Additional Information	9
2	Hardware Description	10
2.1	Overview	10
2.1.1	Field of Application and Product Variants	10
2.1.2	Combined Use with the ES411.1 A/D Module	10
2.1.3	Properties	11
2.2	Assembly and Function	12
2.2.1	Current Probe Design	12
2.2.2	Splitter Cable	12
2.2.3	Measurement Channels	13
2.2.4	Measurement Line	13

2.2.5	Operating Power	13
2.2.6	Cable Identification	14
2.2.7	Serial Number	15
2.3	Wiring	15
3	Technical Data	16
3.1	General Data	16
3.1.1	Meets Standards and Norms	16
3.1.2	Type Test.	16
3.1.3	Environmental Conditions	17
3.1.4	Cleaning the Product.	17
3.2	System Requirements	17
3.2.1	Hardware	17
3.2.2	Power Supply	17
3.2.3	Software	18
3.3	Electrical Data	19
3.4	Mechanical Data	21
3.5	Measurement Line Assignment	22
3.6	Labeling of Measurement Lines	22
4	Ordering Information	23
4.1	CBN410.2	23
4.2	CBN411.2	23
4.3	CBN413.2	23
4.4	Calibration Service	23
5	ETAS Contact Addresses	24
	Figures	25
	Index	26

1 General

This chapter informs you about the basic safety information, product return and recycling, the use of this manual, the scope of delivery and other information.

1.1 Basic Safety Instructions

1.1.1 Labeling of Safety Instructions

The safety instructions contained in this manual are shown with the standard danger symbol shown below:



The following safety instructions are used. They provide extremely important information. Please read this information carefully.



WARNING!

indicates a possible medium-risk danger which could lead to serious or even fatal injuries if not avoided.



CAUTION!

indicates a low-risk danger which could result in minor or less serious injury or damage if not avoided.

1.1.2 General Safety Information

Please observe the product safety advice ("ETAS Safety Advice") and the subsequent safety instructions to avoid any impact on your health or damages to the device.

Note

Carefully read the documentation that belongs to the product prior to the startup.

ETAS GmbH does not assume any liability for damages resulting from improper handling, unintended use or non-observance of the safety precautions.

1.1.3 Requirements for Users and Duties for Operators

The product may be assembled, operated and maintained only if you have the necessary qualification and experience for this product. Improper use or use by a user without sufficient qualification can lead to damages or injuries to one's health or damages to property.

General safety at work

The existing regulations for safety at work and accident prevention must be followed.

1.1.4 Correct Use

This product has been developed and released for use in automotive applications. For usage in other domains please contact your ETAS representative.

Requirements for Operation

The following requirements are necessary for safe operation:

- Prior to assembly and operation, observe the notes for environmental requirements (see chapter 3.1.3 on page 17).
- Ensure compliance with the connected and settings values (see chapter 3.2.2 on page 17).
- Use the product only in accordance with the specifications in the relevant User's Guide. Any other usage could jeopardize product safety.
- Please comply with all electrical safety regulations and all health and safety laws and specifications valid at the place of use!
-
- Do not use the product in a wet or damp environment.
- Do not use the product in potentially explosive areas.
- Keep the surfaces of the product clean and dry.



WARNING!

This is a class A product. In a domestic environment this product may cause radio interference in which case the user may be required to take adequate measures.

Requirements for the technical State of the Product

The product is designed in accordance with state-of-the-art technology and recognized safety rules. The product may be operated only in a technically flawless condition and according to the intended purpose and with regard to safety and dangers as stated in the respective product documentation. If the product is not used according to its intended purpose, the protection of the product may be impaired.

Note

*If a Current Probe becomes damaged **immediately** remove it from operation!
Ensure that the damaged Current Probe is not used!
Repairing the Current Probe is not possible, attempts to make repairs are not permitted!*

Maintenance and cleaning

The product is maintenance-free. For cleaning, use a clean and dry cloth.

1.2 RoHS conformity

1.2.1 European Union

The EU Directive 2002/95/EU limits the use of certain dangerous materials for electrical and electronic devices (RoHS conformity).

This product does not contain any of the restricted substances specified in the EU Directive 2011/65/EU or exceeds the maximum concentrations stipulated therein. For individual electronic components used in our products, there are currently no equivalent alternative substances, which is why we make use of the exceptions 7A and 7C-I in Annex III of this Directive.

ETAS confirms that the product corresponds to this directive which is applicable in the European Union.

1.2.2 China

ETAS confirms that the product meets the product-specific applicable guidelines of the China RoHS (Management Methods for Controlling Pollution Caused by Electronic Information Products Regulation) applicable in China with the China RoHS marking affixed to the product or its packaging.

1.3 Declarable Substances

European Union

Some products from ETAS GmbH (e.g. modules, boards, cables) use components with substances that are subject to declaration in accordance with the REACH regulation (EU) no.1907/2006.

Detailed information is located in the ETAS download center in the customer information "REACH Declaration" (www.etas.com/Reach). This information is continuously being updated.

1.4 CE labeling

ETAS confirms that the product meets the product-specific, applicable European guideline with a CE label on the product or its packaging. CE conformity declaration for the product is available upon request.

1.5 Product Return and Recycling

The European Union (EU) issued the Waste Electrical and Electronic Equipment (WEEE) Directive to ensure the setup of systems for collecting, handling and processing electronic waste in all countries of the EU.

This ensures that the equipment is recycled in a resource-saving manner that does not represent any risk for the health and safety of humans and the environment.



Fig. 1-1 WEEE symbol

The WEEE symbol (see Fig. 1-1 on page 8) on the product or its packaging indicates that the product may not be disposed of with regular trash.





The user is obligated to separate the waste equipment and to provide it to the WEEE return system for reuse.

The WEEE guidelines apply to all ETAS devices, but not external cables or batteries.

Additional information on the ETAS GmbH recycling program is available from the ETAS sales and service department (see chapter 5 on page 24).

1.6 Product Labeling

The following symbols are used for product labeling:

Symbol	Description
	Prior to operating the product, be sure to read the user's guide!
	Labeling for RoHS (EU), see chapter 1.2.1 on page 7
	Labeling for CE conformity, see chapter 1.4 on page 7
	Labeling for RoHS (China), see chapter 1.2.2 on page 7

Please observe the information in chapter "Technical Data" on page 16.

1.7 About this Manual

This manual describes the operational and technical data for the Current Probe CBN41x.2.

1.7.1 Structure

This manual consists of four chapters and an index.

- **Chapter 1: "Introduction"**

This chapter provides you with information on basic safety notices, product return and recycling, how to use this manual, notes on the scope of delivery, and additional information.

- **Chapter 2: "Hardware Description"**

In this chapter you'll find an overview of product variants for the Current Probe CBN41x.2, information on combined implementation with the ES411.1 A/D module, the housing, connections, measurement channels, power supply, cable identification, serial number, as well as wiring.

- **Chapter 3: "Technical Data"**

This chapter describes the standards and norms met, the environmental requirements, system prerequisites for operation of the Current Probe CBN41x.2, electrical and mechanical data, assignment of measurement channels, and measurement line labeling.

- **Chapter 4: "Ordering Information"**

In this chapter you'll find information for ordering the Current Probe.

The concluding chapter "ETAS Contacts" provides you with information on international ETAS sales and service offices.

1.7.2 Using the Manual

Typographical conventions

The following typographical conventions are used:

Bold	Device labeling
<i>Italics</i>	Particularly important sections

Important notes for the user are displayed as follows:

Note

Important note for users.

1.8 Scope of Delivery

Before initial operation of your CBN41x.2, please verify that the device was delivered with all necessary parts (see chapter 4 on page 23).

1.9 Additional Information

The configuration instructions for the Current Probe CBN41x.2 under INCA can be found in the corresponding software documentation.

2 Hardware Description

In this chapter you'll find an overview of product variants for the Current Probe CBN41x.2, information on combined implementation with the ES411.1 A/D module, the housing, connections, measurement channels, power supply, cable identification, serial number, as well as wiring.

2.1 Overview

2.1.1 Field of Application and Product Variants

The growing number electric loads with higher power consumption in vehicle power circuit (turn signals, seat and windshield heating, seat adjustment, interior heating in vehicles with diesel direct injection motors, etc.) requires, among other things, measurement and monitoring of high operating currents when developing an on-board power supply.

The Current Probe CBN41x.2 was designed for these applications and is offered in three variants for different measurement ranges:

Current Probe	Measurement Range	
	Short-Term Operation	Continuous Operation
CBN410.2	±100 A	±60 A
CBN411.2	±5 A	±5 A
CBN413.2	±30 A	±25 A

Note

Complete technical data for the Current Probe CBN41x.2 can be found in chapter "Technical Data" on page 16.

Note

Descriptions, properties, and technical data in this manual apply to all variants of the Current Probe (CBN410.2, CBN411.2, and CBN413.2), insofar as not otherwise noted.

The shared abbreviation "CBN41x.2" is used in these text components.

Note

The three variants of the Current Probe are mechanically identical, except for the measurement line diameter.

2.1.2 Combined Use with the ES411.1 A/D Module

The Current Probe CBN41x.2 consists of four identical electrical measurement channels integrated into a splitter cable and intended for combined use with the ES411.1 A/D module.

Combination with the Current Probe expands the four ES411.1 module channels for measurement of higher currents, for example, in the vehicle system's on-board power supply.

The ES411.1 module assumes power supply for the Current Probe, the A/D conversion, and the time-synced transfer to a PC or application program.

The automatic setting of the measurement range prevents error measurements due to incorrect configuration.

The integration of the Current Probe CBN41x.2 into the ETAS measurement system and into INCA, provides an efficient solution for acquiring voltage when developing, applying, and validating electronic control of electric drives and loads with high power consumptions.

2.1.3 Properties

The most important properties of the Current Probe CBN41x.2, combined with the ES411.1 module:

- Use in combination with the ES411.1 A/D module
- Compact measurement probes for collecting currents in vehicles
- High safety due to galvanized isolation near measurement point
- Product variants with different measurement ranges:
 - CBN410.2: ± 100 A (short-term operation) or ± 60 A (continuous operation)
 - CBN411.2: ± 5 A (short-term/continuous operation)
 - CBN413.2: ± 30 A (short-term operation) or ± 25 A (continuous operation)
- Voltage supply to measurement channels integrated in the measurement cable
- when using ETAS application software
 - Automatic setting of voltage supply for the Current Probe through the ES411.1 A/D module,
 - Automatic transfer of individual alignment and calibration values for the combination of Current Probe and ES411.1 module,
 - Automatic setting of measurement range for the Current Probe in INCA
- Synchronized collection of control unit signals and other measurement data from the vehicle environment
- Automotive serviceable product suited for use in development environments and in vehicles on test tracks.
 - Adaptable to environmental conditions (temperature, EMC)
 - High mechanical stability and robustness
- Product safety during type testing and certification by an accredited test lab
- together with the ES411.1 module part of the ETAS Tool Suite.

Complete technical data for the Current Probe CBN41x.2 can be found in chapter "Technical Data" on page 16.

2.2 Assembly and Function

2.2.1 Current Probe Design

Note

The three variants of the Current Probe are mechanically identical, except for the measurement line diameter.

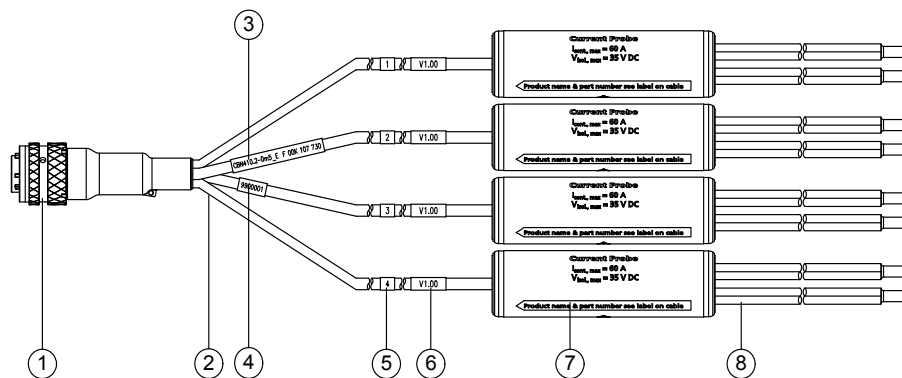

Fig. 2-1 Current Probe design

No. in Fig. 2-1	Designation
1	Souriau plug
2	Splitter cable
3	Product short name and type-parts number
4	Product serial number
5	Measurement channel number
6	Measurement channel hardware version number
7	Measurement channel housing
8	Measurement lines

Note

If a Current Probe becomes damaged **immediately** remove it from operation!
Ensure that the damaged Current Probe is not used!
 Repairing the Current Probe is not possible, attempts to make repairs are not permitted!

2.2.2 Splitter Cable

The Current Probe CBN41x.2 comes with a splitter cable on a Souriau plug (left), which is connected to four identical measurement channel housings (middle). On the opposite side of the measurement channel housing, two measurement lines (right) are located on each measurement channel.

2.2.3 Measurement Channels

The electronics for each of the four measurement channels are sealed in a separate cylindrical housing. The housings are labeled "7" in Fig. 2-1 on page 12. Signal conditioning of the incoming signals occurs in the measurement channels.

Different product variants are offered for different measurement ranges:

- ± 100 A (CBN410.2)
- ± 5 A (CBN411.2)
- ± 30 A (CBN413.2)

Note

Complete technical data for the Current Probe CBN41x.2 can be found in chapter "Technical Data" on page 16.

The four measurement channels of a Current Probe CBN41x.2 product variant are identical.

2.2.4 Measurement Line

Measurement line labeling

The Current Probe measurement lines are labeled with colors:

- Entry "+": red/bright red
- Entry "-": black/red

Measurement line contacts

The cable ends are outfitted with end sleeves. For measurement configuration contacts, the user can optionally shorten or finish the measurement channel cable ends (see Fig. 2-1 on page 12).

2.2.5 Operating Power

The ES411.1 A/D modules with sensor supply provides the Current Probe CBN41x.2 with operating power. The output voltage of the ES411.1 module (module sensor voltage supply) is used as the Current Probe voltage supply in this application.

Since there is a separate sensor supply connection for each of the ES411.1 A/D module's measurement channels, each of the four Current Probe CBN41x.2 measurement channels have separate operating power supply. The Current Probe power supply cables are integrated into the measurement cable.

2.2.6 Cable Identification

Functions when using ETAS application software (INCA)

If the Current Probe and the ES411.1 module are combined using ETAS application software (INCA), the following functions are implemented for each measurement channel:

- Automatic setting of voltage supply for the Current Probe through the ES411.1 A/D module,
- Automatic transfer of individual alignment and calibration values for the combination of Current Probe and ES411.1 module,
- Automatic setting of the measurement range for the Current Probe in INCA.

These functions are realized individually in each measurement channel through technology using processes according to TEDS standards.

Functionality when using ETAS configuration software and custom client application software

If the Current Probe and ES411.1 module combination is configured using ETAS configuration software (ES4xx Configuration Tool for stand-alone operations) and if it is operated by custom client application software, the following functions are implemented for each measurement channel:

- Automatic setting of voltage supply for the Current Probe through the ES411.1 A/D module,
- Provision of an A2L file for import into custom client application software with individual alignment and calibration values as well as the necessary measurement range for the combination of Current Probe and ES411.1 module.

With the information from the A2L file, the combination of Current Probe and ES411.1 module can be integrated into custom client application software.

Limitations when using custom client application software

If the Current Probe ES411.1 module combination is used with custom client application software, the product can only be used to a limited degree or with increased effort:

- The ES411.1 module output voltage (module sensor supply voltage) being used as the Current Probe voltage supply must be set manually to 12 V.
- Alignment and calibration for the Current Probe and ES411.1 module combination must be manually entered in the custom client application software by the user for each module.
ETAS will provide these values upon request.
- The information required to automatically set the measurement range for the Current Probe can only be read from the ES411.1 module with ETAS application software. Clients using their own application software must therefore manually set the measurement range.

2.2.7 Serial Number

The Current Probe CBN41x.2 serial number is located near the Souriau plug on the splitter cable (No. 4 in Fig. 2-1 on page 12). You will need it when contacting ETAS technical customer service.

The CBN41x.2 Current Probe serial number is not used in the ETAS application software.

2.3 Wiring

The Souriau plug of the Current Probe CBN41x.2 is connected directly to the ES411.1 A/D module. Longer connections in the measurement design can be realized with the ES411.1 module Daisy Chain wiring.

3 Technical Data

This chapter describes the standards and norms met, the environmental conditions, system requirements for operation of the Current Probe CBN41x.2, electrical and mechanical data, measurement channel assignment, and measurement line labeling.

Note

Information for module ES411.1 can be found in the user's guide "ES411.1 A/D module with sensor supply".

3.1 General Data

3.1.1 Meets Standards and Norms

The Current Probe CBN41x.2 connected to the ES411.1 module meets the following standards and norms:

Norm	Test
EN 61010-1	Safety regulations for electrical measurement, control, monitoring, and laboratory devices
EN 61326	Electrical equipment for measurement, control and laboratory use - EMC requirements
EN 61000-6-2	Interference immunity (industrial environments) ¹⁾
EN 61000-6-4	Interference emission (industrial environments)

¹⁾: The module must be supplied by a DC voltage mains adaptor or a battery with operating power. Cables with a maximum length of 30 m are permitted between module and power source.

The Current Probe CBN41x.2 is designed only for use in industrial environments in accordance with EN 61000-6-4. When using the module outside of industrial environments avoid possible radio disturbances by additional shielding measures!



WARNING!

This is a class A product. In a domestic environment this product may cause radio interference in which case the user may be required to take adequate measures.

3.1.2 Type Test

The Current Probe CBN41x.2 was type tested and certified by an accredited test lab. Information on product type testing are available from ETAS upon request.

3.1.3 Environmental Conditions

Operating temperature range	-40 °C to +85 °C
	-40 °F to +185 °F
Altitude	max. 5000 m / 16400 ft
Relative humidity (non-condensation)	0 to 95%
Protection class	IP65

3.1.4 Cleaning the Product

We recommend to clean the product with a dry cloth.

3.2 System Requirements

3.2.1 Hardware

Note

The CBN41x.2 Current Probe is only intended for use in the ES411.1 A/D module with sensor supply.

ES411.1 module hardware version requirements

For complete support of the Current Probe ES411.1 module combination in the application software, a compatible ES411.1 module hardware version (hardware version) is required.

Note

Before using the Current Probe, check the ES411.1 module hardware version.

A sticker with the module's hardware version is located on the bottom of the module. There is also a possibility to call up the hardware version with the "HSP Update Tool" service software.

Hardware Version	Note	Functionality With Current Probe
V3.x and newer	Current HW version	Normal functionality
V2.x	Updated module	Normal functionality
V1.x	Older HW versions	Hardware update required. Please send module to ETAS.

3.2.2 Power Supply

The ES411.1 A/D module with sensor supply provides the CBN41x.2 Current Probe with operating power via the Souriau plug. No other cables are necessary. The output voltage of the ES411.1 module (module sensor voltage supply) is used as the Current Probe voltage supply in this application.

3.2.3 Software

Module ES411.1 firmware requirements

In order for the Current Probe to be supported in the ES411.1 modules, the ES411.1 module requires firmware with expanded functionality. This firmware is delivered with the "HSP Update Tool" service software for versions V9.7.0 and higher.

Update your ES411.1 modules with older firmware versions with HSP V9.7.0 or higher.

Application software requirements

Configuring and controlling as well as collecting data with the ES411.1 in combination with the CBN41x.2 Current Probe, requires a ES411.1 module with updated firmware and software in the following versions:

- INCA V7.0 with INCA AddOn ES4xx V1.3.2 and higher
or
- ES4xx Configuration Tool V1.3.2 and higher from ES4xx_DRV_SW (stand alone operation)
or
- Clients using their own application software not supporting the XCP-on-Ethernet, must supplement this software with a C-based library (C-API) for the integration of XCP-on-Ethernet drivers. The C-based library is available at ETAS.

Note

Operating the CBN41x.2 Current Probe when connected to the ES411.1 module is not possible with older software versions.

Limitations when using custom client application software

If the Current Probe ES411.1 module combination is operated with custom client application software, the product can only be used to a limited degree or with increased effort. Observe the notes regarding this in chapter 2.2.6 on page 14.

Additional information

Configuration instructions for the ES411.1 A/D module can be found in the corresponding software documentation.

3.3 Electrical Data

Note

Insofar as not otherwise indicated, all data apply for 25 °C and for operation of the CBN41x.2 Current Probe with the ES411.1 module.

Parameter	Symbol	Conditions	Min.	Type	Max.	Unit
Forward resistance	R_{fw}	CBN410.2, at end of cable		0.2	0.8	mΩ
		CBN411.2, at end of cable		3.5	5	mΩ
		CBN413.2, at end of cable		3.5	5	mΩ
Isolation voltage	U_{iso}	Input to supply minus of the ES411.1 module			±35	V
Measurement range	I_{in}	CBN410.2	-100		100	A
		CBN411.2	-5		5	A
		CBN413.2	-30		30	A
Max. current	I_{max}	CBN410.2, continuous		60		A
		CBN410.2, t < 10 s		100		A
		CBN410.2, t < 10 ms		600		A
		CBN411.2, continuous		5		A
		CBN413.2, continuous		25		A
		CBN411.2, CBN413.2, t < 10 s		30		A
		CBN411.2, CBN413.2, t < 10 ms		100		A

Parameter	Symbol	Conditions	Min.	Type	Max.	Unit
Maximum measurement error (CBN41x.2 with ES411.1 module)		CBN410.2			±0.25 A at $I_{in} = 0$ A	
					±0.5 A at $I_{in} = \pm 50$ A	
		CBN411.2			±0.1 A at $I_{in} = 0$ A	
					±0.11 A at $I_{in} = \pm 5$ A	
		CBN413.2			±0.1 A at $I_{in} = 0$ A	
					±0.22 A at $I_{in} = \pm 20$ A	
Maximum measurement error over temperature range -40 °C to +85 °C		CBN410.2			±1.6 A at $I_{in} = 0$ A	
					±4.2 A at $I_{in} = \pm 50$ A	
		CBN411.2			±0.4 A at $I_{in} = 0$ A	
					±0.5 A at $I_{in} = \pm 5$ A	
		CBN413.2			±0.75 A at $I_{in} = 0$ A	
					±1.4 A at $I_{in} = \pm 20$ A	
Bandwidth	f_c	-3 dB		25		kHz
Noise (effective)	$I_{N, eff}$	CBN410.2, 4 kHz bandwidth			6	mA
		CBN411.2, CBN413.2, 4 kHz bandwidth			10	mA
Calibration interval		Product within specification	1			Year

Magnetic influences, for example caused by the earth magnetic field, can cause additional measurement errors because of the magnetic measurement principle.

3.4 Mechanical Data

Note

The electrical gauge heads CBN410.2, CBN411.2, and CBN413.2 are mechanically identical, with the exception of their measurement line diameters. Dimensions and weight of these electrical gauge heads are identical.

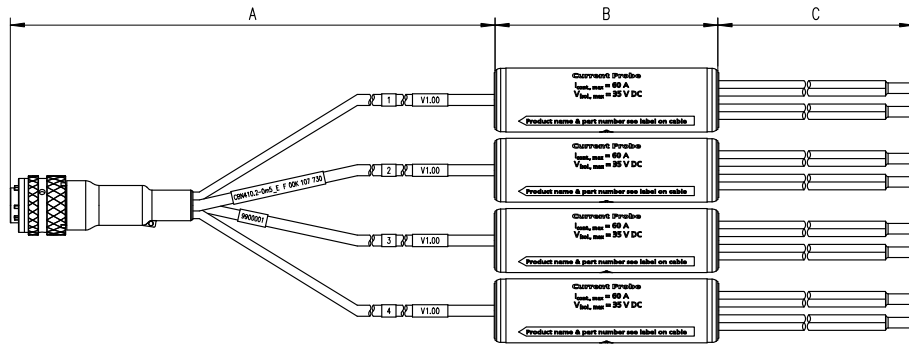

Fig. 3-1 CBN410.2

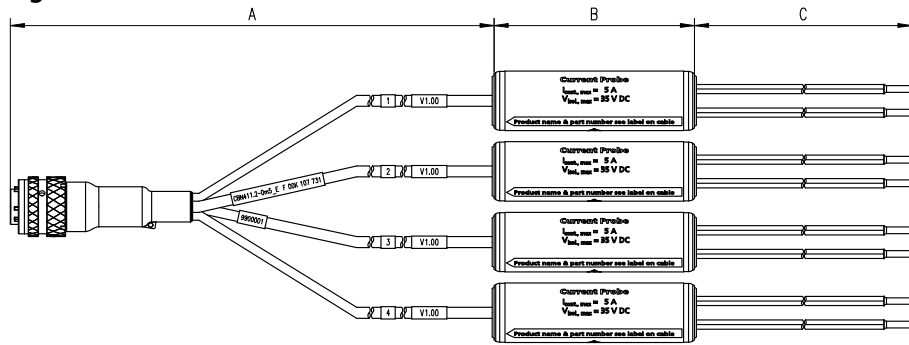

Fig. 3-2 CBN411.2

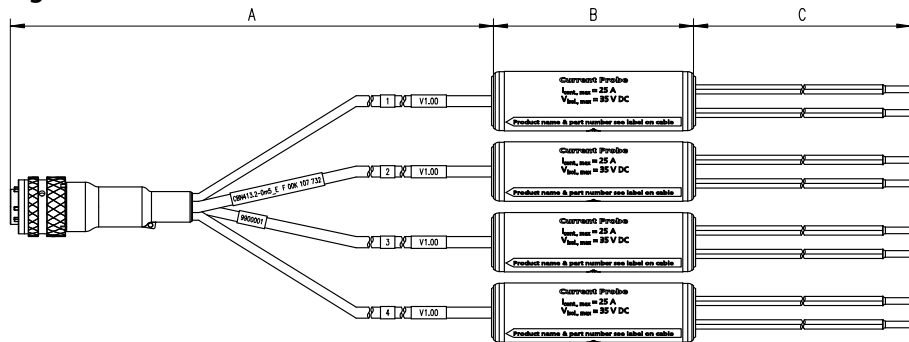

Fig. 3-3 CBN413.2

Dimensions (see illustrations above)	CBN410.2: A: 255 mm (straight length; connection to ES411.1)
	CBN411.2, CBN413.2: A: 265 mm (straight length; connection to ES411.1)
	CBN410.2: B: 95 mm (diameter: 27 mm)
Connection line diameter	CBN411.2, CBN413.2: B: 85 mm (diameter: 25 mm)
	C: 150 mm (measurement lines)
	CBN410.2: 10 mm ² CBN411.2, CBN413.2: 4 mm ²
Weight	CBN410.2: approx. 515 g
	CBN411.2: approx. 335 g
	CBN413.2: approx. 335 g

3.5 Measurement Line Assignment

The four identical active electric measurement channels of the electrical gauge heads CBN41x.2 are labeled 1 through 4 on the side of the splitter cable with the Souriau plug (see illustration in chapter 3.4). The assignment of electric gauge head measurement channels to the ES411.1 measurement channels is presented in the following table.

CBN41x.2 Measurement Channel	ES411.1 Measurement Channel
1	1
2	2
3	3
4	4

This channel assignment is used in the application software.

3.6 Labeling of Measurement Lines

The measurement lines of the electrical gauge heads are labeled with colors:

Measurement Line	Labeling
Entry "+"	red/bright red
Entry "-"	black/red

4 Ordering Information

4.1 CBN410.2

Order name	Short name	Order number
CBN410.2 Current Probe, ± 100 A range, 4 Channels, Souriau 8ST12-35 4xOpen Wire, 0.5 m	CBN410.2-0m5	F 00K 107 722

Scope of supply

- CBN410.2 Current Probe (± 100 A range)
- ETAS Safety Advice
- Calibration Certificate
- China-RoHS-leaflet_Compact_green_cn

4.2 CBN411.2

Order name	Short name	Order number
CBN411.2 Current Probe, ± 5 A range, 4 Channels, Souriau 8ST12-35 4xOpen Wire, 0.5 m	CBN411.2-0m5	F 00K 107 723

Scope of supply

- CBN411.2 Current Probe (± 5 A range)
- ETAS Safety Advice
- China-RoHS-leaflet_Compact_green_cn
- Calibration-Certification

4.3 CBN413.2

Order name	Short name	Order number
CBN413.2 Current Probe, ± 30 A range, 4 Channels, Souriau 8ST12-35 4xOpen Wire, 0.5 m	CBN413.2-0m5	F 00K 107 724

Scope of supply

- CBN413.2 Current Probe (± 30 A range)
- ETAS Safety Advice
- China-RoHS-leaflet_Compact_green_cn
- Calibration-Certification

4.4 Calibration Service

Order name	Short name	Order number
Calibration Service for CBN410.2	K_CBN410	F 00K 107 942
Calibration Service for CBN411.2	K_CBN411	F 00K 107 943
Calibration Service for CBN413.2	K_CBN413	F 00K 107 944

5 **ETAS Contact Addresses**

ETAS HQ

ETAS GmbH

Borsigstraße 14

70469 Stuttgart

Germany

Phone: +49 711 3423-0

Fax: +49 711 3423-2106

WWW: www.etas.com

ETAS Subsidiaries and Technical Support

For details of your local sales office as well as your local technical support team and product hotlines, take a look at the ETAS website:

ETAS subsidiaries WWW: www.etas.com/en/contact.php

ETAS technical support WWW: www.etas.com/en/hotlines.php

Figures

Fig. 1-1	WEEE symbol.....	8
Fig. 2-1	Current Probe design.....	12
Fig. 3-1	CBN410.2.....	21
Fig. 3-2	CBN411.2.....	21
Fig. 3-3	CBN413.2.....	21

Index

A

Accident prevention 5
Ambient temperature 17
Application software 18

C

Cable identification 14
CE conformity declaration 7
Channel assignment, application software 22
Cleaning 6
Configuration instructions 18
Customer service 15

D

Data
 mechanical 21
 technical 16
Documentation 5

E

Electrical data 19
ES411.1 A/D module 10
ETAS Contact Addresses 24
ETAS measurement system 11

F

Firmware 18

H

Hardware version, compatible 17
Hardware version, sticker 17
Hardware, system requirements 17

Housing 13

M

Measurement channels 13
Measurement channels, assignment of 22
Measurement line 13
Measurement lines, labeling of 22
Mechanical data 21

O

Operating power 13
Operation
 Conventions 9
Operation, requirements for 6

P

Power supply 17
Product return 8
Properties 11

Q

Qualification, required 5

R

REACH regulation (EU) 7
Recycling 8
RoHS conformity
 China 7
 European Union 7

S

Safety at work 5

Safety instructions, basic 5
Safety instructions, labeling 5
Safety precautions 5
Scope of delivery 9
Serial number 15
Signal conditioning 13
Souriau plug 12, 22
Splitter cable 12
Standards and norms 16
Structure 9
System requirements 17

T
Technical data 16
Test lab, accredited 11, 16
Type testing, information on 16

U
Use, correct 6

W
Waste Electrical and Electronic Equip-
ment - WEEE 8
WEEE return system 8