

# RTA-OS

## PowerPCe200 Cores with the WindRiver Compiler

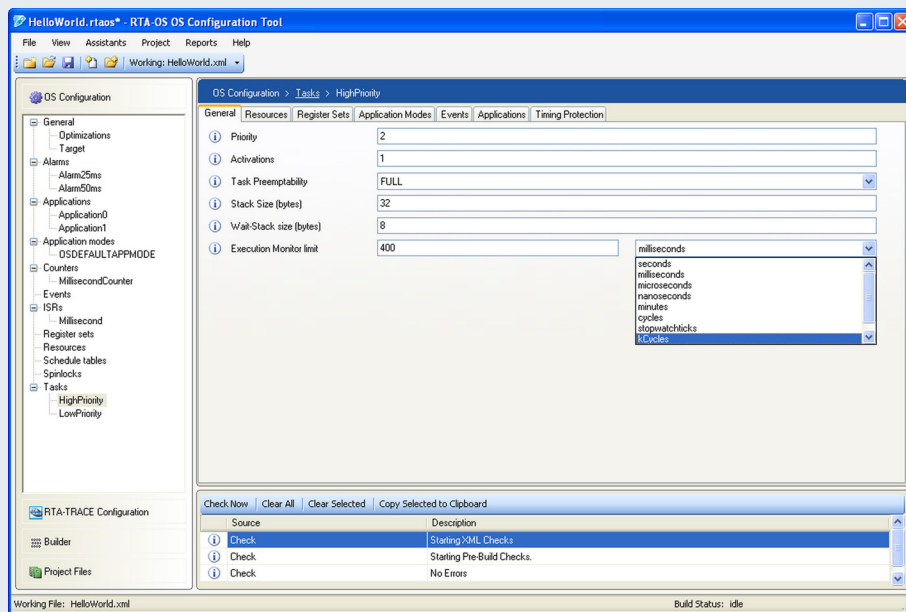

### Features at a Glance

AUTOSAR R4.0 compliant  
Multicore OS

Supports all scalability  
classes

MISRA-C:2012 compliant

RTOS overhead:  
69 bytes RAM  
0 bytes ROM

Category 2 ISR latency:  
82 CPU cycles

### RTA-OS

RTA-OS is the new generation operating system from ETAS that conforms to the AUTOSAR OS specification and builds on the benefits of the successful RTA-OSEK product. It provides a toolsuite that includes a PC-based graphical configuration tool and adaptive OS generation capabilities to deliver flexible, fast solutions for a wide range of automotive microcontrollers.

The graphical configuration tool allows all OS objects to be configured, and creates AUTOSAR conformant XML files describing the OS configuration. In addition, it provides automatic verification against the AUTOSAR XML schema and allows users to create projects for easy management of multiple files.

RTA-OS improves on RTA-OSEK in several areas, including better runtime performance and smaller memory footprint, support for multiple processor environments, and automatic support for up to 1024 tasks. The po-

werful performance analysis tools developed for RTA-OSEK have been updated for RTA-OS to allow hard real-time requirements to be met.

### RTA Product Family

RTA-OS integrates seamlessly with other tools in the RTA product family, including:

- RTA-RTE – a mature, robust production quality AUTOSAR RTE Generator.
- RTA-TRACE – a software logic analyser that allows the runtime behaviour of RTA-OS to be observed.

### Microcontroller Support

RTA-OS supports all variants of the PowerPCe200 family of microcontrollers.

Release testing has taken place using the MPC5676R and MPC5746M variants.

## Compiler Toolchain

RTA-OS for the PowerPCe200 Cores has been developed with the WindRiver v5.9.6.2 compiler.

Due to the adaptive code generation of RTA-OS, it is possible to use other versions of this compiler to build applications.

## ORTI Debugger Support

RTA-OS can generate OSEK Runtime Interface information for the Lauterbach Trace32 debugger.

## Interrupt Model

RTA-OS supports 16 levels of nested interrupts on the PowerPCe200 Cores.

## Memory Model

RTA-OS supports a flat 32 bit address space

## Multicore Support

RTA-OS supports both single and multicore PowerPCe200 devices.

## Maximum Number of OS Objects Allowed by RTA-OS

	BCC1	BCC2	ECC1	ECC2
Max. no. of tasks		Up to 1024		
Max. tasks per priority		Up to 1024		
Max. queued activations	1	$2^{32}-1$	1	$2^{32}-1$
Max. events per task	n/a	n/a	32	32
Max. alarms		$2^{32}-1$		
Max. software counters		$2^{32}-1$		
Max. hardware counters		$2^{32}-1$		
Max. nested resources		$2^{32}-1$		
Max. standard resources		$2^{32}-1$		
Max. internal resources		Not limited by RTA-OS		
Max. application modes		$2^{32}-1$		
Max. schedule tables		$2^{32}-1$		
Max. expiry points per schedule table		$2^{32}-1$		

## Memory Overhead of RTA-OS

Memory Type	Overhead (bytes)
RAM	0
ROM/Flash	69

In addition to the OS overhead, each object used by a single-core application has the following memory requirements:

Object	RAM (bytes)	ROM (bytes)
Task	0	16
Category 2 ISR	0	8
Resource	4	8
Alarm	12	2
Counter	4	20
Schedule Table	16	16
Expiry Point	0	4

## Performance

The following table gives the key RTA-OS kernel performance data measured in CPU cycles. All measurements were taken on an NXP MPC5746Mv2 with a 16MHz clock speed.

Task Type	Execution Time	Ref.
Pre-emption	183	A
Normal Termination	112	B
Task Switch	132	C
ChainTask	244	D
WaitEvent	563	E
SetEvent	731	F
Schedule	188	G
ReleaseResource	177	H
Category 2 ISR Entry Latency	82	I
Category 2 ISR Exit Latency resuming interrupted task	169	J
Category 2 ISR Exit Latency with task switch	209	K
Category 1 ISR Latency	29	L

The following figures illustrate how the RTA-OS kernel overheads are allocated during the operations given in the above table:

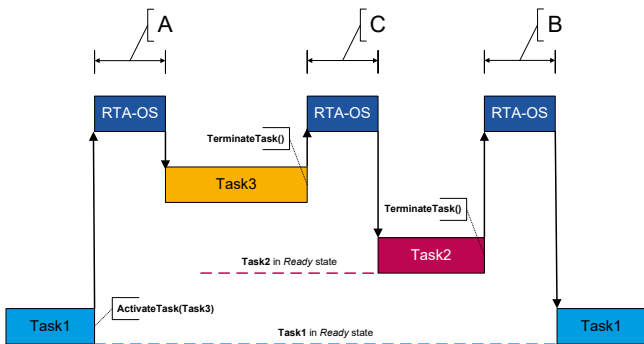

Figure 1 - Task1 is preempted by Task3, followed by a task switch and then normal termination of Task2

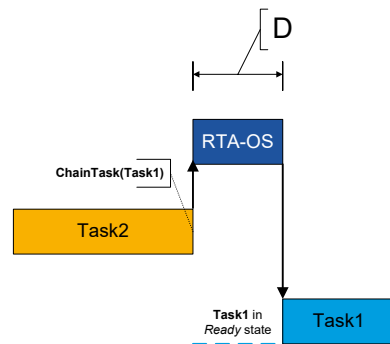

Figure 2 - Task2 chains Task1

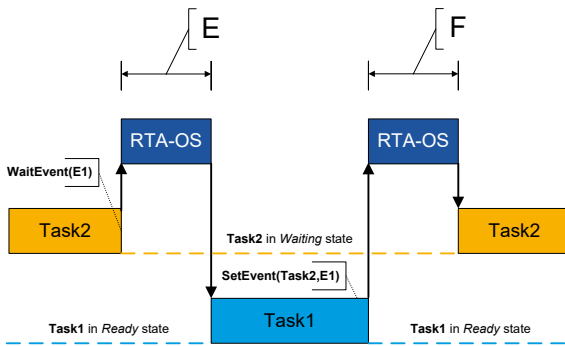

Figure 3 - Task2 waits for an event set by Task1

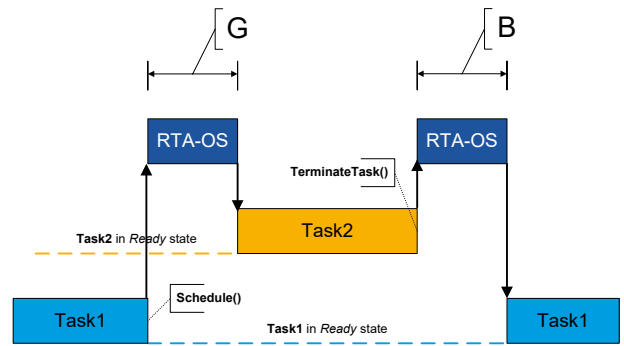

Figure 4 - Task1 allows cooperative scheduling by Task2

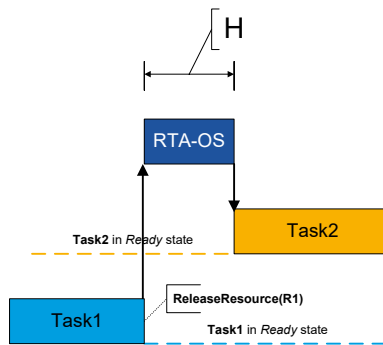

Figure 5 - Task1 releases a resource

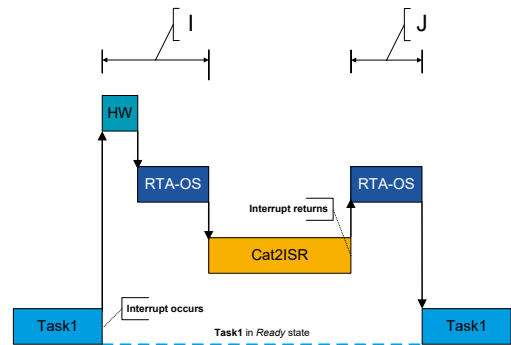

Figure 6 - Category2 ISR entry and exit latency

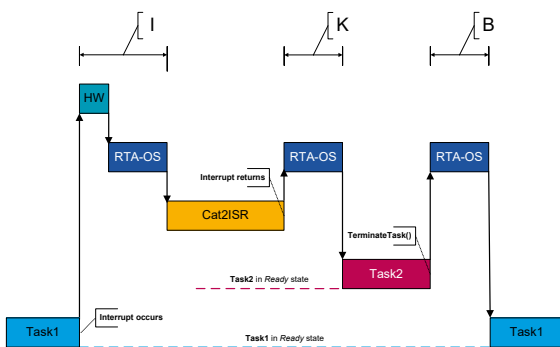

Figure 7 - Category2 ISR switches to Task2

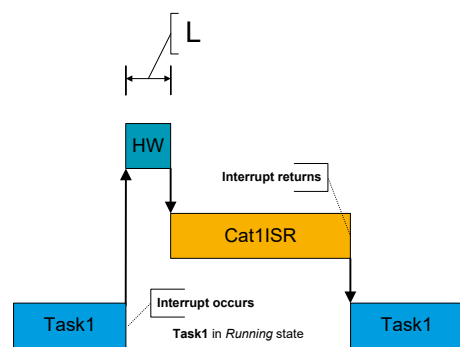

Figure 8 - Category1 ISR entry latency

## Order Information

To use RTA-OS it is necessary to purchase a development license for the tools together with an add-on license for the PowerPCe200/WindRiver port. Machine-named, user-named and floating licenses are available.

To use any operating system code generated by RTA-OS in ECU applications, a valid production license is required. Please contact your local ETAS Sales Office for details of production licenses for RTA-OS.

## RTA-OS Tools Order Information

Item	Characteristics	Object
F 00K 107 119	Machine-named license for RTA-OS for Windows PC	LD_RTA-OS_VRTA_SC34_LIC-MP
F 00K 107 120	User-named license for RTA-OS for Windows PC	LD_RTA-OS_VRTA_SC34_LIC-UP
F 00K 107 121	Floating license for RTA-OS for Windows PC	LD_RTA-OS_VRTA_SC34_LIC-CP
F 00K 107 136	Product CD for RTA-OS	LD_RTA-OS_VRTA_SC34_PROD

## RTA-OS PowerPCe200 Cores Port Order Information

Item	Characteristics	Object
F 00K 108 411	Machine-named license for RTA-OS for PowerPCe200/WindRiver Scalability Classes 1 & 2	ES_RTA-OS_PPCE200WR_SC12_LIC-MP
F 00K 108 414	User-named license for RTA-OS for PowerPCe200/WindRiver Scalability Classes 1 & 2	ES_RTA-OS_PPCE200WR_SC12_LIC-UP
F 00K 108 420	Floating license for RTA-OS for PowerPCe200/WindRiver Scalability Classes 1 & 2	ES_RTA-OS_PPCE200WR_SC12_LIC-CP
F 00K 108 421	Machine-named license for RTA-OS for PowerPCe200/WindRiver Scalability Classes 1 to 4	ES_RTA-OS_PPCE200WR_SC34_LIC-MP
F 00K 109 422	User-named license for RTA-OS for PowerPCe200/WindRiver Scalability Classes 1 to 4	ES_RTA-OS_PPCE200WR_SC34_LIC-UP
F 00K 108 423	Floating license for RTA-OS for PowerPCe200/WindRiver Scalability Classes 1 to 4	ES_RTA-OS_PPCE200WR_SC34_LIC-CP
F 00K 108 424	Product CD for RTA-OS for PowerPCe200/WindRiver	ES_RTA-OS_PPCE200WR_PROD

### ETAS GmbH

70469 Stuttgart, Germany  
 Phone +49 711 3423-0  
 Fax +49 711 3423-2106  
 sales.de@etas.com

### ETAS S.A.S.

93404 Saint-Ouen Cedex  
 France  
 Phone +33 1 75 34 50-50  
 Fax +33 1 40 10 11-64  
 sales.fr@etas.com

### ETAS Ltd.

Derby DE21 4SU  
 United Kingdom  
 Phone +44 1332 253770  
 Fax +44 1332 253779  
 sales.uk@etas.com

### ETAS Inc.

Ann Arbor, MI 48103, USA  
 Phone +1 888 ETAS INC  
 Fax +1 734 997-9449  
 sales.us@etas.com

### ETAS K.K.

Yokohama 220-6217, Japan  
 Phone +81 45 222-0900  
 Fax +81 45 222-0956  
 sales.jp@etas.com

### ETAS Korea Co., Ltd.

Gyeonggi-do 13488, Korea  
 Phone +82 31 326 6200  
 Fax +82 31 326 6209  
 sales.kr@etas.com

### ETAS (Shanghai) Co., Ltd.

Shanghai 200335, P.R. China  
 Phone +86 21 2218 5858  
 Fax +86 21 5037 2221  
 sales.cn@etas.com

### ETAS Automotive India Pvt. Ltd.

Bangalore 560 068, India  
 Phone +91 80 6783 6333  
 Fax +91 80 6783 6424  
 sales.in@etas.com

www.etas.com