

# ETAS FETK-T5.0A

## Emulator Probe for NXP S32 Family



User Guide

## Copyright

The data in this document may not be altered or amended without special notification from ETAS GmbH. ETAS GmbH undertakes no further obligation in relation to this document. The software described in it can only be used if the customer is in possession of a general license agreement or single license. Using and copying is only allowed in concurrence with the specifications stipulated in the contract.

Under no circumstances may any part of this document be copied, reproduced, transmitted, stored in a retrieval system or translated into another language without the express written permission of ETAS GmbH.

**© Copyright 2024** ETAS GmbH, Stuttgart

The names and designations used in this document are trademarks or brands belonging to the respective owners.

FETK-T5.0A I User Guide R04 EN - 03.2024

## Contents

1	Safety Information.....	7
1.1	Intended Use.....	8
1.2	Classification of Safety Messages.....	8
1.3	Safety Information.....	9
1.3.1	Assembly.....	9
1.3.2	Operation.....	9
1.3.3	Electrical Connection.....	9
1.3.4	Cables and Accessories.....	10
1.3.5	Transport.....	11
1.3.6	Maintenance.....	11
1.4	Identifications on the Product.....	11
1.5	Taking the Product Back and Recycling.....	12
1.6	Declaration of Conformity.....	12
1.6.1	CE Declaration of Conformity (European Union).....	12
1.6.2	UKCA Declaration of Conformity (Great Britain).....	12
1.7	RoHS Conformity.....	12
1.7.1	European Union.....	12
1.7.2	People's Republic of China.....	13
1.8	Declarable Substances.....	13
1.9	Use of Open Source Software.....	13
2	Introduction.....	14
2.1	Applications.....	14
2.2	Features.....	14
2.2.1	General.....	14
2.2.2	Measurement.....	15
2.2.3	Calibration.....	15
2.2.4	Further Characteristics.....	16
3	Hardware Description.....	17
3.1	Architecture.....	17
3.2	ECU Interface.....	18
3.3	FETK Ethernet Interface.....	19
3.4	Power Supply.....	20
3.5	ECU Voltage Supervisor.....	20
3.6	Status LEDs.....	21
3.7	Data Access.....	22
3.7.1	Calibration Data Access.....	22
3.7.2	Measurement Data Access.....	23
3.8	JTAG Interface.....	24
3.9	Trace Interface.....	24
3.10	Trigger Modes.....	25
3.10.1	Overview.....	25
3.10.2	Triggering via Trace Interface.....	25
3.10.3	Pinless Triggering.....	26

## 4 | Contents

3.10.4	Timer Triggering .....	26
3.11	Startup Handshake .....	27
3.12	Reset .....	27
3.13	Pull CalWakeUp until Startup Handshake .....	27
4	Installation .....	28
4.1	Mounting the FETK-T5.0A into the ECU Housing .....	28
4.1.1	Thermal Connection Requirements .....	28
4.1.2	Mounting Material .....	28
4.1.3	Mounting Steps .....	29
4.2	Connection to the ECU .....	31
4.3	Wiring .....	33
4.3.1	FETK Ethernet Interface .....	33
4.4	Power Supply .....	33
5	ETK / XETK / FETK Configuration .....	37
5.1	Overview .....	37
5.2	Configuration Parameter .....	38
6	Troubleshooting .....	39
6.1	Problems and Solutions .....	39
6.1.1	No communication between the ECU and ETK .....	39
7	Technical Data .....	40
7.1	System Requirements .....	40
7.1.1	ETAS Compatible Hardware .....	40
7.1.2	PC with one Ethernet Interface .....	40
7.1.3	Software Requirements .....	41
7.2	Data Emulation and Measurement Memory .....	41
7.2.1	Memory for Data Emulation .....	41
7.2.2	Measurement Data Memory .....	41
7.2.3	Trace Memory .....	42
7.3	Environmental Conditions .....	42
7.4	FETK Ethernet Interface .....	43
7.5	Power Supply .....	45
7.6	Microcontroller Interface .....	45
7.7	Test Characteristics .....	46
7.8	JTAG Timing Characteristics .....	47
7.9	Aurora Trace Timing Characteristics .....	47
7.10	Electrical Characteristics .....	48
7.10.1	ECU Interface Connector (JTAG) .....	48
7.10.2	ECU Interface Connector Aurora Trace .....	49
7.11	Pin Assignment .....	50
7.11.1	ECU Interface Connector CON1 (JTAG) .....	50
7.11.2	ECU Interface Connector CON2 (Aurora Trace) .....	52
7.11.3	Ethernet Interface Connector CON3 .....	53
7.11.4	Power Supply Connector CON4 .....	53

7.12	Mechanical Dimensions .....	54
7.12.1	Top View .....	54
7.12.2	Side View .....	55
8	Cables and Accessories .....	56
8.1	Overview and Classification .....	56
8.2	Requirements for failsafe Operation .....	56
8.3	CBAM300 Cable .....	57
8.3.1	Usage .....	57
8.3.2	Connectors .....	57
8.3.3	Temperature Range .....	57
8.3.4	Tightness .....	57
8.3.5	Ordering .....	57
8.4	CBAM320 Cable .....	58
8.4.1	Usage .....	58
8.4.2	Connectors .....	58
8.4.3	Temperature Range .....	58
8.4.4	Tightness .....	58
8.4.5	Ordering .....	58
8.5	CBAM340 Cable .....	59
8.5.1	Usage .....	59
8.5.2	Connectors .....	59
8.5.3	Temperature Range .....	59
8.5.4	Ordering .....	59
8.6	CBAM350 Cable .....	60
8.6.1	Usage .....	60
8.6.2	Panel Cut-Out .....	60
8.6.3	Assembling .....	60
8.6.4	Temperature Range .....	61
8.6.5	Ordering .....	61
8.7	CBAM305 Cable .....	62
8.7.1	Usage .....	62
8.7.2	Dimensions .....	62
8.7.3	Connectors .....	63
8.7.4	Temperature Range .....	64
8.7.5	Tightness .....	64
8.7.6	Ordering .....	64
8.8	CBE260 Cable .....	65
8.8.1	Usage .....	65
8.8.2	Dimensions .....	65
8.8.3	Connectors .....	65
8.8.4	Temperature Range .....	65
8.8.5	Ordering .....	65
8.9	ETAM4 Adapter .....	66
8.9.1	Usage .....	66
8.9.2	Pin Numbering .....	66
8.9.3	Ordering .....	66
8.10	ETAM8 Adapter .....	67
8.10.1	Usage .....	67
8.10.2	Pin Numbering .....	67
8.10.3	ECU Connector: Signal Modes .....	67
8.10.4	Temperature Range .....	68

8.10.5	Ordering .....	68
8.11	ETV5 Cable .....	69
8.11.1	Usage .....	69
8.11.2	Pin Assignment .....	69
8.11.3	Temperature Range .....	69
8.11.4	Ordering .....	69
8.12	ETAM2 Adapter .....	70
8.12.1	Pin Assignment .....	70
8.12.2	ECU Signals .....	70
8.12.3	Ordering .....	70
8.13	ETAM5 Adapter .....	71
8.13.1	Pin Assignment .....	71
8.13.2	Ordering .....	71
8.14	ETAM9 Adapter .....	72
8.14.1	Usage .....	72
8.14.2	ECU Signals .....	72
8.14.3	Temperature Range .....	72
8.14.4	Order Information .....	72
8.15	ETAM10/ETAM12 Adapter .....	73
8.15.1	Usage .....	73
8.15.2	Mechanical Dimensions .....	73
8.15.3	Dimensions .....	73
8.15.4	ECU Signals .....	74
8.15.5	Temperature Range .....	74
8.15.6	Order Information .....	74
9	Ordering Information .....	75
9.1	FETK-T5.0A .....	75
9.2	Cable .....	75
9.2.1	ECU Adapter Cable .....	75
9.2.2	ECU Adapter and Power Supply Cable .....	76
9.2.3	Gbit Ethernet and Power Supply Cable .....	76
9.2.4	ECU Adapter .....	76
9.2.5	Power Supply Cable .....	76
9.3	Isolated Power Supply (ETP2) .....	77
10	Contact Information .....	78
	Figures .....	79
	Index .....	81

# 1 Safety Information

This chapter contains information about the following topics:

- Intended Use ..... 8
- Classification of Safety Messages ..... 8
- Safety Information ..... 9
- Identifications on the Product ..... 11
- Taking the Product Back and Recycling ..... 12
- Declaration of Conformity ..... 12
- RoHS Conformity ..... 12
- Declarable Substances ..... 13
- Use of Open Source Software ..... 13

Refer to the following safety instructions and the technical documentation available to download from the ETAS website [www.etas.com](http://www.etas.com). Keep the information provided in a safe place.

Failure to comply with the safety instructions may lead to the risk of damage to life and limb or property. The ETAS Group and its representatives shall not be liable for any damage or injury caused by improper operation or use of the product.

Only use the product if you have read and understood the information concerning safe operation and have the required qualifications and training for this product. If you have questions about safe operation, contact ETAS:

- Technical Support: [www.etas.com/hotlines](http://www.etas.com/hotlines)
- ETAS contact partners by region: [www.etas.com/contact](http://www.etas.com/contact)

The product is only approved for the applications described in the technical documentation. When using and operating this product, all applicable regulations and laws must be observed.

ETAS products made available as beta versions or prototypes of firmware, hardware and/or software are to be used exclusively for testing and evaluation purposes. These products may not have sufficient technical documentation and not fulfill all requirements regarding quality and accuracy for market-released series products. The product performance may therefore differ from the product description. Only use the product under controlled testing and evaluation conditions. Do not use data and results from beta versions without prior and separate verification and validation and do not share them with third parties.

Before starting up the product, check whether there is a Known Issue Report (KIR) for that product version: [www.etas.com/kir](http://www.etas.com/kir) (password: KETASIR). Note the information given in the report.

Program codes or program control sequences that are created or changed via ETAS products, as well as all types of data obtained through the use of ETAS products, must be checked for their reliability and suitability prior to use or distribution. Only use these codes or sequences in public areas (e.g., in road traffic) if you have ensured that the application and product settings are safe through testing in self-contained and designated testing environments and circuits.

This ETAS product allows you to influence safety-relevant systems or data (e.g. in motor vehicles, vehicle components and test benches). In the event of a malfunction or a hazardous situation, it must be possible to put the system into a safe state (e.g., emergency stop or emergency operation).

## 1.1 Intended Use

The product was developed and approved for applications in the automotive sector. Only operate the product as per its specifications. If the product is used in any other way, product safety is no longer ensured.

An emulator probe (ETK) is an electronic assembly that is installed in a vehicle control unit (ECU) to exchange data with ECUs.

### Application Areas

- The product is approved for use in the following areas:
  - ECUs
- Do not operate the product in a wet or damp environment.
- Do not operate the product in potentially explosive atmospheres.

### Technical Condition

The product is designed in accordance with state-of-the-art technology. Only operate the product and its accessories if they are in perfect working order. Shut down a damaged product immediately. The product cannot be repaired. Dispose of the product properly. Do not open or alter the product. Only ETAS may make changes to the product.

## 1.2 Classification of Safety Messages

The safety messages used here warn of dangers that can lead to personal injury or damage to property.:



### DANGER

DANGER indicates a hazardous situation that, if not avoided, will result in death or serious injury.



### WARNING

WARNING indicates a hazardous situation that, if not avoided, could result in death or serious injury.



### CAUTION

CAUTION indicates a hazardous situation that, if not avoided, could result in minor or moderate injury.



**NOTICE**

NOTICE indicates a situation that, if not avoided, could result in damage to property.

## 1.3 Safety Information

### 1.3.1 Assembly

The product must only be removed from the ESD packaging and installed in a workplace that is protected against static discharges.

Only install, connect, disconnect, and cable ETAS products and components when they are de-energized.

When installing the product, make sure that the fastening elements do not damage the product's printed circuit board or cause a short circuit.

### Installation Location

**NOTICE**

**Damage to the electronics due to potential equalization**

The cables' shield may be connected to the housing, the ground or the ground for the product's power supply. If there are different ground potentials in the test setup, equalizing currents can flow between the products via the cables' shield.

Take account of different electric potentials in your test setup and take appropriate measures to prevent equalizing currents.

### 1.3.2 Operation

Only operate the product with the latest firmware. You can find information about updating the firmware in the user guide.

If the firmware update is not completed successfully, try it again. If a new firmware update is not possible and the product is not functional, send the product to ETAS.

### 1.3.3 Electrical Connection

#### Electrical Safety and Power Supply

- Only connect the product to electric circuits with safety extra-low voltage in accordance with IEC 61140 (devices of class III) within the voltage limits for accessible parts as per IEC 61010-1.
- Comply with the connection and setting values (see "Technical Data" on page 40).
- The power supply for the product must be safely disconnected from the mains power. For example, use a car battery or a suitable lab power supply.
- Only use lab power supplies with dual protection for the supply network (with double/reinforced insulation (DI/RI)).
- The power supply must be suitable for use according to the ambient conditions for the product.

- It is possible to discharge the vehicle battery in regular operation and long standby operation.
- Central load-dump protection is required for operation.

### Connection to the power supply



#### **DANGER**

##### **Undefined vehicle behavior due to an ECU reset**

If the external power supply to the ETK is interrupted (e.g. cut, disconnected, etc.), this may lead to the ECU being reset.

- Connect the internal power supply of the ECU to the ETK in addition to the external power supply.
- If this is not possible, ensure that the external power supply to the ETK is not interrupted during operation.



#### **WARNING**

##### **Risk to life from electric shock**

If an unsuitable power supply is used, this may generate a hazardous electrical voltage.

- Use a power supply that is permitted for the product.

- Ensure that the connections of the power supply are easily accessible.

### De-energizing the product

1. Disconnect the product from the power supply in one of the following ways:
  - Switch off the laboratory power supply for the test setup.
  - Disconnect the test setup's connection to the vehicle battery.
  - Remove the power cord.
2. Remove all cables from the product.

## 1.3.4 Cables and Accessories

### Cables

- Only use ETAS cables, cables recommended by ETAS or other cables certified for the application.
- Route the cables such that they are protected against abrasion, damage, deformation and kinking.
- Do not place any objects on the cables.
- Do not use any damaged cables.
- The connector and connection must not be dirty.
- The connector and connection must be compatible.
- Correctly align the connector with the connection.
- Do not connect the connector and connection by force.

## Accessories

Use ETAS accessories, accessories recommended by ETAS or other accessories certified for the application. For detailed information about accessories, see "Cables and Accessories" on page 56.

### 1.3.5 Transport

- Only transport and store the product in ESD packaging.
- Only transport the product individually.
- Do not transport the product by the connected cables.

### 1.3.6 Maintenance







The product is maintenance-free.

## Cleaning

- Only clean the product when it is de-energized.
- Make sure that no moisture enters the product.
- Carefully vacuum off dust particles and loose foreign bodies.

## 1.4 Identifications on the Product

The following symbols are used for identifications of the product:

Symbol	Description
	The User Guide must be read prior to the startup of the product!
	Symbol for WEEE, see chapter 1.5 on page 12
	Symbol for CE conformity, see chapter 1.6.1 on page 12
	UKCA conformity symbol (Great Britain), see chapter 1.6.2 on page 12)
	Symbol for China RoHS, see chapter 1.7.2 on page 13
	Symbol for electrostatic sensitive components
XETK-S14.0A	Product designation (example)
F 00K 110 722	Order number of the product (example)
SN: yyxxxxx	Serial number (7-digit)
XXXX/YY	Product version
ZZZZ	Year of manufacture
ETAS GmbH,...	Manufacturer's address



**NOTE**

For symbols and product information one or several adhesive labels can be used.

## 1.5 Taking the Product Back and Recycling

The European Union has passed a directive called Waste Electrical and Electronic Equipment, or WEEE for short, to ensure that systems are setup throughout the EU for the collection, treating and recycling of electronic waste.

This ensures that the devices are recycled in a resource-saving way representing no danger to health or the environment.



**Fig. 1-1** WEEE-Symbol

The WEEE symbol (see Fig. 1-1 on page 12) on the product or its packaging shows that the product must not be disposed of as residual garbage.

The user is obliged to collect the old devices separately and return them to the WEEE take-back system for recycling. The WEEE directive concerns all ETAS devices but not external cables or batteries.

For more information on the ETAS GmbH Recycling software, contact the ETAS sales and service locations.

## 1.6 Declaration of Conformity

### 1.6.1 CE Declaration of Conformity (European Union)

With the CE mark attached to the product or its packaging, ETAS confirms that the product corresponds to the applicable product-specific European Directives. The CE Declaration of Conformity for the product is available upon request.

### 1.6.2 UKCA Declaration of Conformity (Great Britain)

With the UKCA mark attached to the product or its packaging, ETAS confirms that the product corresponds to the product-specific, applicable standards and directives of Great Britain. The UKCA declaration of conformity for the product is available on request.

## 1.7 RoHS Conformity

### 1.7.1 European Union

The EU Directive 2011/65/EU limits the use of certain dangerous materials for electrical and electronic devices (RoHS conformity).

This product does not contain any of the restricted substances specified in the EU Directive 2011/65/EU or exceeds the maximum concentrations stipulated therein. For individual electronic components used in our products, there are currently no equivalent alternative substances, which is why we make use of the exceptions 6B, 7A, and 7C-I in Annex III of this Directive.

ETAS confirms that the product corresponds to this directive which is applicable in the European Union.

### 1.7.2 People's Republic of China

ETAS confirms that the product meets the product-specific applicable guidelines of the China RoHS (Management Methods for Controlling Pollution. Caused by Electronic Information Products Regulation) applicable in China with the China RoHS marking affixed to the product or its packaging.

## 1.8 Declarable Substances

### European Union

Some products from ETAS GmbH (e.g. modules, boards, cables) use components with substances that are subject to declaration in accordance with the REACH regulation (EU) no.1907/2006.

Detailed information is located in the ETAS download center in the customer information "REACH Declaration" ([www.etas.com/Reach](http://www.etas.com/Reach)). This information is continuously being updated.

## 1.9 Use of Open Source Software

The product uses Open Source Software (OSS). This software is installed in the product at the time of delivery and does not have to be installed or updated by the user. Reference shall be made to the use of the software in order to fulfill OSS licensing terms. Additional information is available in the document "OSS Attributions List" at the ETAS website ([www.etas.com](http://www.etas.com)).

## 2 Introduction

This chapter contains information about the following topics:

- Applications..... 14
- Features ..... 14

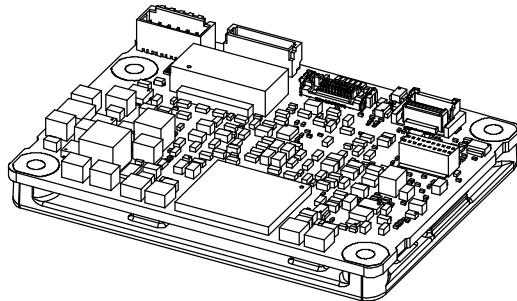
### 2.1 Applications

The FETK-T5.0A is an emulator probe for the NXP S32 Family microcontroller. It is a serial FETK designed for use with the JTAG interface and Aurora Trace interface.



#### NOTE

For supported NXP S32 Family microcontrollers, refer to chapter 7.1.3 on page 41.



**Fig. 2-1** FETK-T5.0A

	FETK-T5.0A
ECU JTAG interface connector	20 pin FCI
ECU Aurora interface connector	20 pin SAMTEC
Power supply connector	6 pin MOLEX
Pinless triggering	Yes
Timer triggering	Yes
Trace Trigger By Value	Yes
Trace Trigger By Reference	No

To access the ECU the FETK-T5.0A has to be connected via ES89x modules. The system can be used for high-speed Measurement, Calibration and ECU flash programming. Support of high-speed and high band width applications e.g. functional prototyping - bypass depends on the functionality of the connected modules.

### 2.2 Features

#### 2.2.1 General

- Enables highest possible data throughput by utilizing the microcontroller "TRACE" interface e.g. Aurora for measurement purposes and the debug interface for configuration and prototyping
- Gigabit Ethernet Interface:
  - Connection to PC via ES89x modules

- Latency optimized proprietary Ethernet protocol for FETKs to ES89x
- Supports a variety of standard applications
- Calibration tool access performed via the microcontroller JTAG interface
  - 3.3V JTAG output levels, 5.0V tolerant JTAG input
  - Configurable JTAG interface clock speed: 20 and 40 MHz
- Permanent storage of configuration
- Third party MC-tool support via ES89x module possible

### 2.2.2 Measurement

- Fast measurements: ECU raster not faster than 15  $\mu$ s



#### NOTE

FETK-T5.0A supports also trace-based measurement. The supported controllers have the ARM trace modules ETM. Trace-based measurement requires additional measures in the ECU SW. Please contact ETAS for details

- Supports “turnkey mechanism” - measurement start immediately after “Ignition on” and proceed measurement after ECU reset (only if serial debug interface is used for measurement)
- Pinless ECU handshake and trigger mechanism
- Hook-based (DISTAB) and hook-less measurement approaches

### 2.2.3 Calibration

- Concurrent use of calibration and measurement performed via microcontroller



#### NOTE

The microcontroller has no dedicated overlay RAM and no internal flash. Please contact ETAS regarding calibration implementation

- Working Page & Reference Page (two-page concept) realized by usage of internal RAM. There is no dedicated overlay RAM
- Single page calibration
- Direct access to parameters, curves, and maps in internal RAM
- Microcontroller capability of external Flash emulation can be used
- Supports “Start on Any Page”
- Supports special cold start mechanism (“Calibration Wake Up”):
  - Calibration Wake Up: Wake up mechanism to wake up the power supply of the ECU via the Calibration Wake up pin
  - Pull CalWakeUp until Startup Handshake: duration of the Wake up mechanism is configurable

#### ECU flash Programming via FETK

- Using microcontroller debug interface, ECU software support not necessary

- Braindead flashing under ProF control

#### 2.2.4 Further Characteristics

- "ETK Tools" update to support ETAS software tools (INCA, XCT)
- Mounting the FETK-T5.0A via heat spreader directly to the ECU housing is recommended
- Heat distribution
- Temperature range suitable for automotive application

For more technical data on the FETK-T5.0A consult the chapter "Technical Data" on page 40.



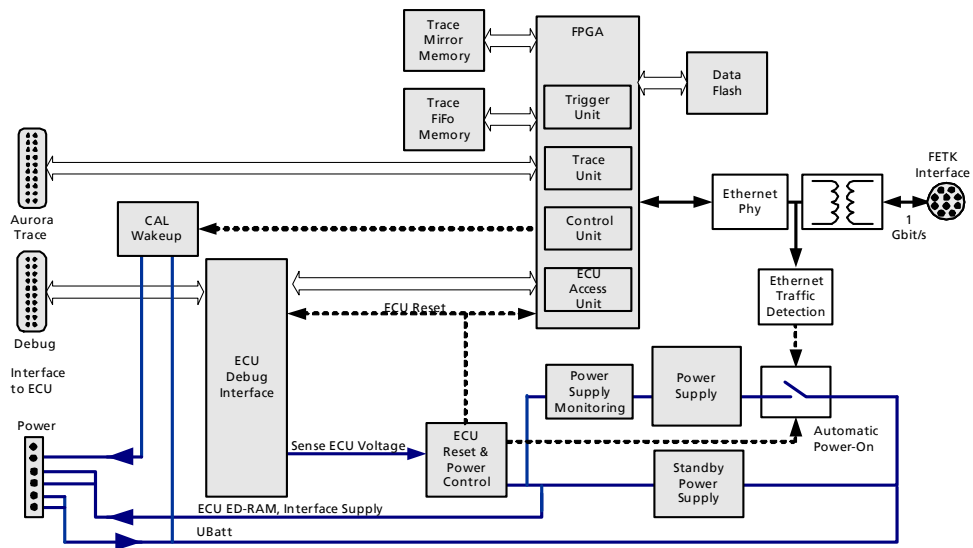
### 3 Hardware Description

This chapter contains information about the following topics:

- Architecture ..... 17
- ECU Interface ..... 18
- FETK Ethernet Interface ..... 19
- Power Supply ..... 20
- ECU Voltage Supervisor ..... 20
- Status LEDs ..... 21
- Data Access ..... 22
- JTAG Interface ..... 24
- Trace Interface ..... 24
- Trigger Modes ..... 25
- Startup Handshake ..... 27
- Reset ..... 27
- Pull CalWakeUp until Startup Handshake ..... 27

#### 3.1 Architecture

Fig. 3-1 shows the block diagram of the FETK-T5.0A



**Fig. 3-1** FETK-T5.0A Architecture

While the microcontroller accesses the program data (not the program code) out of the data memory provided by the microcontroller, the content of the data emulation memory can be measured by the calibration and development system through the FETK-T5.0A interface.

This process enables adjustments of parameters, characteristic lines and maps through the calibration and development system.

Using a trace interface, the FETK-T5.0A can acquire measurement data and send the measured data to the PC.

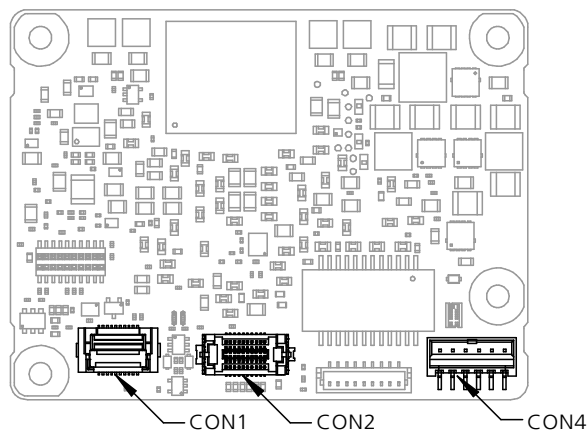
The 1000 Mbit/s Ethernet interface provides communication with the ES89x module.

FETK Connector	Description
CON1	ECU interface (JTAG)
CON2	ECU interface (Trace)
CON3	Ethernet interface (ES89x module)
CON4	Power supply

### 3.2 ECU Interface

The FETK-T5.0A is connected via connectors CON1, CON2, and CON4 to the ECU with three adapter cables (refer to Fig. 3-2 on page 18). The pin definition depends on the application and the microcontroller type. In general the ECU interface consists of

- 1 ECU voltage line, which is not used for FETK power supply, but only for detection of the ECU status, therefore the power consumption on this line is negligible (refer to chapter 3.4 on page 20)
- 1 reset line which allows the FETK to control the system reset of the ECU
- 1 reset line which allows the FETK to monitor the system reset of the ECU
- 5 debug line interfaces for the communication between the FETK-T5.0A and the microcontroller
- 1 differential clock line (100 MHz)
- 4 differential trace lanes
- 1 Watchdog disable line
- 1 ground line.



**Fig. 3-2** Location of the ECU Interfaces JTAG (CON1) and Trace (CON2)

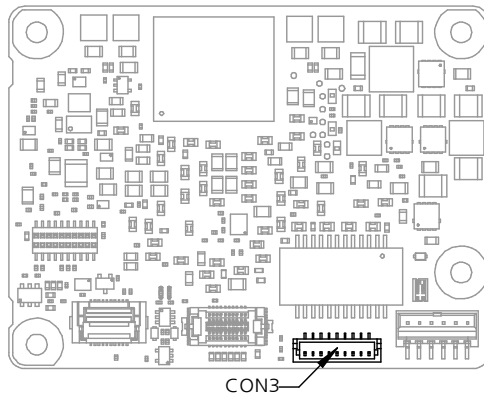
### 3.3 FETK Ethernet Interface

The FETK Ethernet interface utilizes a proprietary protocol. It has to be connected to the PC via a ES89x ECU Interface Module at CON3 (refer to Fig. 3-3).



#### NOTE

The FETK Ethernet interface utilizes a proprietary Ethernet protocol and is compatible only with the Gigabit Ethernet interfaces of the ES89x ECU Interface Module.



**Fig. 3-3** Location of the Ethernet Interface Connector (CON3)

### 3.4 Power Supply

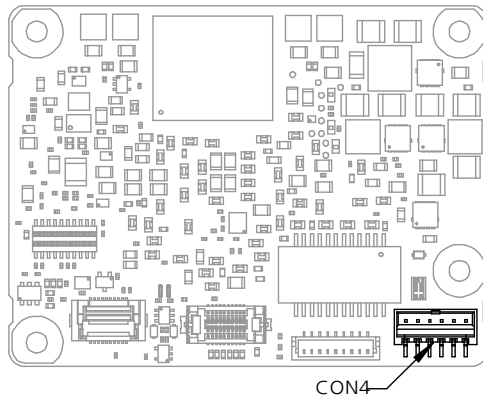
The FETK-T5.0A requires a permanent power supply. It is typically powered directly from the car battery. The input voltage may vary between 6.0 V and 36 V. In case of higher input voltages to the FETK, additional voltage protection is required.

The FETK is suitable for 12 V and 24 V systems. In 24 V systems the load dump capability is reduced.

The FETK-T5.0A will also accept voltage drops down to 3 V, for a maximum duration of 15 ms (for additional details of low voltage operation, see ISO standard 16750).

From the input battery voltage, switch-mode power supplies provide all necessary voltages on the FETK-T5.0A. The power supply of the ECU is not affected by the FETK-T5.0A. An automatic switch ensures that the power supply of the FETK-T5.0A is automatically switched on and off when the FETK enters and leaves its standby (sleep) mode.

The FETK-T5.0A is supplied with power through the connector CON4.



**Fig. 3-4** Location of the Power Supply Connector (CON4)

### 3.5 ECU Voltage Supervisor

The ECU voltage (VDDP) is monitored by the FETK to recognize whether the ECU is switched on or off.

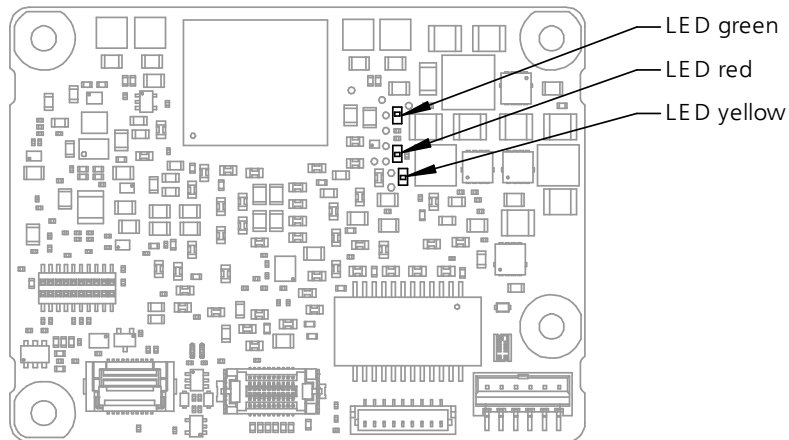


#### NOTE

The FETK-T5.0A only allows switching between reference page and working page if there is a valid reference page and working page in the RAM of the micro-controller. There is no standby powering of the RAMs.

### 3.6 Status LEDs

There are three LEDs displaying the operating status of the FETK-T5.0A (Fig. 3-5 on page 21).



**Fig. 3-5** Status LEDs

LED	State	Definition
Red	On	FETK-T5.0A is supplied with power and active (i.e. the ECU is switched on or the ETAS calibration and development system is connected and ready to communicate with the FETK-T5.0A) <sup>1</sup>
Green	Off	Working Page contains data and is accessible from INCA
	Flashing	FETK-T5.0A is in boot configuration mode: - measurement and calibration are not possible, - FETK-T5.0A update with HSP is required
	On	Power supply has dropped under selected threshold: - data retention of the calibration data manager in the ECU is no longer ensured - as soon as the FETK-T5.0A switches on again, the ECU switches to the Reference Page. Green LED stays on until the calibration and development system downloads data into the calibration data memory. Otherwise switching to the Working Page is not possible.
Yellow	Off	FETK-T5.0A: no link to calibration system established
	On	1000 Mbit/s communication to calibration system established

## 3.7 Data Access

### 3.7.1 Calibration Data Access

The FETK-T5.0A is a serial FETK using JTAG and a trace interface as the primary microcontroller interface. Typical of all serial ETKs, XETKs and FETKs, the RAM used for data emulation and data measurement is not accessible by the FETK until the microcontroller is powered up and the startup handshake is performed.

Serial FETKs use the ETAS two-page concept, consisting of both a Reference and a Working page.

The Reference Page is located in the ECU flash and can not be modified by a simple write access. All changes to the Reference Page must be done via Flash programming.

The Working Page is located within the microcontroller's ED RAM. The Working Page may be a portion of or the entire size of the ED RAM. The ED RAM used for the emulation of calibration data must not be used by the ECU software directly as general purpose RAM. It is recommended that the ED RAM is permanently powered by the FETK-T5.0A or ECU and shall not be reset by the ECU, if the FETK-T5.0A signals a permanently powering of the ED RAM during handshake.

The FETK / INCA has the complete control over the RAM used as Working Page and its contents. When enabling data emulation, the FETK establishes a basic startup configuration of the data in the Working Page by copying the corresponding data in the Flash to the emulation space.

To enable calibration, the Working Page must be activated. The process of switching from the Reference Page to the Working Page and vice versa is known as page switching.

The FETK-T5.0A supports Protocol Based page switching for all supported microcontrollers. Page switching is done in microcontroller software by switching the overlay memory on (Working Page) and off (Reference Page) using microcontroller overlay registers. The FETK-T5.0A does not directly control the microcontroller overlay registers. Instead, the FETK-T5.0A and microcontroller software use a simple communication method with a shared mailbox in RAM. The FETK-T5.0A uses this mailbox to request and monitor page switching; the microcontroller software is responsible to service this mailbox and perform the page switches. Using an overlay modification description, also in RAM, the FETK-T5.0A provides the necessary information.

The FETK-T5.0A can access both the Reference Page and the Working Page, regardless of which is active from the microcontroller's point of view.

Another important restriction is that no access to the memory is possible, while the ECU is not running. To enable a cold start measurement in spite of this restriction, the cold start measurement procedure is defined to give the user the feeling of a parallel FETK.

### 3.7.2 Measurement Data Access

The FETK-T5.0A is a serial FETK, so all data to be measured is located in the ECU memory. It can be read out by the FETK-T5.0A in two ways:

- Trace measurement using the Aurora trace interface
- Read accesses using the JTAG interface

#### Trace Measurement

The microcontroller ability to send trace messages over the Aurora interface is used to forward any write access to measurement data to the FETK-T5.0A. The FETK-T5.0A combines the processing of this data trace messages with an initial direct read of the configured measurement data to an always up to date mirror of the measurement data in the ECU.

The current values will be sent from the FETK to INCA every time the ECU software issues the corresponding trace trigger. For details on trace trigger (refer to chapter 3.10.2 on page 25). The FETK-T5.0A does the complete configuration of the microcontroller for trace-based measurement. No ECU software is required for the configuration.

For limitations regarding trace-based measurement see note in chapter 2.2.2 on page 15.

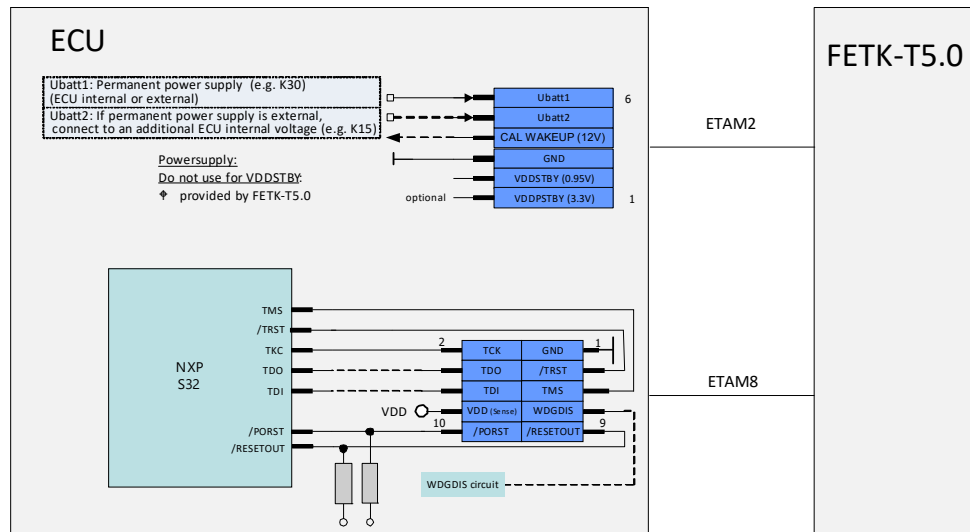
#### Direct Measurement

The FETK-T5.0A reads the measurement data through the JTAG interface.

The read action will be executed by the FETK-T5.0A, when it is invoked by a hardware trigger (refer chapter 3.10.4 on page 26).

Due to the throughput limitations of the JTAG interface, this method is not as suitable for high-speed measurement as the Trace Measurement.

### 3.8 JTAG Interface



**Fig. 3-6** Equivalent Circuitry of the ECU JTAG Interface (ECU)

The FETK-T5.0A operates over the JTAG interface. The FETK-T5.0A hardware incorporates 22 Ohm series termination resistors for the output ports TCK, TDI, TMS and /TRST.

Similar termination should be considered on the ECU board - depending both on the layout and on the JTAG interface clock rate.

### 3.9 Trace Interface

To transfer all data and address information of all microcontroller CPUs traditional trace-based measurement requires for the device a high-speed trace interface. The Emulator Probe for NXP S32 Family reduces the net data rate at the trace port into the range of MByte/s by collecting only relevant data at given points of time from mirrored RAMs of the device internal RAMs.

The FETK-T5.0A supports the Aurora Trace Interface.



## 3.10 Trigger Modes

### 3.10.1 Overview

The FETK-T5.0A supports the following trigger modes:

- Trace triggering by value  
The trigger mode "Trace Triggering" uses defined values written into a defined Trace-address for triggering (see also chapter 3.10.2 on page 25).
- Pinless triggering  
The trigger mode "Pinless Triggering" depends from the microcontroller's target:
  - S32Z uses internal TRIG registers and
  - S32G uses RAM based triggering.  
(see also chapter 3.10.3 on page 26).
- Timer triggering  
The trigger mode "Timer Triggering" uses four internal timers of the FETK for triggering (see also chapter "Timer Triggering" on page 26).

### 3.10.2 Triggering via Trace Interface

The FETK-T5.0A provides support for up to 96 data trace triggers with DTS and 256 with RAM. The trace triggers are defined within a section of RAM covered by a trace window. Both the trace window and trace triggers are defined in the FETK's configuration and/or A2L file. A write by the microcontroller software to a trace trigger location causes a trace trigger.

The trace trigger events to the FETK-T5.0A are synchronous to the microcontroller software. Variables assigned to a measurement raster using a trace trigger are acquired using the trace interface, not via JTAG.

The FETK-T5.0A supports value based data trace trigger:

- triggers for different raster/events have same address, but use different values
- up to 96 value based trace trigger are supported.



#### NOTE

It is not possible to use the FETK-T5.0A configured with trace triggers and a debugger with program / data trace simultaneously.

### 3.10.3 Pinless Triggering

#### FETK Trigger Generation

Microcontroller variant S32Z:

- To generate triggers, the ECU software sets bits by writing the associated trigger index in the "DTS\_SEMAPHORE/DTS\_SEMAPHORE\_B/DTS\_SEMAPHORE\_C" registers.



#### NOTE

The selective setting of trigger bits is accomplished in hardware by the microcontroller and does not require a Read-Modify-Write sequence by the ECU software.

Microcontroller variant S32G:

- RAM based triggering is used.

#### DTS\_SEMAPHORE Register

Each bit of the "DTS\_SEMAPHORE" register corresponds to an FETK-T5.0A hardware trigger. Within the FETK's configuration and/or A2L file, bit 0 corresponds to hardware trigger 1 and bit 31 corresponds to hardware trigger 32.

#### DTS\_SEMAPHORE\_B Register

Each bit of the "DTS\_SEMAPHORE\_B" register corresponds to an FETK-T5.0A hardware trigger. Within the FETK's configuration and/or A2L file, bit 0 corresponds to hardware trigger 33 and bit 31 corresponds to hardware trigger 64.

#### DTS\_SEMAPHORE\_C Register

Each bit of the "DTS\_SEMAPHORE\_C" register corresponds to an FETK-T5.0A hardware trigger. Within the FETK's configuration and/or A2L file, bit 0 corresponds to hardware trigger 65 and bit 31 corresponds to hardware trigger 96.

#### Initialization

The FETK-T5.0A periodically polls (reads) the "DTS\_SEMAPHORE/DTS\_SEMAPHORE\_B/DTS\_SEMAPHORE\_C" register via JTAG. The polling rate is configurable, with 50  $\mu$ s default. The FETK-T5.0A then starts acquisition of appropriate measurement data based on which bits of the register are set.

Active bits in "DTS\_SEMAPHORE/DTS\_SEMAPHORE\_B/DTS\_SEMAPHORE\_C" are automatically cleared by the microcontroller when the register is read by FETK.

### 3.10.4 Timer Triggering

The trigger mode "Timer Triggering" uses four internal timers of the FETK-T5.0A for triggering. A fixed configurable period is used for triggering.

The time intervals between trigger events are in accordance with the configured timer values. These values and their resolution have to be defined in the A2L file.

Available settings are:

- Minimum time interval 100  $\mu$ s
- Maximum period duration 1 s
- Timer resolution 1  $\mu$ s

The timers work in an asynchronous manner to the ECU.

### 3.11 Startup Handshake

The ECU must ensure that all memory ECC initializations have been completed prior to the startup handshake. After the startup handshake and measurement is enabled, the FETK is waiting for triggers from the ECU software.

Generating the startup:

- microcontroller variant S32Z: Dedicated handshake registers are used.
- microcontroller variant S32G: RAM based handshake is used.

### 3.12 Reset

The requirement for the FETK-T5.0A reset mechanism is to ensure that power-up and power-down behavior of ECU is clean and smooth. The FETK-T5.0A generates a /PORST on user request, only. In case of a reconfiguration of the FETK-T5.0A INCA asks the user if a reset shall be performed.

The signals /PORST and /RESETOUT of the microcontroller are used by the FETK-T5.0A to detect when the ECU is in reset.



#### NOTE

The reset signal /PORST can be hold or pulled low while the FETK-T5.0A is booting depending on the use of the adapter ETAM8A or the adapter ETAM8B (see chapter "ETAM8 Adapter" on page 67). The FETK-T5.0A has to be configured in the XCT tool according to the needed reset signal characteristic during FETK-T5.0A standby.

The FETK-T5.0A senses the switched ECU power supply. This allows it to detect when the ECU is off and forward this information to INCA. In addition, it allows the FETK to enter the power save mode with the calibration system unplugged.

### 3.13 Pull CalWakeUp until Startup Handshake

The FETK has the ability to wake up the ECU by applying voltage to the CalWakeUp pin of the ECU connector. This allows the FETK to configure a measurement while the ECU is off.

When waking up the ECU via the CalWakeUp pin, it can be configured if the pin is driven high until the microcontroller core voltage (VDDP) is high or if the pin should be driven high until the startup handshake between ECU and FETK is complete.

## 4 Installation

This chapter contains information about the following topics:

- Mounting the FETK-T5.0A into the ECU Housing ..... 28
- Connection to the ECU. .... 31
- Wiring ..... 33
- Power Supply ..... 33

### 4.1 Mounting the FETK-T5.0A into the ECU Housing

**NOTICE**

**Damage to the electronics due to potential equalization**

The cables' shield may be connected to the housing, the ground or the ground for the product's power supply. If there are different ground potentials in the test setup, equalizing currents can flow between the products via the cables' shield. Take account of different electric potentials in your test setup and take appropriate measures to prevent equalizing currents.

#### 4.1.1 Thermal Connection Requirements

To ensure proper operation of the FETK-T5.0A over the specified temperature range, the FETK-T5.0A must be mounted to the ECU metal housing. This enables thermal dissipation of the electronic components used on the FETK-T5.0A to the ECU housing.

**i NOTE**

To avoid overheating of the FETK-T5.0A the connection to the ECU housing following requirements for thermal conductivity must be met:

- ECU housing thermal conductivity at the FETK-T5.0A mounting position:  $> 2.5 \text{ W/(m} \cdot \text{K)}$ , guaranteed by size and material of the ECU housing and
- heat conductive paste thermal conductivity:  $> 0.75 \text{ W/(m} \cdot \text{K)}$ .

**i NOTE**

If the value of ECU housing thermal conductivity cannot be achieved, additional cooling structures, e.g. heat sinks, should be applied.

For additional details on thermal dissipation, see chapter "Environmental Conditions" on page 42.

#### 4.1.2 Mounting Material

To mount the FETK-T5.0A to the ECU housing several materials are required:

- FETK-T5.0A
- ECU metal housing with machined holes aligning with FETK-T5.0A hole pattern (see chapter "Mechanical Dimensions" on page 54
- Heat conductive paste with a thermal conductivity  $> 0.75 \text{ W/(m} \cdot \text{K)}$
- Four screws M2.5

- cylinder head, countersunk-, self-sealing screw
- length depending on the ECU project:  
(≥ 8 mm + wall thickness ECU housing)
- Four nuts M2.5
- Thread locking fluid
- Screwdriver T8

### 4.1.3 Mounting Steps

To mount the FETK-T5.0A to the ECU housing several mounting steps are required:

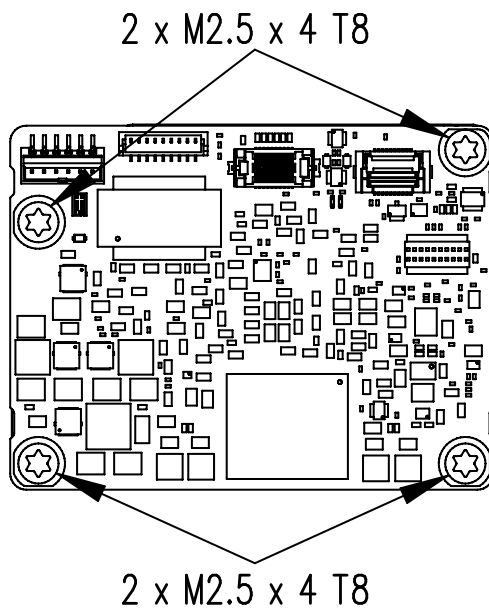
#### Preparing the ECU Housing

1. Drill four holes in the ECU housing.

**i** NOTE

Use the "FETK-T5.0A Dimensions - Top View" on page 54 as a drilling template to prepare the ECU housing with machined holes aligning with FETK-T5.0A hole pattern.

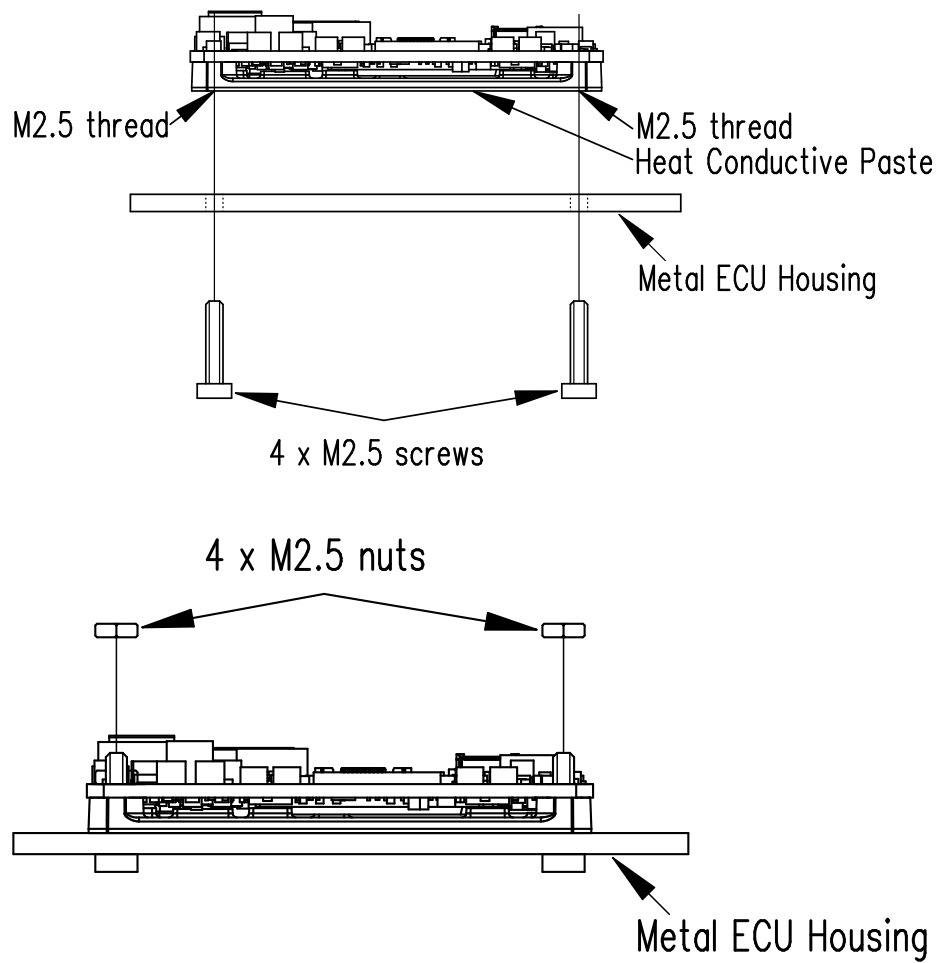
#### Preparing the FETK-T5.0A



**Fig. 4-1** Heatspreader Screws

1. Remove the four screws from the FETK-T5.0A.  
The screws are only a transport lock for the heat spreader.
2. Apply a thin layer of heat conductive paste to the bottom side of the FETK-T5.0A heat spreader.

Attaching the FETK-T5.0A to the ECU Housing



**Fig. 4-2** Attaching the FETK-T5.0A to the ECU

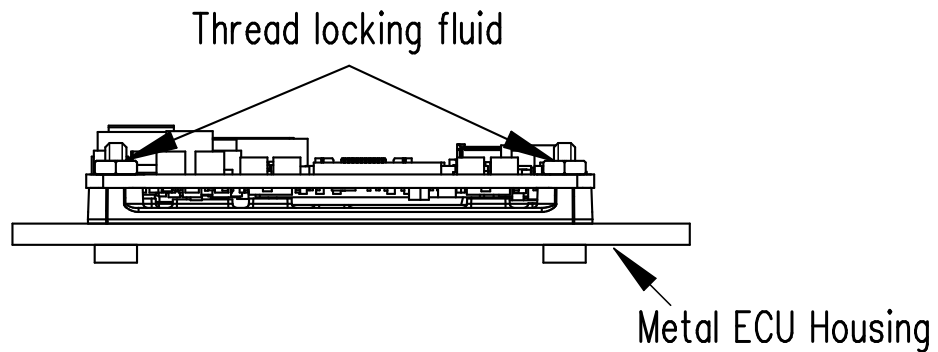
1. Align the threaded drill holes of the FETK-T5.0A to the openings in the ECU housing.
2. Insert the screws into the holes in the ECU housing.
3. Screw the screws into the FETK-T5.0A.

**(i) NOTE**  
 Screw the two parts together without getting them off-thread.

4. Screw the four nuts onto the protruding threaded bolts from above.

**(i) NOTE**  
 Screw the FETK-T5.0A onto the ECU housing using exclusively M2.5 screws and a max. torque of 0.9 Nm.

Locking the nuts



**Fig. 4-3** Thread Locking Fluid

1. Use thread locking fluid to lock the four nuts,  
The FETK-T5.0A and the ECU housing are now connected mechanically.

## 4.2 Connection to the ECU



**NOTE**

When you mount the FETK to the ECU, you must ensure that the screws and washers used will not penetrate the FETK printed circuit board.

For connecting the FETK-T5.0A to the ECU three FETK adapter cables are recommended:

- at CON1 adapter cable ETAM8A or ETAM8B
- at CON2 adapter cable ETAM4
- at CON4 adapter cable ETAM2 or ETAM5

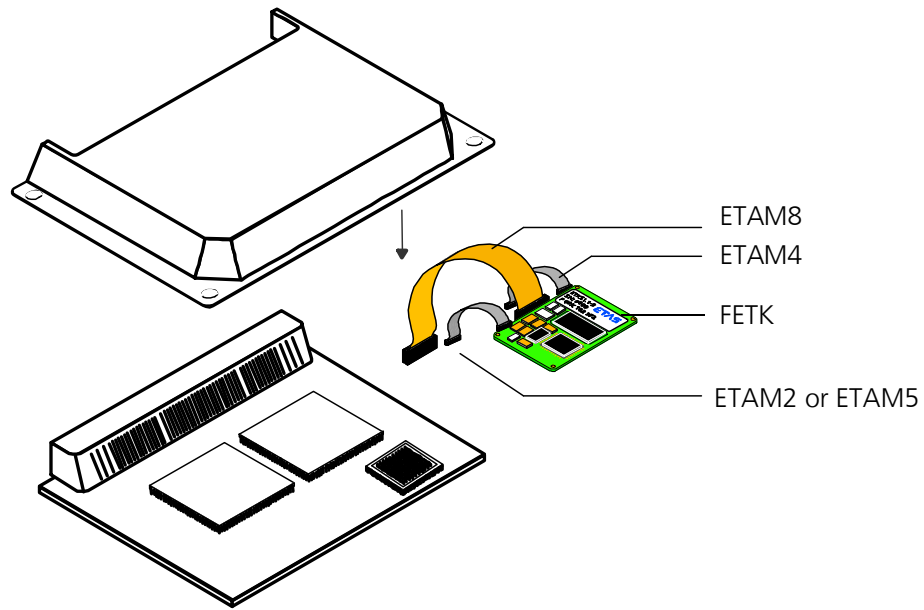


Fig. 4-4 FETK-T5.0A Connection to the ECU

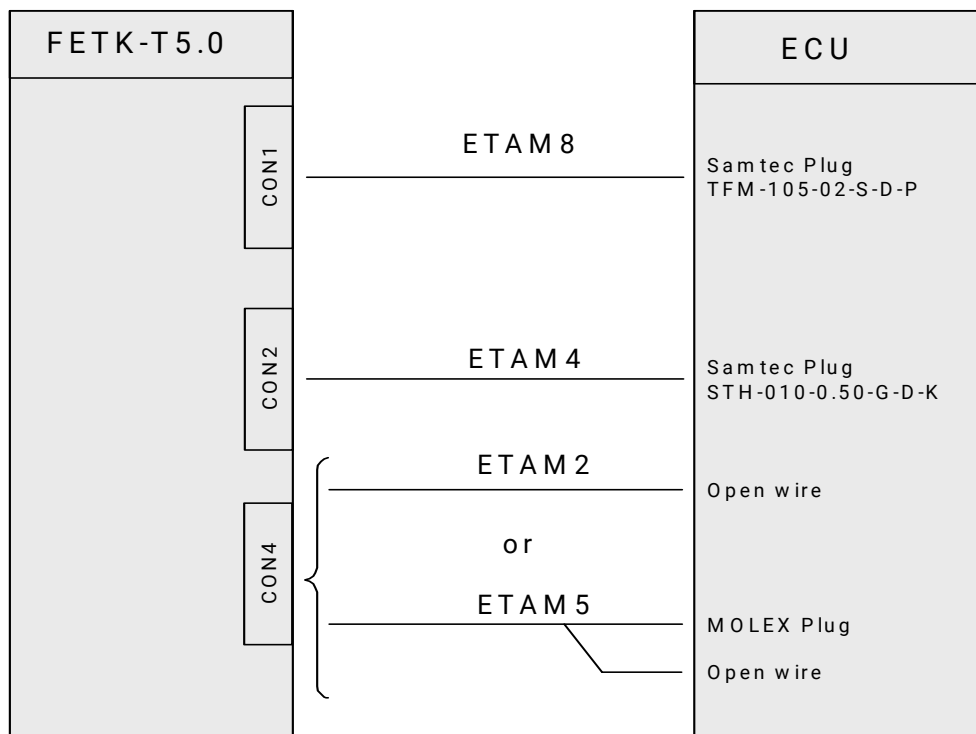
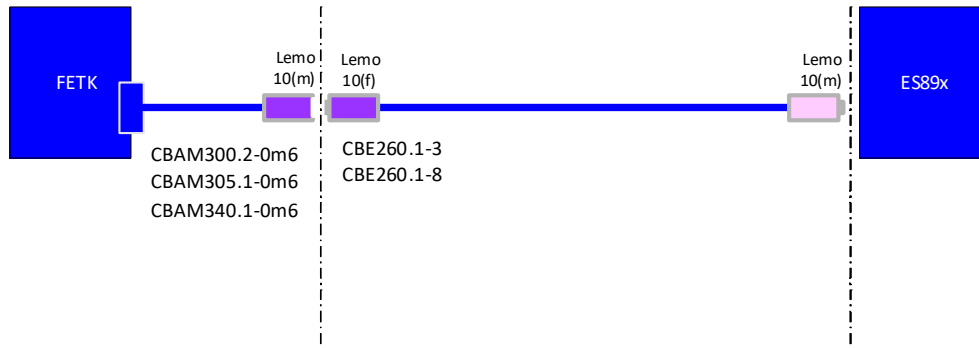


Fig. 4-5 FETK-T5.0A Connection to the ECU



### 4.3 Wiring

#### 4.3.1 FETK Ethernet Interface



**Fig. 4-6** Wiring - FETK-T5.0A Ethernet Interface

The FETK Ethernet interface can be connected to the ES89x ECU and Interface Module.



#### NOTE

The FETK Ethernet interface utilizes a proprietary Ethernet protocol and is compatible only with the Gigabit Ethernet interfaces of the ES89x ECU Interface Module.

### 4.4 Power Supply

The FETK-T5.0A needs a permanent power supply (refer chapter "Power Supply" on page 20).



#### DANGER

##### Undefined vehicle behavior due to an ECU reset

If the external power supply to the ETK is interrupted (e.g. cut, disconnected, etc.), this may lead to the ECU being reset.

- Connect the internal power supply of the ECU to the ETK in addition to the external power supply.
- If this is not possible, ensure that the external power supply to the ETK is not interrupted during operation.



#### WARNING

##### Risk to life from electric shock

If an unsuitable power supply is used, this may generate a hazardous electrical voltage.

- Use a power supply that is permitted for the product.

Permanent Power Supply inside ECU available

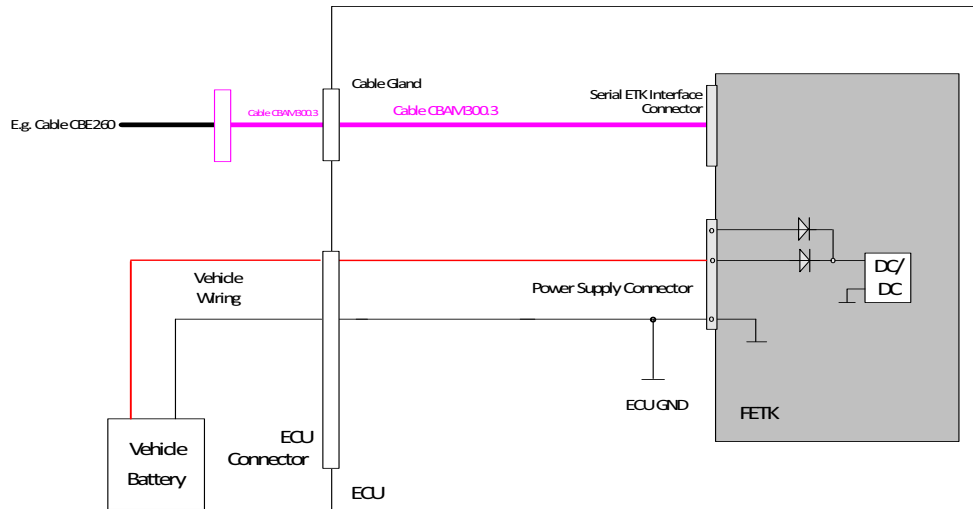


Fig. 4-7 FETK-T5.0A Power Supply wiring with CBAM300.3 Cable

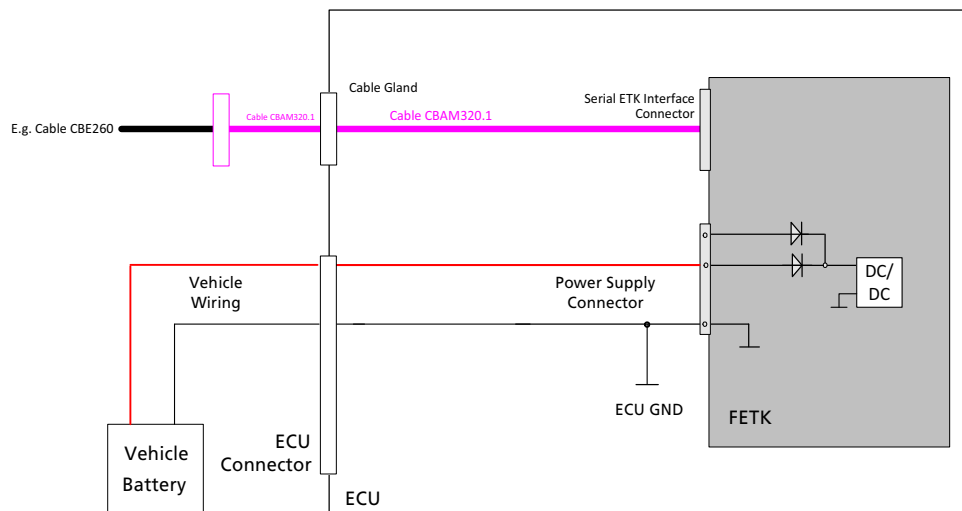
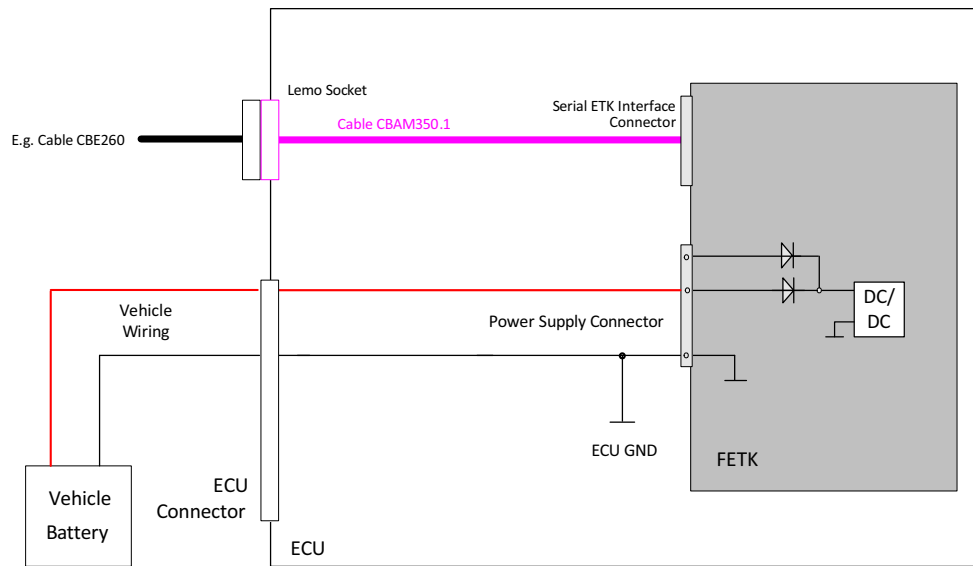
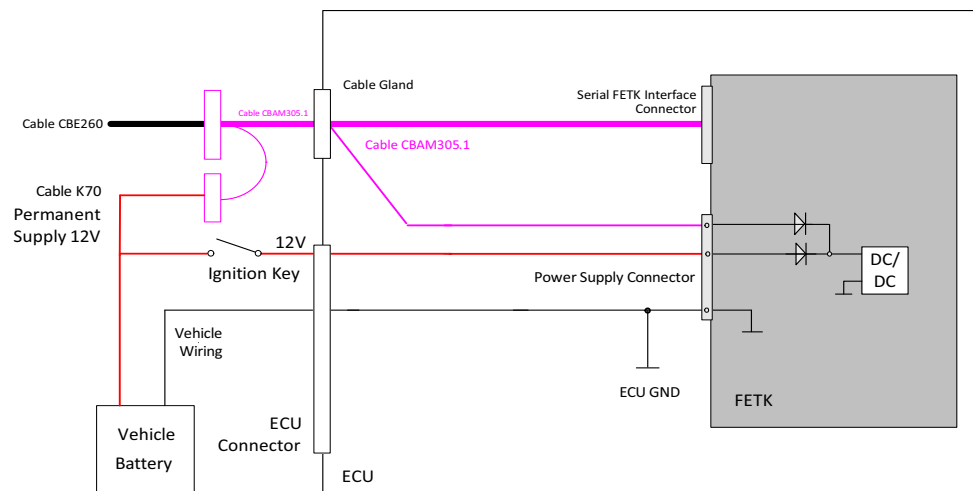


Fig. 4-8 FETK-T5.0A Power Supply wiring with CBAM320.1 Cable



**Fig. 4-9** FETK-T5.0A Power Supply wiring with CBAM350.1 Cable

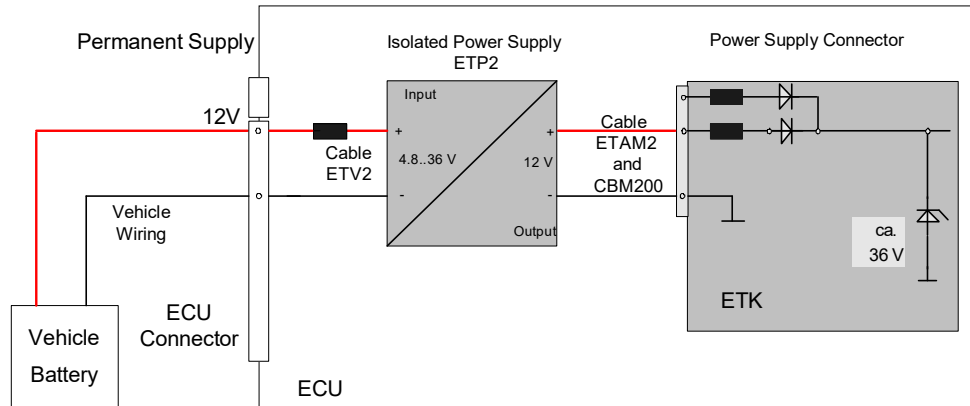
Permanent Power Supply inside ECU not available



**Fig. 4-10** FETK-T5.0A Power Supply wiring with CBAM305.1 Cable

### Isolated Power Supply inside ECU (ETP2)

The FETK-T5.0A does not require a galvanically isolated power supply. For special applications ETAS can offer a isolated power supply unit



**Fig. 4-11** Isolated Power Supply inside ECU

## 5 ETK / XETK / FETK Configuration

This chapter contains information about the following topics:

- Overview ..... 37
- Configuration Parameter ..... 38

### 5.1 Overview

As already mentioned in previous chapters, some project-specific adjustments are necessary. Configuration data is stored permanently.

Generating a valid configuration data set is supported by the XETK Configuration Tool (XCT). The XCT contains information on all available ETKs, XETKs, and FETKs. The user is supported through a graphical interface.

The configuration is done in two steps:

1. Generation of the special address offset for the emulation and measurement data memory.  
The location of data areas, measured data output areas, trigger segment addresses etc. are familiar to the ECU software developer, or can be generated automatically. If an ECU description database (ASAP, ...) with the corresponding input exists, these inputs can be downloaded from this database. If necessary, a plausibility check is performed.
2. Connection of the ETK / XETK / FETK to the ECU.  
The ECU hardware developer defines the connection of the ETK / XETK / FETK to the ECU. The corresponding signals usually have to be adjusted for each microcontroller. All inputs are checked for plausibility, to make sure that a valid configuration is generated.

The XCT can create the following output:

- Direct ETK / XETK / FETK configuration
- Storage of the configuration in a data file
- The corresponding ASAP2 input

The most important outputs are the entries for the ASAP2 file. All A2L definitions necessary for configuring an ETK / XETK / FETK will be created. These are e.g.:

- Overlay Region definitions
- Memory Segment definitions
- ETK / XETK / FETK configuration features
- Raster definitions

If these parameters are entered correctly in the corresponding ECU description file, it guarantees that every time the calibration system is started, the ETK / XETK / FETK is checked for the appropriate configuration.

If necessary, the ETK / XETK / FETK will be configured appropriately to the corresponding project.

## 5.2 Configuration Parameter

The XCT provides support concerning hardware configuration parameters and their possible values.

They are described for the different ETK / XETK / FETK types in the help document of the XCT.

### Starting the XCT help

1. Start XCT.  
The main window of XCT opens.
2. Select in the menu bar **? > Contents**.  
The XCT help window opens.
3. Choose **Reference to User Interface > (X)ETK Hardware Configuration Parameters**.
4. Choose the topic **FETK-T5.0A**.  
The topic **FETK-T5.0A** contains information about the FETK-T5.0A hardware configuration parameters and their possible values.

## 6 Troubleshooting

### 6.1 Problems and Solutions

#### 6.1.1 No communication between the ECU and ETK

**Cause:** No permanent powersupply at the FETK-T5.0A.

It is possible, that if ECU and ETK are switched-on simultaneously, no communication between the ECU and ETK can be established.

**Workaround:** Trigger an ECU reset by application tool.



#### NOTE

The FETK-T5.0A requires a permanent power supply. It is typically powered directly from the car battery. Refer to chapter "Power Supply" on page 33.

## 7 Technical Data

This chapter contains information about the following topics:

- System Requirements ..... 40
- Data Emulation and Measurement Memory ..... 41
- Environmental Conditions ..... 42
- FETK Ethernet Interface ..... 43
- Power Supply ..... 45
- Microcontroller Interface ..... 45
- Test Characteristics ..... 46
- JTAG Timing Characteristics ..... 47
- Aurora Trace Timing Characteristics ..... 47
- Electrical Characteristics ..... 48
- Pin Assignment ..... 50
- Mechanical Dimensions ..... 54

### 7.1 System Requirements

#### 7.1.1 ETAS Compatible Hardware

ETAS Hardware: ES89x ECU Interface Modules

#### 7.1.2 PC with one Ethernet Interface

A PC with one open Ethernet interface (1 Gbit/s) with RJ-45 connection is required to connect the ES89x module.

#### Requirement to ensure successful Initialization of the Module



#### NOTE

It is imperative you disable the function which automatically switches to power-saving mode on your PC network adapter when there is no data traffic on the Ethernet interface!

#### To deactivate the Power saving Mode

Choose in Windows System Control Center / Device Manager / Network Adapter the used network adapter by double-click. Deactivate the "Allow the computer to turn off this device to save power" option in the "Power Management" register. Confirm your configuration.

The manufacturers of network adapter have different names for this function.

Example:

- "Link down Power saving"
- "Allow the computer to turn off this device to save power"



### 7.1.3 Software Requirements

You need following software versions to support the FETK-T5.0A. Operating the FETK-T5.0A with older software versions is not possible.

Micro-controller <sup>1)</sup>	HSP	INCA	ETK Tools	ASCET-RP	INTECRIO
NXP S32Gxxx	V13.4.0	V7.4 SP4	V4.3.4	V6.4.5	V5.0.3
NXP S32Zxxx	V13.4.0	V7.4 SP4	V4.3.4	V6.4.5	V5.0.3
NXP S32Exxx	V13.6.0	V7.4 SP6	V4.3.6	V6.4.5	V5.0.3

<sup>1)</sup> For information, which exact derivate is supported, please contact ETAS

FETK-T5.0A configuration instructions under INCA and HSP are described in the relevant software documentation.

## 7.2 Data Emulation and Measurement Memory

### 7.2.1 Memory for Data Emulation

The FETK-T5.0A uses a portion of or up to the entire size of the internal RAM, to emulate data in the flash. All the handle sizes must be equally sized. Up to 96 handles are supported.

Microcontroller	Max. RAM	Standby powered
NXP S32 Family	Part of the microcontroller memory and depends on the ECU project	No

### 7.2.2 Measurement Data Memory

Item	Characteristics
Location	Measurement data memory can be located in internal RAM when using DISTAB17 hooks.

## Configuration

Item	Characteristics
Configuration	Project-specific configuration for - different microcontrollers or - memory configurations stored in FETK flash
Update	Logic devices updated using HSP software

## 7.2.3 Trace Memory

Item	Characteristics
Trace mirror size	4 MByte (phys.)

## 7.3 Environmental Conditions

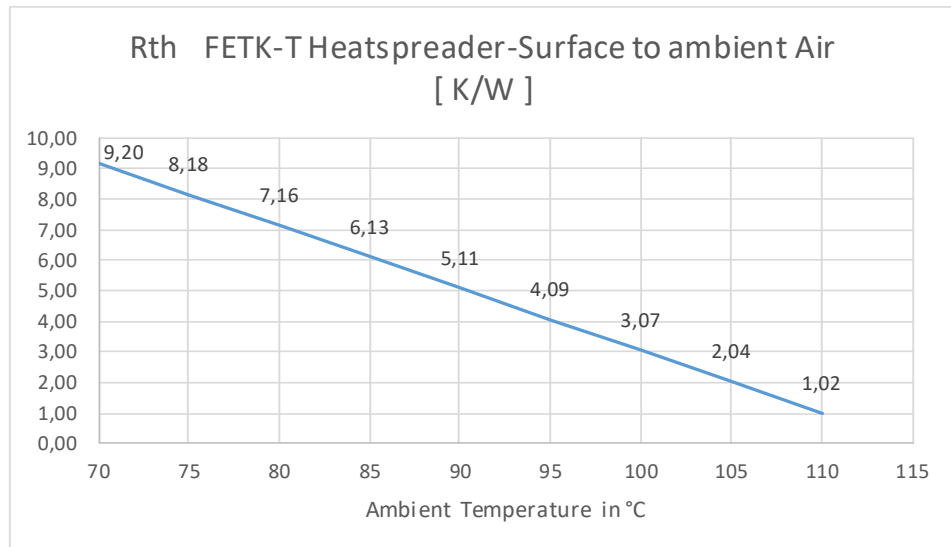
Item	Characteristics
Operating temperature range	- 40 °C to +110 °C / - 40 °F to +230 °F
Storage temperature range (without packaging)	0 °C to +50 °C / 32 °F to +122 °F
Max. relative humidity (non-condensing)	95%
Max. altitude	5000 m / 16400 ft
Degree of contamination (IEC 60664-1, IEC 61010-1)	2
Protection rating (when closed)	Determined by installation in ECU
Overvoltage category (mains supply)	II

Inside the ECU housing the max. temperature is specified with 110 °C / 230 °F, still air. Outside of the ECU the max. ambient temperature is assumed to be 105 °C / 221 °F at 1 m/s airflow. The power dissipation of the FETK-T5.0A will be max. 5.2 Watt.

**NOTE**

It is recommended to mount the FETK-T5.0A via the heat spreader directly to the ECU housing.

R<sub>th</sub> stands for the maximum allowed thermal resistance depending on the ambient air and is measured in [Kelvin/Watt]



**Fig. 7-1** Max. Thermal Resistance from FETK-T5.0A Heatspreader-Surface to Ambient

T <sub>Ambient</sub> [°C]	R <sub>th</sub> FETK-T5.0A Heatspreader-Surface to ambient Air [K/W]
70	9.20
75	8.18
80	7.16
85	6.13
90	5.11
95	4.09
100	3.07
105	2.04
110	1.02

$R_{th} = (125 - 10 - T_{amb}) / 4.89 \text{ K/W}$   
 $T_{jmax} = 125 \text{ °C}$

#### 7.4 FETK Ethernet Interface

Item	Characteristics
Connection	1 Gbit/s Ethernet
Cable length	max. 30 m / 100 ft
Ethernet Interface	DC decoupling Max. Isolation Voltage 60 V DC, according IEC 61010-1 ("Limit values for accessible parts" in normal, dry condition)



**NOTE**

The FETK Ethernet interface utilizes a proprietary Ethernet protocol and is compatible only with the Gigabit Ethernet interfaces of the ES89x ECU Interface Module.

## 7.5 Power Supply

Parameter	Symbol	Condition	Min	Typ	Max	Unit
Permanent power supply	$U_{Batt}$	only for 12V vehicle <sup>1)</sup>	6.0	12	36	V
[all values +/-0%]						
Cranking voltage	$U_{Batt}$	< 3 seconds	3			V
Deep standby current	$I_{STBY1}$	$U_{Batt} = 12\text{ V}$ ; ECU off; no load from ECU; $T = 20\text{ °C}$	1	3	5	mA
Standby current	$I_{STBY2}$	$U_{Batt} = 12\text{ V}$ ; ECU off; no load from ECU; $T = 20\text{ °C}$	50	78	110	mA
Operating current	$I_{Batt}$	$U_{Batt} = 12\text{ V}$ ; no load from ECU; $T = 20\text{ °C}$	150	210	320	mA
Power dissipation	$P_{Batt}$	$U_{Batt} = 12\text{ V}$ ; $T = 20\text{ °C}$	2.16	2.52	3.84	W
Fuse in the ETK Ubatt supply line. Only required if the power supply or ECU is not protected accordingly.			MINI vehicle blade-type fuse, fast-acting, 2 A 58V DC, e.g. Littelfuse 0997002.WXN			

<sup>1)</sup> The FETK-T5.0A implements reverse voltage protection in the same range and may be used only with central load dump protection.  
24 V vehicles require  $U_{Batt}$  disturbing pulse reduction to 12 V vehicle system.  
12 V vehicles don't require special disturbing pulse reductions.

**NOTE**

The FETK-T5.0A will accept permanent power supply voltage dips (for additional details of 3 V low voltage operation, see ISO standard 16750).

## 7.6 Microcontroller Interface

	Symbol	Condition	Min	Typ	Max	Unit
ECU Standby RAM Output Voltage	VDDSTBY	do not use				V
VDDPSTBY Output Voltage	VDDP-STBY	max. 80 mA load	3.14	3.3	3.46	V
Cal_Wakeup Output Voltage	CAL_WAK EUP	$U_{Batt} = 6 - 32\text{ V}$ ; load = 0 - 50 mA	$U_{Batt} - 1\text{ V}$		$U_{Batt}$	V
ECU Power Supply Supervision Voltage (3.3 V selected)	VDDP	ECU on	2.67	2.77	2.89	V
		ECU off	2.44	2.56	2.68	V
	IDDP	VDDP 3.3 V			800	$\mu\text{A}$

	Symbol	Condition	Min	Typ	Max	Unit
ECU Standby RAM Supervision Voltage	VDDSTBY/	VDDSTBY ↑		n.a.		V
	VDDST- BY_- SENSE	VDDSTBY ↓		n.a.		V
	IDDSTBY	VDDSTBY 1.30 V		n.a.		μA

## 7.7 Test Characteristics

Parameter	Symbol	Condition	Min	Typ	Max	Unit
Start Up Time 1*	t <sub>startup1</sub>	U <sub>Batt</sub> = 12 V Standby configured ECU_VDDP goes high	0	6	10	ms
Start Up Time 1*	t <sub>startup1</sub>	U <sub>Batt</sub> = 12 V Deep Standby con- figured ECU_VDDP goes high	100	120	275	ms
Start Up Time 2*	t <sub>startup2</sub>	U <sub>Batt</sub> goes high	100	120	275	ms

\* /PORST is not pulled low until FETK start up time



### NOTE

The reset signal /PORST can be hold or pulled low while the FETK-T5.0A is booting depending on the use the adapter ETAM8A or the adapter ETAM8B (see chapter "ETAM8 Adapter" on page 67). The FETK-T5.0A has to be configured in the XCT tool according to the needed reset signal characteristic during FETK-T5.0A standby.

## 7.8 JTAG Timing Characteristics

The FETK-T5.0A supports the JTAG mode.



### NOTE

JTAG timing parameters in this chapter refer to the JTAG interface (CON2) of the FETK-T5.0A. The JTAG wiring to the ECU (ETAM8) must be taken into account additionally.

All timings are measured at a reference level of 1.5 V.

Parameter	Symbol	Value [ns]	Comment
JTAG CLK Clock Period <sup>1)</sup> (typ.)	$t_{CLK}$	25	ETK --> Target
JTAG DIO Set-Up Time	$t_{SU}$	5	ETK --> Target
JTAG DIO Hold Time	$t_H$	5	ETK --> Target
JTAG DIO Clock-to-Out Time	$t_{CO}$	17.5	Target --> ETK
JTAG DIO Output Hold Time	$t_{OH}$	1	Target --> ETK

<sup>1)</sup>@ 40 MHz JTAG

## 7.9 Aurora Trace Timing Characteristics

Parameter	Value	Unit	Signal Impedance [Ohm]
Clock	100	MHz	100 (differential)
Data rate DATA[3..0] (max)	2500	Mbit/s	100 (differential)

## 7.10 Electrical Characteristics

## 7.10.1 ECU Interface Connector (JTAG)

Signal	Pin Type	V <sub>OL</sub> (max) [V]	V <sub>OH</sub> (min) [V]	V <sub>OH</sub> (max) [V]	V <sub>IL</sub> (max) [V]	V <sub>IH</sub> (min) [V]	V <sub>IH</sub> (max) [V]	Leakage current (max)/ (min) [μA]	Addit. load by ETK (typ) [pF] <sup>1)</sup>
TCK	XO <sup>2)</sup>	0.7	2.3	3.3	-	-	5.5	+745 / +475	16
TMS	XO <sup>2)</sup>	0.7	2.3	3.3	-	-	5.5	+50 / -82	16
TDO	IXO <sup>2)</sup>	0.7	2.3	3.3	0.8	2	5.5	+5000 / +3340	16
TDI	XO <sup>2)</sup>	0.7	2.3	3.3	-	-	6.5	+20 / -20	10
/TRST	XO <sup>2)</sup>	0.7	2.3	3.3	-	-	6.5	-705 / -485	10
/RESETOUT	IXOD <sup>3)</sup>	0.7	-	-	0.8	2	6.5	+25 / -20	22
/PORST	IXOD <sup>3)</sup>	0.7	-	-	0.8	2	6.5	+25 / -20	22
WDGDIS	XO <sup>2)</sup>	0.7	2.3	3.3	-	-	6.5	+10 / -10	10
GATE_PORST	I	-	-	-	0.8	3	3.8	+195 / +135	15

Pin Type: I: Input, X: Tristate, O: Output, OD: Open Drain

<sup>1)</sup> Adapter cable and Samtec connector not considered; PCB 1 pF/cm

<sup>2)</sup> max 12 mA

<sup>3)</sup> max 0.2 A



## 7.10.2 ECU Interface Connector Aurora Trace

Signal	Pin Type	V <sub>OL</sub> (max) [V]	V <sub>OH</sub> (min) [V]	V <sub>OH</sub> (max) [V]	V <sub>IL</sub> (max) [V]	V <sub>IH</sub> (min) [V]	V <sub>IH</sub> (max) [V]	Leakage current (min / max) [μA]	Additional load by ETK <sup>1)</sup> (typ) [pF]
TRACETRIG	I	-	-	-	0.8	1.7	3.6	-144 / -58	8
RESERVED (CRC_ERROR)	XO <sup>2)</sup>	0.6	2.4	3.1	-	-	-	+30 / -30	9

Pin Type:

I: Input, X: Tristate, O: Output, OD: Open Drain

<sup>1)</sup> Adapter cable and Samtec connector not considered; PCB 1 pF/cm

<sup>2)</sup> max 4 mA

Signal	Pin Type	V <sub>ID</sub> (min) [mV]	V <sub>ID</sub> (max) [mV]	V <sub>OD</sub> (max) [mV]
CLOCK	XO	-	-	1100
DATA[3...0]	I	110	2200	-

Pin type:

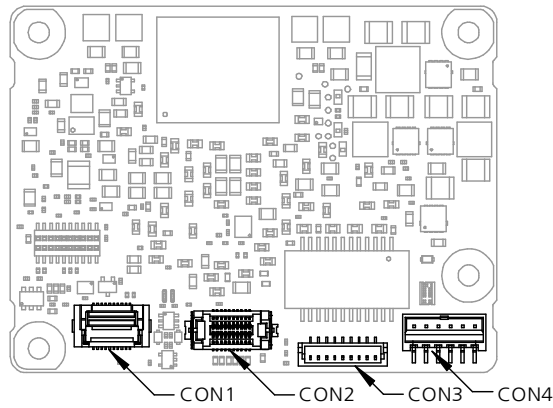
I: Input, X: Tristate, O: Output, OD: Open Drain

## 7.11 Pin Assignment

i

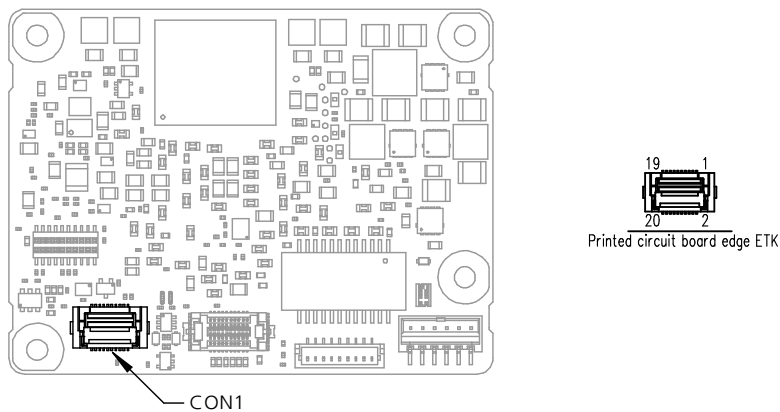
NOTE

The tables describes the pin assignment at the ETK side.



**Fig. 7-2** Location of the FETK-T5.0A Interfaces

### 7.11.1 ECU Interface Connector CON1 (JTAG)

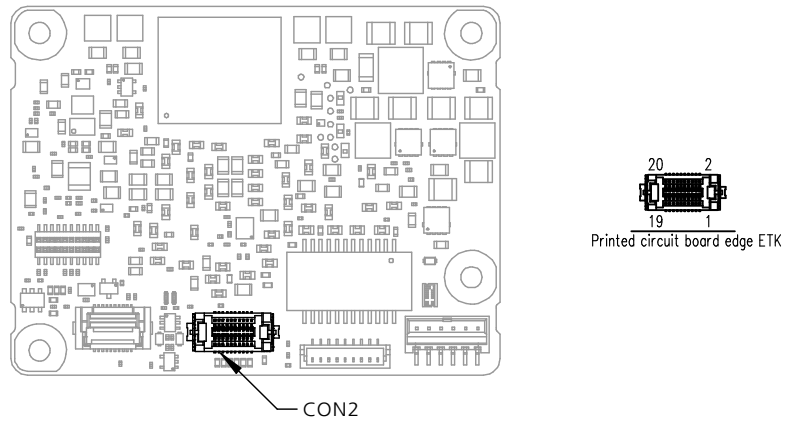


**Fig. 7-3** ECU Interface Connector CON1

Pin	Signal	Direction	Comment
1	TCK	Output	JTAG Clock signal
8	TMS	Output	JTAG Mode Select signal
4	TDO	Input	JTAG Data Out signal
2	/TRST	Output	JTAG Reset signal
10	TDI	Output	JTAG Data In signal
11	/RESETOUT	Bidir	ECU Internal Reset Status (sense, open drain output not used)
13	/PORST	Bidir	ECU Power On Reset signal (open drain) for Reset assertion and supervision

Pin	Signal	Direction	Comment
5	WDGDIS	Output	Watchdog disable Signal
18	GATE_PORST	Input	Overwrite /PORST status at Power On, 0V = /PORST inactive, 3.3V = active
7	VDDP (Sense)	Input	Sense for Switched power supply of ECU (ignition)
3, 6, 9, 12, 20	GND	Power	Signal Ground
14, 16	DNU	Output	Do Not Use, Mfr test signal
15, 17, 19	NC	-	Not Connected

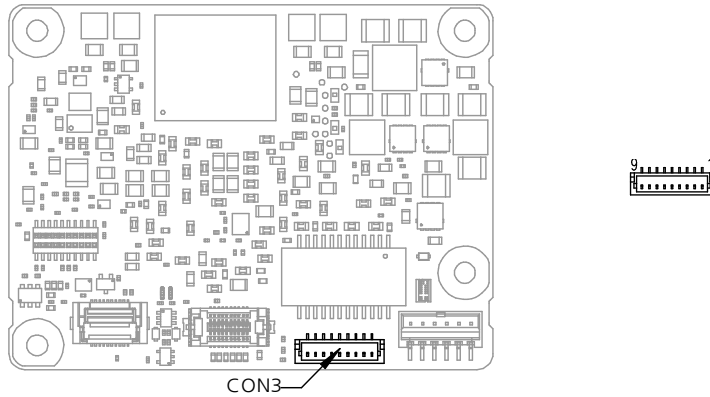
### 7.11.2 ECU Interface Connector CON2 (Aurora Trace)



**Fig. 7-4** ECU Interface Connector CON2

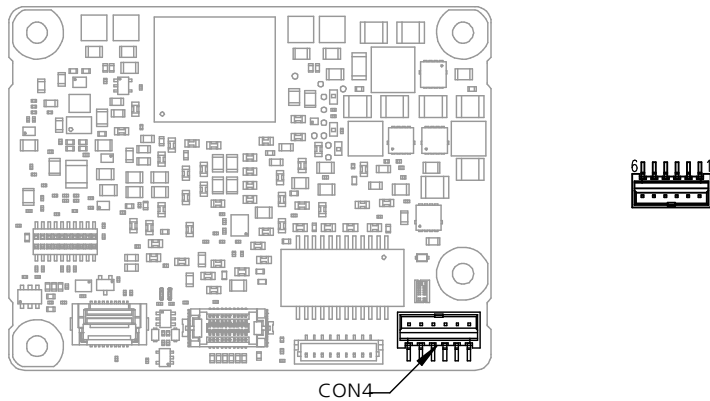
Pin	Signal	Direction	Comment
14	Clock-P	Output	Aurora Clock
12	Clock-N	Output	
4	Data0-P	Input	Aurora Data Lane 0
6	Data0-N	Input	
5	Data1-P	Input	Aurora Data Lane 1
3	Data1-N	Input	
9	Data2-P	Input	Aurora Data Lane 2
11	Data2-N	Input	
17	Data3-P	Input	Aurora Data Lane 3
15	Data3-N	Input	
18	TraceTrigger	Input	RESERVED
20	RESERVED (CRC_ERROR)	Output	Do Not Use
1, 2, 7, 8, 10, 13, 16, 19	GND		GND Signal

### 7.11.3 Ethernet Interface Connector CON3



**Fig. 7-5** Ethernet Interface Connector CON3

### 7.11.4 Power Supply Connector CON4



**Fig. 7-6** Power Supply Connector CON4

Pin	Signal	Direction	Comment
1	VDDPSTBY (3.3 V supply)	Output	Permanent power supply of ECU JTAG Interface, 3.3 V
2	VDDSTBY (0.95 V supply)	Output	Do not use
3	GND	Input	Power Ground
4	CalWakeup	Output	Switch to Ubatt. ECU wake-up signal (for measurement preparation)
5	Ubatt2	Input	Vehicle battery
6	Ubatt1	Input	Vehicle battery

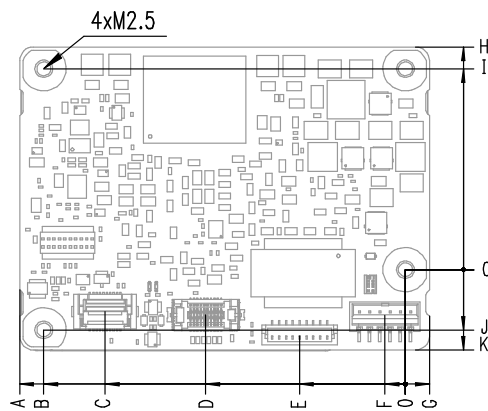
## 7.12 Mechanical Dimensions

The reference measure for all drawings is millimeters.

Item	Dimension [mm]	Dimension [in]
Length	60.00	2.362
Width	45.25	1.781
Height <sup>1)</sup>	11.55	0.455
Height <sup>2)</sup>	14.90	0.587

<sup>1)</sup>: without adapter connectors  
<sup>2)</sup>: ETAM2 mounted at CON4

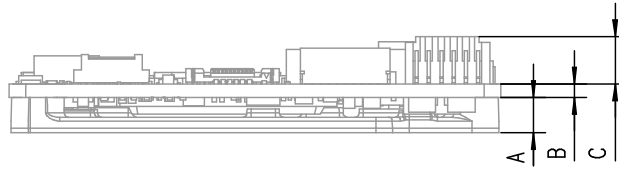
### 7.12.1 Top View



**Fig. 7-7** FETK-T5.0A Dimensions - Top View

Item	Dimension [mm]	Tolerance [mm]	Dimension [in]	Tolerance [in]
A	56.50	+/- 0.2	2.224	+/- 0.008
B	53.00	+/- 0.2	2.087	+/- 0.008
C	44.00	+/- 0.2	1.732	+/- 0.008
D	29.25	+/- 0.2	1.152	+/- 0.008
E	15.50	+/- 0.2	0.610	+/- 0.008
F	3.00	+/- 0.2	0.118	+/- 0.008
G	3.50	+/- 0.1	0.138	+/- 0.004
H	33.25	+/- 0.2	1.309	+/- 0.008
I	30.00	+/- 0.2	1.181	+/- 0.008
J	9.00	+/- 0.2	0.354	+/- 0.008
K	12.00	+/- 0.2	0.472	+/- 0.008

7.12.2 Side View



**Fig. 7-8** FETK-T5.0A Dimensions - Side View

Item	Dimension [mm]	Tolerance [mm]	Dimension [in]	Tolerance [in]
A	4.20	+/- 0.10	0.165	+/- 0.004
B	1.60	+/- 0.16	0.063	+/- 0.006
C	5.75	+0.0 -0.2	0.226	+0.000 -0.008

## 8 Cables and Accessories

### 8.1 Overview and Classification

This chapter contains information about the following topics:

- ECU Adapter Cable
  - “CBAM300 Cable” on page 57
  - “CBAM320 Cable” on page 58
  - “CBAM340 Cable” on page 59
  - “CBAM350 Cable” on page 60
- ECU Adapter and Power Supply Cable
  - “CBAM305 Cable” on page 62
- Gbit Ethernet and Power Supply Cable
  - “CBE260 Cable” on page 65
- ECU Adapter
  - “ETAM4 Adapter” on page 66
  - “ETAM8 Adapter” on page 67
- Power Supply Cable
  - “ETV5 Cable” on page 69
  - “ETAM2 Adapter” on page 70
  - “ETAM5 Adapter” on page 71
  - “ETAM9 Adapter” on page 72
  - “ETAM10/ETAM12 Adapter” on page 73

### 8.2 Requirements for failsafe Operation



#### NOTE

See chapter 4.3 on page 33 for details on wiring the ECU interface adapters.



#### NOTE

We recommend to use ETAS cables or any other cables certified by the standards for the application. Adhere to the maximum permissible cable lengths!

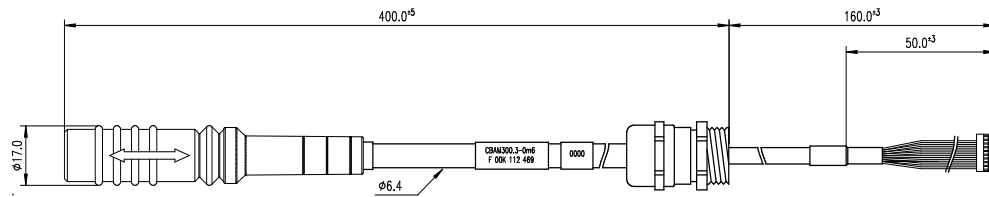


#### NOTE

Application-specific cables are available from ETAS. Please contact your ETAS contact partner or e-mail [sales.de@etas.com](mailto:sales.de@etas.com).



### 8.3 CBAM300 Cable



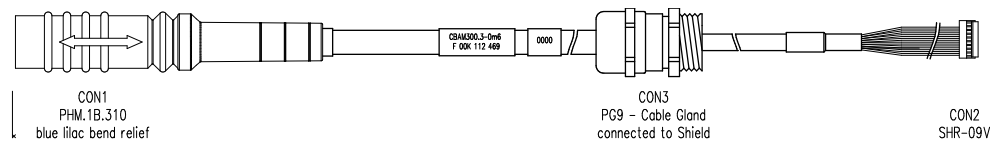
**Fig. 8-1** CBAM300.3 Cable - Dimensions

#### 8.3.1 Usage

The FETK ECU interface cable CBAM300.3 is pre-assembled into PG9 screwing, with a connected shield on screwing:

- For thin-walled housings, use a through boring with 15.2 mm in the housing and mount the cable with a nut (not included) (SM-PE 9 order number 52103210 from Lapp).
- For wall thickness more than 4 mm cut a thread into the housing.

#### 8.3.2 Connectors



**Fig. 8-2** CBAM300.3 Cable - Connectors

Connector	Color	Target
CON1	Blue purple	Gbit Ethernet cable, e.g. CBE260
CON2	White	FETK
CON3	-	Shield ECU housing

#### 8.3.3 Temperature Range

Condition	Temperature
Operating temperature	-40 °C to +125 °C / -40 °F to 257 °F

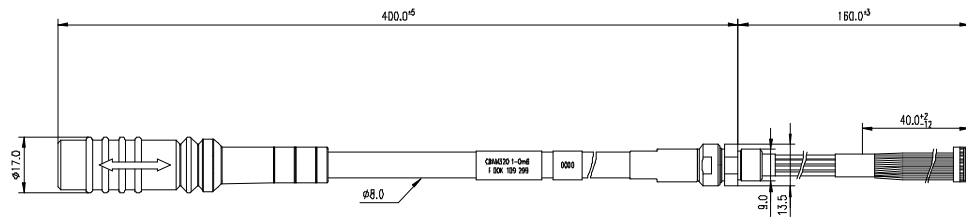
#### 8.3.4 Tightness

Condition	IP Code
PG9 screwing	IP67

#### 8.3.5 Ordering

Product	Length	Order Number
CBAM300.3-0m6	0.6 m	F 00K 112 469

## 8.4 CBAM320 Cable



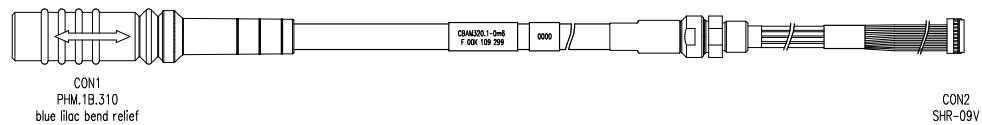
**Fig. 8-3** CBAM320 Cable - Dimensions

### 8.4.1 Usage

The CBAM320.1-0m60 ETK interface cable is a 1 Gbit/s cable adapter for FETKs. It is pre-assembled into M9 screwing, shield connected to the screwing:

- For wall thickness less than 4 mm, it is possible to use a through boring with 9.2 mm in the housing and mount the cable with a nut (included).
- For wall thickness more than 4 mm cut a thread into the housing. A special Lemo thread cutter M9 x 0.6 (Order Number: DTA.99.900.6Z) is necessary.

### 8.4.2 Connectors



**Fig. 8-4** CBAM320 Cable - Connectors

Connector	Color	Target
CON1	Blue purple	Gbit Ethernet cable, e.g. CBE260
CON2	White	FETK

### 8.4.3 Temperature Range

Condition	Temperature
Operating temperature	-40 °C to +125 °C / -40 °F to 257 °F

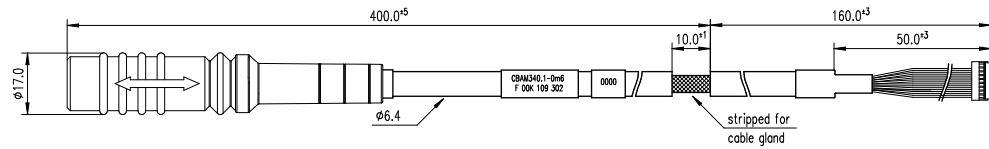
### 8.4.4 Tightness

Condition	IP Code
Cable gland M9 x 0.6	IP67

### 8.4.5 Ordering

Product	Length	Order Number
CBAM320.1-0m6	0.6 m	F 00K 109 299

## 8.5 CBAM340 Cable



**Fig. 8-5** CBAM340 Cable - Dimensions

### 8.5.1 Usage

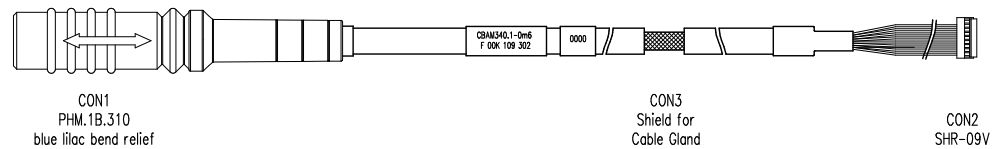
The FETK interface cable CBAM340.1 is stripped for 10 mm, to mount the cable with a EMC safe cable gland into the ECU housing.

FETK ECU Adapter Cable, shield on ECU-Housing

**i** **NOTE**

The hardware for mounting ECU adapter cables is not included in the cable delivery; they need to be ordered separately. For detailed information on mounting accessories contact ETAS technical support.

### 8.5.2 Connectors



**Fig. 8-6** CBAM340 Cable - Connectors

Connector	Color	Target
CON1	Blue purple	Gbit Ethernet cable, e.g. CBE260
CON2	White	FETK
CON3	-	Shield to ECU housing

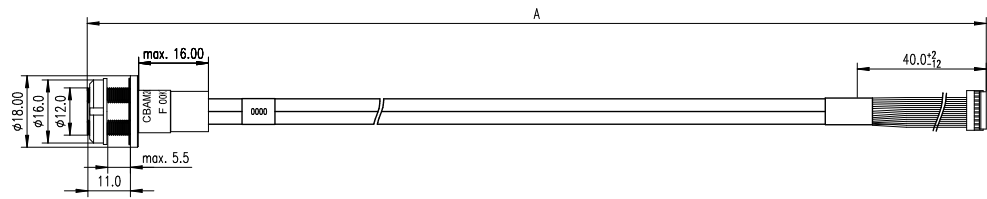
### 8.5.3 Temperature Range

Condition	Temperature
Operating temperature	-40 °C to +125 °C / -40 °F to 257 °F

### 8.5.4 Ordering

Product	Length	Order Number
CBAM340.1-0m6	0.6 m	F 00K 109 302

## 8.6 CBAM350 Cable

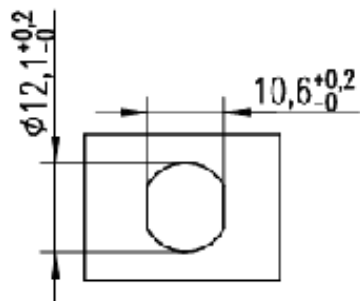


**Fig. 8-7** CBAM350 Cable - Dimensions

### 8.6.1 Usage

The CBAM350.1-0 FETK interface cable is a 1Gbit/s cable adapter with a water tight socket. The cable shield is connected to socket. It is usable for ECUs with shielded housing.

### 8.6.2 Panel Cut-Out



**Fig. 8-8** Dimension Panel Cut-Out

### 8.6.3 Assembling



A Lemo tool, type "Lemo Spanner DCH.91.161.PA" is needed for assembling the connector (not included in the delivery).



#### NOTE

The Lemo Spanner DCH.91.161.PA is not included in the cable delivery, It need to be ordered separately. For detailed information on mounting accessories contact ETAS technical support.

#### 8.6.4 Temperature Range

Condition	Temperature
Operating temperature	-40 °C to +125 °C / -40 °F to 257 °F

#### 8.6.5 Ordering

Product	Length	Order Number
CBAM350.1-0m17	0.17 m	F 00K 111 439

## 8.7 CBAM305 Cable

### 8.7.1 Usage

The CBAM305.1 FETK cable is a 1 Gbit/s Ethernet cable adapter with external power supply for FETKs.

Pre-assembled into PG9 screwing, shield connected to the screwing. It is usable for ECUs without permanent power supply inside. Depending on the version, there is a power plug on the ECU side or an open cable end on the power cable:

- For thin-walled housings, use a through boring with 15.2 mm in the housing and mount the cable with a nut (not included) (SM-PE 9 Order number 52103210 from Lapp).
- For wall thickness more than 4mm cut a thread into the housing.

If the CBAM305.1-2m2 is used, a 2 pin ERNI connector (214011 or compatible) must be available on the ECU as counterpart for the UBatt connector.

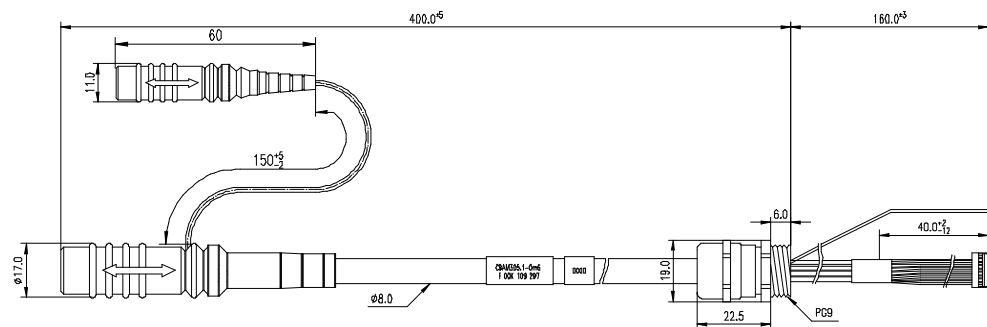
#### NOTE

It is recommended for safety reasons to connect the external permanent voltage and the switched voltage inside the ECU!

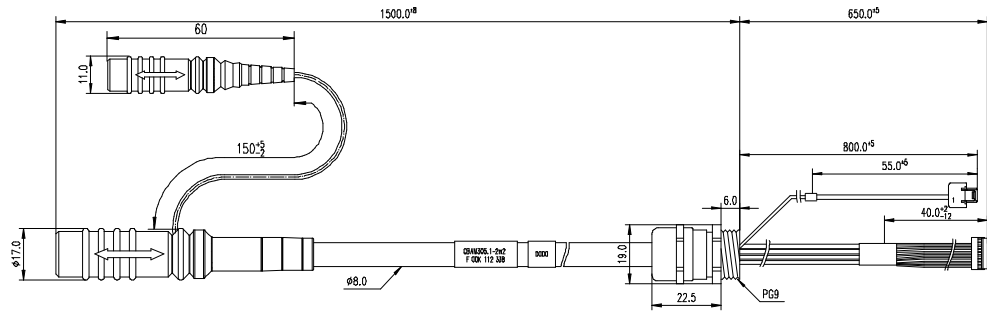
#### NOTE

For mounting the cable, cut a PG9 thread into the ECU housing. For thin-walled housings use a nut SM-PE 9. It is available from Lapp (order number: 52103210).

### 8.7.2 Dimensions

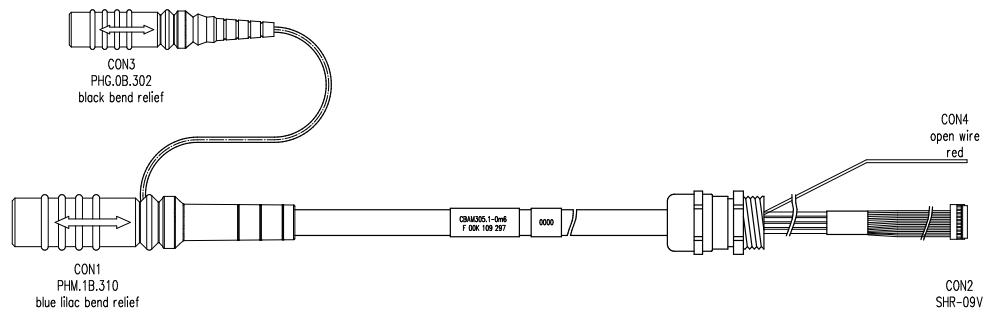


**Fig. 8-9** CBAM305.1-0m6 Cable - Dimensions



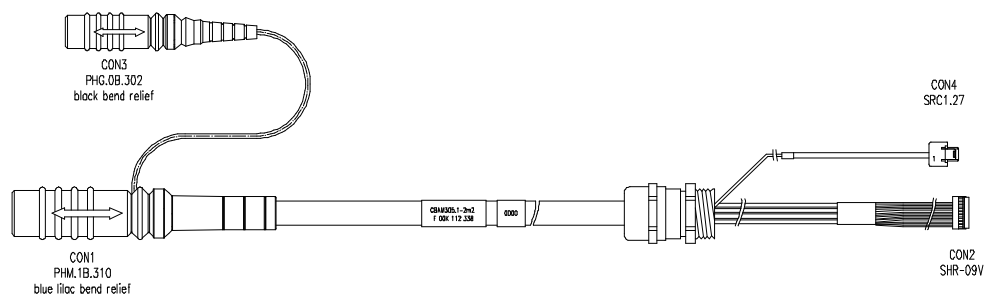
**Fig. 8-10** CBAM305.1-2m2 Cable - Dimensions

### 8.7.3 Connectors



**Fig. 8-11** CBAM305.1-0m6 - Connectors

Connector	Color	Target
CON1	Blue purple	Gbit Ethernet cable, e.g. CBE260
CON2	White	FETK
CON3	Black	Permanent power supply, K70.1 cable
CON4	Red	FETK UBATT



Connector	Color	Target
CON1	Blue purple	Gbit Ethernet cable, e.g. CBE260
CON2	White	FETK
CON3	Black	Permanent power supply, K70.1 cable
CON4	Red	2 pin ERNI power ECU connector

**Fig. 8-12** CBAM305.1-2m2 - Connectors

## 8.7.4 Temperature Range

Condition	Temperature
Operating temperature	-40 °C to +125 °C / -40 °F to 257 °F

## 8.7.5 Tightness

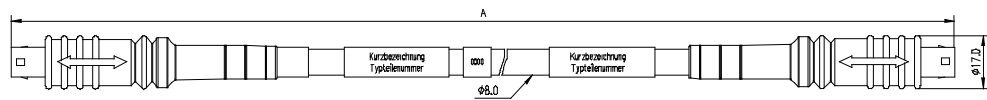
Condition	IP Code
PG9 screwing	IP67

## 8.7.6 Ordering

Product	Length	Order Number
CBAM305.1-0m6	0.6 m	F 00K 109 297
CBAM305.1-2m2	2.2 m	F 00K 112 338



## 8.8 CBE260 Cable



**Fig. 8-13** CBE260 Cable

### 8.8.1 Usage

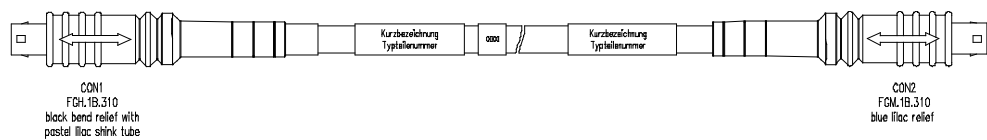
Gigabit Ethernet and Power Connection cable for FETK. Lemo connectors on both sides compliant to IP65. 3 m length.

The CBE260 cable is a Gigabit Ethernet cable to connect an ETASES device with an FETK or another ES device. The cable supports power propagation.

### 8.8.2 Dimensions

Short Name	Length A
CBE260.1-3	300 cm
CBE260.1-5	500 cm
CBE260.1-8	800 cm

### 8.8.3 Connectors



**Fig. 8-14** CBE260 - Connectors

Connector	Color	Target
CON1	Pastel purple	ES8xx Downlink
CON2	Blue purple	ES8xx Uplink, FETK

### 8.8.4 Temperature Range

Condition	Temperature
Operating temperature	-40 °C to +120°C / -40 °F to 248 °F

### 8.8.5 Ordering

Product	Length	Order Number
CBE260.1-3	3 m	F 00K 109 446
CBE260.1-5	5 m	F 00K 111 001
CBE260.1-8	8 m	F 00K 109 447

### 8.9 ETAM4 Adapter

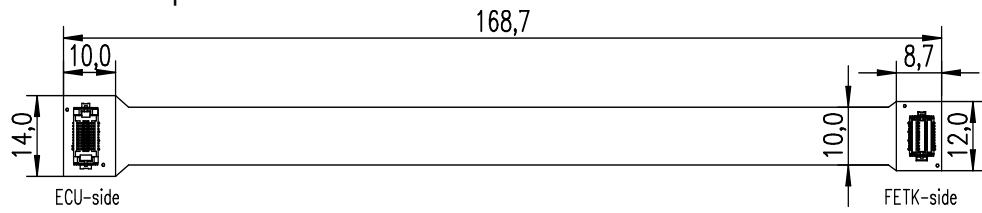


Fig. 8-15 ECU Adapter ETAM4 (Bottom View)

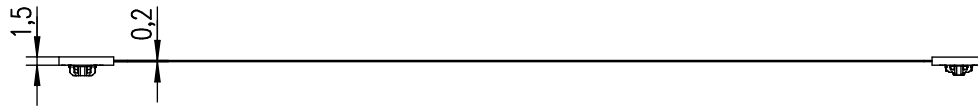


Fig. 8-16 ECU Adapter ETAM4 (Side View)

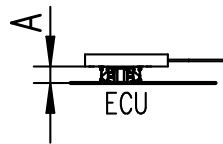


Fig. 8-17 ECU Adapter ETAM4 (Mated High)

ECU Connector	Mated Height A <sup>1)</sup> (mm)
REF-196479-010 (STH-010-0.50-G-D-K-TR)	2.00
STH-010-1.00-G-D-K-TR	2.50

<sup>1)</sup> Processing conditions will affect mated height

#### 8.9.1 Usage

The ETAM4 adapter connects the ECU microcontroller Aurora Trace signals to an FETK. It is a 1:1 adapter without active components.

The ETAM4 covers only the trace specific signals. All other signals are covered by ETAM8 and ETAM2 adapter.

#### 8.9.2 Pin Numbering

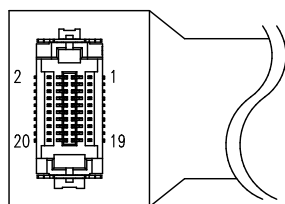
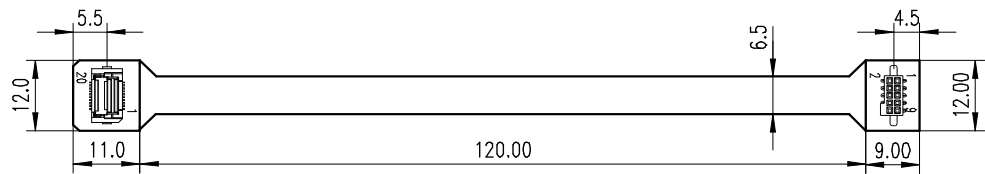


Fig. 8-18 ECU Adapter ETAM4 (Pin Numbering)

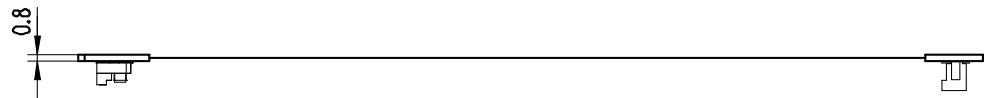
#### 8.9.3 Ordering

Product	Length	Order Number
ETAM4	0.17 m	F 00K 109 979

## 8.10 ETAM8 Adapter



**Fig. 8-19** ECU Adapter ETAM8 (Bottom View)



**Fig. 8-20** ECU Adapter ETAM8 (Side View)

### 8.10.1 Usage

The ETAM8 ECU adapter connects the ECU via a 10 pin SAMTEC TFM-105 connector to a BR\_XETK-S, FETK-S or FETK-T.

There are two variants for the ETAM8 adapter available:

- ETAM8A hold the ECU in Reset, while the ETK is booting.
- ETAM8B do not pull the Reset low while booting.

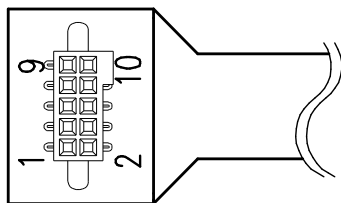
With a ETAM8B adapter the FETK-T5.0A has the same reset behavior like FETK-T1.0.



#### NOTE

See chapter "Installation" for details on mating connector to the ETAM8.

### 8.10.2 Pin Numbering



**Fig. 8-21** ECU Adapter ETAM8

### 8.10.3 ECU Connector: Signal Modes

In order to be able to use the ETK adapter ETAM8 in the ECU, a 10 pin SAMTEC connector (e.g. TFM-105-02-S-D-P) must be available on the ECU. Depending on ECU connector lead style mated height is between 6.35 mm and 11.81 mm (distance between the PCB's). JTAG is used for the FETK-T5.0A.

Pin	JTAG Mode	LFAST Mode	DAP Mode	SWD Mode
1	GND	GND	GND	GND
2	TCK	DRCLK	DAP0	SWCLK
3	/TRST	RXD-	/TRST	/TRST
4	TDO	RXD+	DAP2	Reserved (TDO)
5	TMS	TXD+	DAP1	SWDIO
6	TDI	TXD-	-	Reserved (TDI)
7	WDGDIS	WDGDIS	WDGDIS	WDGDIS
8	VDD (Sense)	VDD (Sense)	VDD (Sense)	VDD (Sense)
9	/RESETOUT	/RESETOUT	/RESETOUT	/RESETOUT
10	/PORST	/PORST	/PORST	/PORST

#### 8.10.4 Temperature Range

Condition	Temperature
Operating temperature	-40 °C to +110 °C / -40 °F to 230 °F

#### 8.10.5 Ordering

Product	Length	Order Number
ETAM8A	0.11 m	F 00K 110 754
ETAM8B	0.11 m	F 00K 110 881

## 8.11 ETV5 Cable

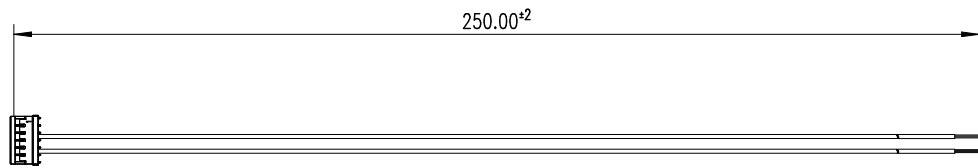


Fig. 8-22 Power Supply Cable ETV5

## 8.11.1 Usage

The ETV5 cable is an open wire power supply cable with one battery and GND connection.

**NOTE**

For better power integrity cut the cable to the shortest possible length.

**NOTE**

The ETV5 cable is a variant of the ETAM2 adapter. If ETAM2 is mentioned in this document, ETV5 might be fit as well.

See chapter "ETV5 Cable" on page 69.

## 8.11.2 Pin Assignment

Pin Number	Color	Signal	Description
1			Not connected
2			Not connected
3	Brown	GND	Power GND
4			Not connected
5	Red	SGUBATT1	Car Battery
6			Not connected

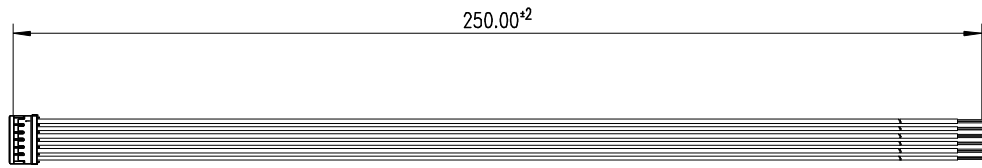
## 8.11.3 Temperature Range

Condition	Temperature
Operating temperature	-40 °C to +110 °C / -40 °F to 230 °F

## 8.11.4 Ordering

Product	Length	Order Number
ETV5	0.25 m	F 00K 111 701

## 8.12 ETAM2 Adapter



**Fig. 8-23** FETK - ECU Adapter ETAM2



### NOTE

See chapter "Installation" for details on mating connector to the ETAM2.  
The blue and yellow wires are supplied with power and must be protected.

For variant ETAM9 see also chapter "ETAM9 Adapter" on page 72.

For variant ETV5 see also chapter "ETV5 Cable" on page 69.

### 8.12.1 Pin Assignment



**Fig. 8-24** ETAM2 Connector

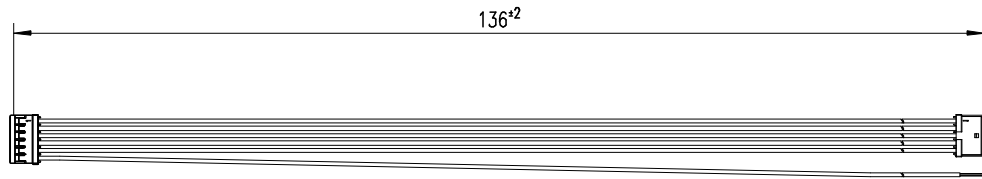
### 8.12.2 ECU Signals

Pin	Color	Signal	Description
1	Blue	VDDPSTBY (Supply)	Permanent power to supply ECU interface (optional)
2	Yellow	VDDSTBY (Supply)	Permanent power to supply ECU ED-RAM
3	Brown	GND	Power ground
4	Green	CAL_Wakeup	Switch to Ubatt. ECU wake-up signal (for measurement preparation)
5	Red	SGUBATT2	Car battery
6	Red	SGUBATT1	Car battery

### 8.12.3 Ordering

Product	Length	Order Number
ETAM2	0.25 m	F 00K 109 306

### 8.13 ETAM5 Adapter



**Fig. 8-25** FETK - ECU Adapter ETAM5

**i** **NOTE**

See chapter "Installation" for details on mating connector to the ETAM5.  
 The blue and yellow wires are supplied with power and must be protected.

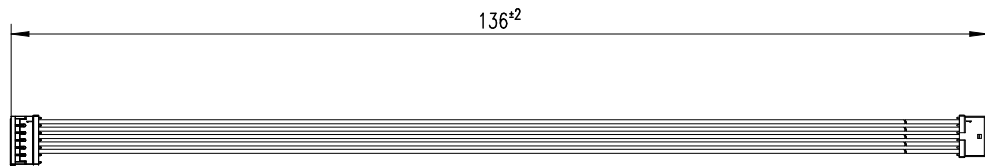
#### 8.13.1 Pin Assignment

Molex Side A	Wire: Medi cable	5 mm stripped and tinned Side B	Molex Side C
Position	Color	Position	Position
1	Blue		1
2	Yellow		2
3	Brown		3
4	Green		4
5	Red		5
6	Red		

#### 8.13.2 Ordering

Product	Length	Order Number
ETAM5	0.136 m	F 00K 110 101

## 8.14 ETAM9 Adapter



**Fig. 8-26** FETK/ XETK - ECU Adapter ETAM9

### 8.14.1 Usage

The ETAM9 adapts the FETK/ XETK power signals (Molex 6 pin connector) to the ECU with an 5 pin Molex Pico Spox connector.

The ETAM9 cable requires on the ECU side a Vertical SMT Header connector [87437-0543] or an Right Angle SMT Header connector [87438-0543].



#### NOTE

The ETAM9 adapter is a variant of the ETAM2 adapter. If ETAM2 is mentioned in this document, ETAM9 might be fit as well.

See chapter "ETAM2 Adapter" on page 70.

### 8.14.2 ECU Signals

Pin	Color	Signal	Description
1	Blue	VDDPSTBY (Supply)	Permanent power supply of ECU interface
2	Yellow	VDDSTBY (Supply)	Permanent power supply of ECU ED RAM
3	Brown	GND	Power ground
4	Green	Cal_Wakeup	Switch to Ubatt. ECU wake-up signal (for measurement preparation)
5	Red	SGUBATT1	Car battery
6	-	-	No Connect

### 8.14.3 Temperature Range

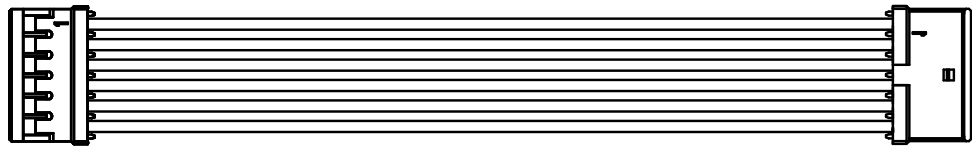
Condition	Temperature Range
Operating temperature	-40 °C to +110 °C / -40 °F to 230 °F

### 8.14.4 Order Information

Product	Length	Order Number
ETAM9	0.136 m	F 00K 111 043



### 8.15 ETAM10/ETAM12 Adapter



**Fig. 8-27** FETK/ XETK - ECU Adapter ETAM10/ETAM12

MOLEX - MOLEX (6fc - 6fc) adapter cable for connecting an FETK or XETK to the ECU.

#### 8.15.1 Usage

ETAM10 adapts the ETK power signals (Molex 6 pin connector) to an ECU with a 6 pin Molex PicoSpox connector.

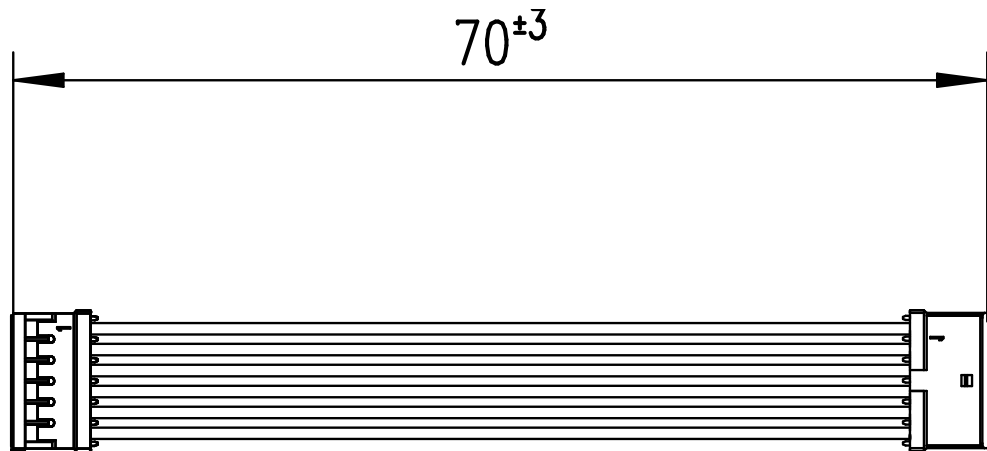
The ECU connector is available as Vertical SMT Header [87437-0643] or Right Angle SMT Header [87438-0643].

#### 8.15.2 Mechanical Dimensions

Figure shows ETAM10.

ETAM12 has a dimension of  $100 \pm 3$ .

#### 8.15.3 Dimensions



**Fig. 8-28** ETAM10 Adapter Dimensions

## 8.15.4 ECU Signals

Pin	Color	Signal	Description
1	Blue	VDDPSTBY (Supply)	Permanent power supply of ECU interface
2	Yellow	VDDSTBY (Supply)	Permanent power supply of ECU ED RAM
3	Brown	Ground	Power ground
4	Green	Cal_Wakeup	Switch to Ubatt. ECU wake-up signal (for measurement preparation)
5	Red	SGUBATT2	Car battery
6	Red	SGUBATT1	Car battery

## 8.15.5 Temperature Range

Condition	Temperature Range
Operating temperature	-40 °C to +110 °C / -40 °F to 230 °F

## 8.15.6 Order Information

Product	Length	Order Number
ETAM10	0.07 m	F 00K 111 814

## 9 Ordering Information

### 9.1 FETK-T5.0A

Order Name	Short Name	Order Number
FETK-T5.0A ECU interface for the NXP S32 ARM based microcontroller family	FETK-T5.0A	F 00K 113 728

#### Package Contents

- FETK-T5.0A Emulator Probe for NXP S32 Family
- List "Content of this Package"
- ETK Safety Advice
- China-RoHS-leaflet\_Compact\_cn

### 9.2 Cable

Please contact your local ETAS representative for further cable information.

#### 9.2.1 ECU Adapter Cable

Order Name	Short Name	Order Number
FETK ECU Adapter Cable, pre-assembled into PG9 screwing, shield on ECU- Housing, Lemo 1B PHM - JST SHR (10mc-9fc), 0m60	CBAM300.3-0m6	F 00K 112 469
FETK ECU Adapter Cable, pre-assembled into GSC.1S screwing (M9x0.6), shield on ECU- Housing, Lemo 1B PHM - JST SHR (10mc-9fc), 0m60	CBAM320.1-0m6	F 00K 109 299
FETK ECU Adapter Cable, shield on ECU-Housing, Lemo 1B PHM - JST SHR (10mc-9fc), 0m60	CBAM340.1-0m6	F 00K 109 302
FETK adapter cable, 1 Gbit/s, shield is connected to ECU, Lemo 1B HMM - JST SHR (10mc-9fc), 0m17	CBAM350.1-0m17	F 00K 111 439

### 9.2.2 ECU Adapter and Power Supply Cable

Order Name	Short Name	Order Number
FETK ECU Adapter and Power Supply Cable, pre-assembled into PG9 screwing, shield on ECU-Housing, Lemo 1B PHM - JST SHR (10mc-9fc) / Lemo 0B PHG - open wire (2fc-1c), 0m60	CBAM305.1-0m6	F 00K 109 297
FETK ECU Adapter and Power Supply Cable, pre-assembled into PG9 screwing, shield on ECU-Housing, Lemo 1B PHM - JST SHR (10mc-9fc) / Lemo 0B PHG - - Erni MiniBridge (2fc-2fc), 2m2	CBAM305.1-2m2	F 00K 112 338

### 9.2.3 Gbit Ethernet and Power Supply Cable

Order Name	Short Name	Order Number
Gbit Ethernet and Power Connection Cable, Lemo 1B FGM - Lemo 1B FGH (10fc-10mc), 3 m	CBE260.1-3	F 00K 109 446
Ethernet and Power Connection Cable 1Gbit/s, Lemo 1B FGM - Lemo 1B FGH (10fc-10mc), 5 m	CBE260.1-5	F 00K 111 001
Gbit Ethernet and Power Connection Cable for FETK, Lemo 1B FGM - Lemo 1B FGH (10fc-10mc), 8 m	CBE260.1-8	F 00K 109 447

### 9.2.4 ECU Adapter

Order Name	Short Name	Order Number
ETAM4 FETK Trace ECU Adapter, SAMTEC SSH - SAMTEC STH (20fc - 20mc), 0m17	ETAM4	F 00K 109 979
ETAM8A BR_XETK-S3 ECU Adapter, FCI - SAMTEC SFM (20c - 10fc), 0m11	ETAM8A	F 00K 110 754
ETAM8B F/XETK-S ECU Adapter, FCI - SAMTEC SFM (20c - 10fc), 0m11	ETAM8B	F 00K 110 881

### 9.2.5 Power Supply Cable

Order Name	Short Name	Order Number
ETV5 F/XETK-S ECU Adapter, MOLEX - open wires (6fc - 2c), 0m25	ETV5	F 00K 111 701
ETAM2 XETK/FETK ECU Adapter, MOLEX - open wires (6fc - 6c), 0m25	ETAM2	F 00K 109 306
ETAM5 FETK ECU Adapter, MOLEX - MOLEX (6fc - 5fc+1c), 0m136	ETAM5	F 00K 110 101
ETAM9 F/XETK-S ECU Adapter, MOLEX - MOLEX (6fc - 5fc), 0m136	ETAM9	F 00K 111 043
ETAM10 F/XETK-S ECU Adapter, MOLEX - MOLEX (6fc - 6fc), 0m07	ETAM10	F 00K 111 814

### 9.3 Isolated Power Supply (ETP2)

For special applications ETAS can offer an Isolated Power Supply Unit. The cable CBM200 is included. The ETV2 cable must be ordered separately.

For detailed information contact ETAS technical support.

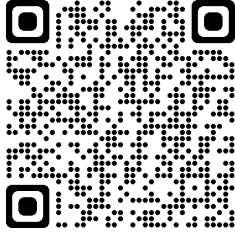
Order Name	Short Name	Order Number
ETP2 Power Supply Interface for ETK	ETP2	F 00K 104 010
ETK Power Supply Cable with Filter Coil, JST PHR – open wires (2fc-2c), 0m19	ETV2	F 00K 000 593

## 10 Contact Information

### Technical Support

For details of your local sales office as well as your local technical support team and product hotlines, take a look at the ETAS website:

[www.etas.com/en/hotlines.php](http://www.etas.com/en/hotlines.php)



### ETAS Headquarters

ETAS GmbH

Borsigstraße 24  
70469 Stuttgart  
Germany

Phone: +49 711 3423-0  
Fax: +49 711 3423-2106  
Internet: [www.etas.com](http://www.etas.com)

## Figures

Fig. 1-1	WEEE-Symbol .....	12
Fig. 2-1	FETK-T5.0A .....	14
Fig. 3-1	FETK-T5.0A Architecture .....	17
Fig. 3-2	Location of the ECU Interfaces JTAG (CON1) and Trace (CON2) .....	18
Fig. 3-3	Location of the Ethernet Interface Connector (CON3) .....	19
Fig. 3-4	Location of the Power Supply Connector (CON4) .....	20
Fig. 3-5	Status LEDs .....	21
Fig. 3-6	Equivalent Circuitry of the ECU JTAG Interface (ECU) .....	24
Fig. 4-1	Heatspreader Screws .....	29
Fig. 4-2	Attaching the FETK-T5.0A to the ECU .....	30
Fig. 4-3	Thread Locking Fluid .....	31
Fig. 4-4	FETK-T5.0A Connection to the ECU .....	32
Fig. 4-5	FETK-T5.0A Connection to the ECU .....	32
Fig. 4-6	Wiring - FETK-T5.0A Ethernet Interface .....	33
Fig. 4-7	FETK-T5.0A Power Supply wiring with CBAM300.3 Cable .....	34
Fig. 4-8	FETK-T5.0A Power Supply wiring with CBAM320.1 Cable .....	34
Fig. 4-9	FETK-T5.0A Power Supply wiring with CBAM350.1 Cable .....	35
Fig. 4-10	FETK-T5.0A Power Supply wiring with CBAM305.1 Cable .....	35
Fig. 4-11	Isolated Power Supply inside ECU .....	36
Fig. 7-1	Max. Thermal Resistance from FETK-T5.0A Heatspreader-Surface to Ambient ..	43
Fig. 7-2	Location of the FETK-T5.0A Interfaces .....	50
Fig. 7-3	ECU Interface Connector CON1 .....	50
Fig. 7-4	ECU Interface Connector CON2 .....	52
Fig. 7-5	Ethernet Interface Connector CON3 .....	53
Fig. 7-6	Power Supply Connector CON4 .....	53
Fig. 7-7	FETK-T5.0A Dimensions - Top View .....	54
Fig. 7-8	FETK-T5.0A Dimensions - Side View .....	55
Fig. 8-1	CBAM300.3 Cable - Dimensions .....	57
Fig. 8-2	CBAM300.3 Cable - Connectors .....	57
Fig. 8-3	CBAM320 Cable - Dimensions .....	58
Fig. 8-4	CBAM320 Cable - Connectors .....	58
Fig. 8-5	CBAM340 Cable - Dimensions .....	59
Fig. 8-6	CBAM340 Cable - Connectors .....	59
Fig. 8-7	CBAM350 Cable - Dimensions .....	60
Fig. 8-8	Dimension Panel Cut-Out .....	60
Fig. 8-9	CBAM305.1-0m6 Cable - Dimensions .....	62
Fig. 8-10	CBAM305.1-2m2 Cable - Dimensions .....	63

Fig. 8-11	CBAM305.1-0m6 - Connectors .....	63
Fig. 8-12	CBAM305.1-2m2 - Connectors .....	63
Fig. 8-13	CBE260 Cable .....	65
Fig. 8-14	CBE260 - Connectors .....	65
Fig. 8-15	ECU Adapter ETAM4 (Bottom View) .....	66
Fig. 8-16	ECU Adapter ETAM4 (Side View) .....	66
Fig. 8-17	ECU Adapter ETAM4 (Mated High) .....	66
Fig. 8-18	ECU Adapter ETAM4 (Pin Numbering) .....	66
Fig. 8-19	ECU Adapter ETAM8 (Bottom View) .....	67
Fig. 8-20	ECU Adapter ETAM8 (Side View) .....	67
Fig. 8-21	ECU Adapter ETAM8 .....	67
Fig. 8-22	Power Supply Cable ETV5 .....	69
Fig. 8-23	FETK - ECU Adapter ETAM2 .....	70
Fig. 8-24	ETAM2 Connector .....	70
Fig. 8-25	FETK - ECU Adapter ETAM5 .....	71
Fig. 8-26	FETK/ XETK - ECU Adapter ETAM9 .....	72
Fig. 8-27	FETK/ XETK - ECU Adapter ETAM10/ETAM12 .....	73
Fig. 8-28	ETAM10 Adapter Dimensions .....	73



## Index

<b>A</b>	
Adapter	
ETAM10/ETAM12	73
ETAM2	70
ETAM4	66
ETAM5	71
ETAM8	67
ETAM9	72
Applications	14
Architecture	17
<b>B</b>	
Block diagram	17
<b>C</b>	
Cable	
CBAM300	57
CBAM305	62
CBAM320	58
CBAM340	59
CBAM350	60
CBE260	65
ETV5	69
Calibration Data Access	22
Configuration	41
Configuration Parameter	38
<b>D</b>	
Data Access	22
Data Emulation Memory	41
Direct measurement	23
<b>E</b>	
ECU	
Interface	18
Voltage Supervisor	20
Electrical Characteristics	48
Environmental Conditions	42
Ethernet Interface	19
ETK / XETK / FETK Configuration	37
ETV2	77
<b>F</b>	
Features	14
FETK Ethernet Interface	19
<b>H</b>	
Hardware Description	17
<b>I</b>	
Identifications on the product	11
Interface	
ECU	18
Introduction	14
Isolated Power Supply	36
Isolated Power Supply (ETP2)	77
<b>J</b>	
JTAG Interface	24
<b>L</b>	
LED	21
<b>M</b>	
Measurement Data Access	23
Measurement Data Memory	41
Mechanical Dimension	54
Mounting to the ECU Housing	28
Mounting Material	28
Thermal Connection	28
<b>P</b>	
PC network adapter	40
Pin Assignment	50
Power Supply	20, 33
Cables, combined	76
Connector	20
Product Back	12
<b>R</b>	
REACH regulation (EU)	13
Recycling	12
Reset	27
RoHS conformity	
China	13
European Union	12
<b>S</b>	
Software Support	41
Status LED	21
System Requirements	40
<b>T</b>	
Test Characteristics	46
Trace Measurement	23
Troubleshooting	39
<b>U</b>	
UKCA conformity	12
<b>V</b>	
Voltage Supervisor	20
<b>W</b>	
Waste Electrical and Electronic Equipment	12
WEEE	12
WEEE take-back system	12