A decorative graphic consisting of two red lines that intersect. One line starts from the top right and goes towards the center, while the other starts from the top left and goes towards the center. They meet at a point marked with a small white circle. A second red line extends from this intersection point towards the bottom left, ending in a small red dot. The background is a gradient of blue, darker at the top and lighter at the bottom.

ETAS FETK-S2.1 Emulator Probe for MPC57xx and EMU57xx MCU Family

User Guide

Copyright

The data in this document may not be altered or amended without special notification from ETAS GmbH. ETAS GmbH undertakes no further obligation in relation to this document. The software described in it can only be used if the customer is in possession of a general license agreement or single license. Using and copying is only allowed in concurrence with the specifications stipulated in the contract.

Under no circumstances may any part of this document be copied, reproduced, transmitted, stored in a retrieval system or translated into another language without the express written permission of ETAS GmbH.

© **Copyright 2021** ETAS GmbH, Stuttgart

The names and designations used in this document are trademarks or brands belonging to the respective owners.

FETK-S2.1 - User Guide R06 EN - 07.2021

Contents

1	About this Document	7
1.1	Classification of Safety Messages	7
1.2	Presentation of Instructions	7
1.3	Typographical Conventions	8
1.4	Presentation of Supporting Information	8
2	Basic Safety Notices	9
2.1	General Safety Information	9
2.2	Requirements for Users and Duties for Operators	9
2.3	Intended Use	9
2.4	Identifications on the Product	13
2.5	Taking the Product Back and Recycling	14
2.6	Declaration of Conformity	14
	2.6.1 CE Declaration of Conformity (European Union)	14
	2.6.2 UKCA Declaration of Conformity (Great Britain)	14
2.7	RoHS Conformity	14
	2.7.1 European Union	14
	2.7.2 China	15
2.8	Declarable Substances	15
2.9	Use of Open Source Software	15
3	Introduction	16
3.1	Applications	16
3.2	Features	17
	3.2.1 General	17
	3.2.2 Measurement	17
	3.2.3 Calibration	17
	3.2.4 ECU Flash Programming via FETK	18
	3.2.5 Further Characteristics	18
4	Hardware Description	19
4.1	Architecture	19
4.2	ECU Interface	20
4.3	FETK Ethernet Interface	21
4.4	Power Supply	22
4.5	ECU Voltage Supervisor	22
4.6	Data Emulation and Data Measurement	23
4.7	JTAG and LFAST Interface	24
	4.7.1 Layout Recommendation for LFAST Mode	24
	4.7.2 Debugger and MC Support	24
4.8	Trigger Modes: Overview	24
4.9	Pinless Triggering	25
	4.9.1 Startup Handshake	25

4.9.2	FETK Trigger Generation	25
4.10	Timer Triggering	26
4.11	Reset	26
4.12	Pull CalWakeUp until Startup Handshake	26
5	Installation	27
5.1	Mounting the FETK-S2.1 into the ECU Housing	27
5.1.1	Thermal Connection Requirements	27
5.1.2	Mounting Material	27
5.1.3	Mounting Steps	28
5.2	Connection to the ECU	30
5.3	Wiring	31
5.3.1	FETK Ethernet Interface	31
5.3.2	Power Supply	31
6	ETK / XETK / FETK Configuration	34
6.1	Overview	34
6.2	Configuration Parameter	35
7	Technical Data	36
7.1	System Requirements	36
7.1.1	ETAS Compatible Hardware	36
7.1.2	PC with one Ethernet Interface	36
7.1.3	Software Support	37
7.2	Data Emulation and Measurement Memory	37
7.2.1	Data Emulation Memory and Microcontroller Support	37
7.2.2	Measurement Data Memory	38
7.3	FETK Ethernet Interface	38
7.4	Environmental Conditions	38
7.5	Power Supply	39
7.6	Test Characteristics	39
7.7	JTAG Timing Characteristics	40
7.7.1	JTAG Timing Diagram	40
7.7.2	JTAG Timing Parameters	40
7.8	Electrical Characteristics	41
7.8.1	ECU Interface Characteristics	41
7.8.2	ECU Interface Connector CON1	42
7.9	Pin Assignment	44
7.9.1	ECU Interface Connector CON1	44
7.9.2	Power Supply Connector CON2	47
7.9.3	FETK Ethernet Interface Connector CON3	47
7.10	Mechanical Dimensions	48
7.10.1	Top View	48
7.10.2	Side View	49
8	Cables and Accessories	50
8.1	Overview and Classification	50
8.2	Requirements for failsafe Operation	50

8.3	CBAM300 Cable	51
8.3.1	Usage	51
8.3.2	Connectors	51
8.3.3	Temperature Range	51
8.3.4	Tightness	51
8.3.5	Ordering	51
8.4	CBAM320 Cable	52
8.4.1	Usage	52
8.4.2	Connectors	52
8.4.3	Temperature Range	52
8.4.4	Tightness	52
8.4.5	Ordering	52
8.5	CBAM340 Cable	53
8.5.1	Usage	53
8.5.2	Connectors	53
8.5.3	Temperature Range	53
8.5.4	Ordering	53
8.6	CBAM350 Cable	54
8.6.1	Usage	54
8.6.2	Panel Cut-Out	54
8.6.3	Assembling	54
8.6.4	Temperature Range	55
8.6.5	Ordering	55
8.7	CBAM305 Cable	56
8.7.1	Usage	56
8.7.2	Dimensions	56
8.7.3	Connectors	57
8.7.4	Temperature Range	58
8.7.5	Tightness	58
8.7.6	Ordering	58
8.8	CBE260 Cable	59
8.8.1	Usage	59
8.8.2	Dimensions	59
8.8.3	Connectors	59
8.8.4	Temperature Range	59
8.8.5	Ordering	59
8.9	ETAM8 Adapter	60
8.9.1	Usage	60
8.9.2	Pin Numbering	60
8.9.3	ECU Connector: Signal Modes	61
8.9.4	Temperature Range	61
8.9.5	Ordering	61
8.10	ETV5 Cable	62
8.10.1	Usage	62
8.10.2	Pin Assignment	62
8.10.3	Temperature Range	62
8.10.4	Ordering	62
8.11	ETAM2 Adapter	63
8.11.1	Pin Assignment	63
8.11.2	ECU Signals	63
8.11.3	Ordering	63
8.12	ETAM5 Adapter	64

8.12.1	Pin Assignment	64
8.12.2	Ordering	64
8.13	ETAM9 Adapter	65
8.13.1	Usage	65
8.13.2	ECU Signals	65
8.13.3	Temperature Range	65
8.13.4	Order Information	65
8.14	ETAM10 Adapter	66
8.14.1	Usage	66
8.14.2	Dimensions	66
8.14.3	ECU Signals	67
8.14.4	Temperature Range	67
8.14.5	Order Information	67
9	Ordering Information	68
9.1	FETK-S2.1	68
9.2	Cable	68
9.2.1	ECU Adapter Cable	69
9.2.2	ECU Adapter and Power Supply Cable	69
9.2.3	Gbit Ethernet and Power Supply Cable	70
9.2.4	ECU Adapter	70
9.2.5	Power Supply Cable	70
9.3	Power Supply	70
10	Contact Information	71
	Figures	72
	Index	74

1 About this Document

1.1 Classification of Safety Messages

The safety messages used here warn of dangers that can lead to personal injury or damage to property:



DANGER

indicates a hazardous situation with a high risk of death or serious injury if not avoided



WARNING

indicates a hazardous situation of medium risk which could result in death or serious injury if not avoided.



CAUTION

indicates a hazardous situation of low risk which may result in minor or moderate injury if not avoided.

NOTICE

indicates a situation which may result in damage to property if not avoided.

1.2 Presentation of Instructions

The target to be achieved is defined in the heading. The necessary steps for this are in a step-by-step guide:

Target definition

1. Step 1
2. Step 2
3. Step 3
- > Result

1.3 Typographical Conventions

Software

OCI_CANTxMessage msg0 =	Code snippets are presented on a gray background and in the Courier font. Meaning and usage of each command are explained by means of comments. The comments are enclosed by the usual syntax for comments.
Choose File → Open .	Menu commands are shown in boldface.
Click OK .	Buttons are shown in boldface.
Press <ENTER>.	Keyboard commands are shown in angled brackets.
The "Open File" dialog box is displayed.	Names of program windows, dialog boxes, fields, etc. are shown in quotation marks.
Select the file <code>set up . exe</code> .	Text in drop-down lists on the screen, program code, as well as path- and file names are shown in the Courier font.
<i>A distribution</i> is always a one-dimensional table of sample points.	General emphasis and new terms are set in italics.

Hardware

Bold	Menu commands, buttons, labels of the product
<i>Italic</i>	Emphasis on content and newly introduced terms

1.4 Presentation of Supporting Information



NOTE

Contains additional supporting information.

2 Basic Safety Notices

This chapter contains information about the following topics:

- General Safety Information 9
- Requirements for Users and Duties for Operators 9
- Intended Use 9
- Identifications on the Product 13
- Taking the Product Back and Recycling 14
- Declaration of Conformity 14
- RoHS Conformity 14
- Declarable Substances. 15
- Use of Open Source Software. 15

2.1 General Safety Information

Please observe the Product Safety Notices ("ETAS Safety Notice") and the following safety notices to avoid health issues or damage to the device.



NOTE

Carefully read the documentation (Product Safety Advice and this User Guide) that belongs to the product prior to the startup.

ETAS GmbH does not assume any liability for damages resulting from improper handling, unintended use or non-observance of the safety precautions.

2.2 Requirements for Users and Duties for Operators

The product may be assembled, operated and maintained only if you have the necessary qualification and experience for this product. Improper use or use by a user without sufficient qualification can lead to damages or injuries to one's health or damages to property.

The safety of systems using the product is the responsibility of the system integrator.

General Safety at Work

The existing regulations for safety at work and accident prevention must be followed. All applicable regulations and statutes regarding operation must be strictly followed when using this product.

2.3 Intended Use

An ETK is an electronic component that is installed in a vehicle control unit (ECU) to read data from the ECU or write data to the ECU.

Application Area of the Product

This product was developed and approved for automotive applications. For use in other application areas, please contact your ETAS contact partner.

Requirements for Operation

The following requirements are necessary for safe operation of the product:

- Use the product only according to the specifications in the corresponding User Guide. With any deviating operation, the product safety is no longer ensured.
- Observe the regulations applicable at the operating location concerning electrical safety as well as the laws and regulations concerning work safety!
- Do not apply any voltages to the connections of the product that do not correspond to the specifications of the respective connection.
- Connect only current circuits with safety extra-low voltage in accordance with EN 61140 (degree of protection III) to the connections of the product.
- The power supply for the product must be safely disconnected from the supply voltage. For example, use a car battery or a suitable lab power supply.
- Use only lab power supplies with double protection to the supply system.
- Ensure that the connections of the power supply are easily accessible.
- The module does not have an operating voltage switch.
 - Switch on the product by connecting the power supply cable with the power supply or by switching on the power supply.
 - Switch off the product by disconnecting it from the power supply or by switching off the power supply.



DANGER

Connect the power cord only with a vehicle battery or with a lab power supply! A connection to power outlets is prohibited.

Route the power cord in such a way that it is protected against abrasion, damages, deformation and kinking. Do not place any objects on the power cord.

Never apply force to insert a plug into a socket. Ensure that there is no contamination in and on the connection, that the plug fits the socket, and that you correctly aligned the plugs with the connection.

Do not use the product in a wet or damp environment.

Do not use the product in potentially explosive atmospheres.

Keep the surfaces of the product clean and dry.

Potential Equalization



CAUTION

Danger from inadvertent current flow!

Depending on the design, the shield of the Ethernet cables can be connected with the housing of the module. Install the products only on components with the same electrical potential or isolate the products from the components.

Requirements for the technical State of the Product

The product is designed in accordance with state-of-the-art technology and recognized safety rules. The product may be operated only in a technically flawless condition and according to the intended purpose and with regard to safety and dangers as stated in the respective product documentation. If the product is not used according to its intended purpose, the protection of the product may be impaired.

Maintenance and Cleaning

The product is maintenance-free. Use a lightly moistened, soft, lint-free cloth for cleaning the product. Ensure that no moisture can enter. Never spray cleaning agents directly onto the product. Do not use any sprays, solvents or abrasive cleaners which could damage the product.

Transport and Installation



CAUTION

The ETK can be damaged or destroyed!

Some components of the ETK board may be damaged or destroyed by electrostatic discharges. Please keep the ETK in its storage package until it is installed.

The board should only be taken from its package, configured, and installed at a work place that is protected against static discharge.



CAUTION

During installation and removal, ECU and ETK must be in a de-energized state!



CAUTION

Risk of short circuiting the internal signals of the ETK!

When you mount the ETK to the ECU, you must ensure that the screws and washers used will not penetrate the ETK printed circuit board.

**CAUTION**

Differences in case ground potentials can cause high currents to flow through the shields of the cables that connect various system modules.

Ensure that the module mounting surfaces are at the same electrical potential or insulate the modules from their mounting surfaces.

Cabling







Use exclusively ETAS cables at the connections of the product! Adhere to the maximum permissible cable lengths! Observe the assignment of the cables to the connectors! Detailed information about cabling is located in the ETK User Guides.

2.4 Identifications on the Product



Fig. 2-1 Adhesive Label (Example: Label for XETK-S14.0)

The following symbols are used for identifications of the product: (

Symbol	Description
	The User Guide must be read prior to the startup of the product!
	WEEE symbol, see chapter 2.5 on page 14
	CE conformity symbol (European Union), see chapter 2.6.1 on page 14
	UKCA conformity symbol (Great Britain), see chapter 2.6.2 on page 14)
	China RoHS symbol, see chapter 2.7.2 on page 15
	China RoHS symbol, see chapter 2.7.2 on page 15
	Symbol for electrostatic sensitive components
XETK-S14.0A	Product designation (example)
F 00K 110 722	Order number of the product (example)
SN: yyxxxxx	Serial number (7-digit)
XXXX/YY	Product version
ZZZZ	Year of manufacture
ETAS GmbH, PO Box 300220, 70442 Stuttgart, Germany	Manufacturer's address

**NOTE**

For symbols and product information one or several adhesive labels can be used.

2.5 Taking the Product Back and Recycling

The European Union has passed a directive called Waste Electrical and Electronic Equipment, or WEEE for short, to ensure that systems are setup throughout the EU for the collection, treating and recycling of electronic waste.

This ensures that the devices are recycled in a resource-saving way representing no danger to health or the environment.



Fig. 2-2 WEEE-Symbol

The WEEE symbol (see Fig. 2-2 on page 14) on the product or its packaging shows that the product must not be disposed of as residual garbage.

The user is obliged to collect the old devices separately and return them to the WEEE take-back system for recycling. The WEEE directive concerns all ETAS devices but not external cables or batteries.

For more information on the ETAS GmbH Recycling software, contact the ETAS sales and service locations.

2.6 Declaration of Conformity

2.6.1 CE Declaration of Conformity (European Union)

With the CE mark attached to the product or its packaging, ETAS confirms that the product corresponds to the applicable product-specific European Directives. The CE Declaration of Conformity for the product is available upon request.

2.6.2 UKCA Declaration of Conformity (Great Britain)

With the UKCA mark attached to the product or its packaging, ETAS confirms that the product corresponds to the product-specific, applicable standards and directives of Great Britain. The UKCA declaration of conformity for the product is available on request.

2.7 RoHS Conformity

2.7.1 European Union

The EU Directive 2011/65/EU limits the use of certain dangerous materials for electrical and electronic devices (RoHS conformity).

This product does not contain any of the restricted substances specified in the EU Directive 2011/65/EU or exceeds the maximum concentrations stipulated therein. For individual electronic components used in our products, there are currently no equivalent alternative substances, which is why we make use of the exception 7A and 7C-I in Annex III of this Directive.

ETAS confirms that the product corresponds to this directive which is applicable in the European Union.

2.7.2 China

ETAS confirms that the product meets the product-specific applicable guidelines of the China RoHS (Management Methods for Controlling Pollution Caused by Electronic Information Products Regulation) applicable in China with the China RoHS marking affixed to the product or its packaging.

2.8 Declarable Substances

European Union

Some products from ETAS GmbH (e.g. modules, boards, cables) use components with substances that are subject to declaration in accordance with the REACH regulation (EU) no.1907/2006.

Detailed information is located in the ETAS download center in the customer information "REACH Declaration" (www.etas.com/Reach). This information is continuously being updated.

2.9 Use of Open Source Software

The product uses Open Source Software (OSS). This software is installed in the product at the time of delivery and does not have to be installed or updated by the user. Reference shall be made to the use of the software in order to fulfill OSS licensing terms. Additional information is available in the document "OSS Attributions List" at the ETAS website www.etas.com.

3 Introduction

This chapter contains information about the following topics:

- Applications 16
- Features 17

3.1 Applications

The FETK-S2.1 is an emulator probe for the NXP Freescale MPC57xx and for the STMicroelectronics EM57xx and EM58 microcontroller family. It is a serial FETK designed for use with the JTAG debug interface (IEEE/ISTO 5001).

 **NOTE**

For supported MPC57xx microcontrollers, refer to chapter 7.1.3 on page 37.

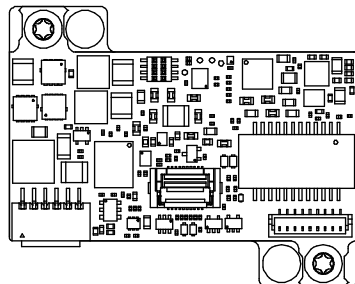

Fig. 3-1 FETK-S2.1

	FETK-S2.1
FETK ECU interface connector	10 pin SAMTEC
FETK power supply connector	6 pin MOLEX
Power supply for ED devices (VDDS-BRAM)	min. 1.25 V
SBRAM sense	Yes, on board or external sense
Pinless triggering	Yes
Timer triggering	Yes

To access the ECU the FETK-S2.1 has to be connected via ES89x modules.

The system can be used for high speed Measurement, Calibration and ECU flash programming. Support of Rapid Prototyping applications e.g. functional prototyping - bypass depends on the functionality of the connected modules.

The FETK-S2.1 and ES89x system uses the standardized protocol "XCP on Ethernet" for PC communication. Thus 3rd party tools can be connected to the ECU as well.

3.2 Features

3.2.1 General

- Gigabit Ethernet Interface:
 - Connection to PC via ES89x modules
 - Proprietary Ethernet protocol for FETKs
 - Supports a variety of standard applications
- Calibration and measurement access performed via the microcontroller JTAG or LFAST interface
 - 3.3 V and 5.0 V JTAG output levels, configurable
 - Configurable JTAG interface clock speed
 - Configurable LFAST reference clock and transfer rate



NOTE

The max. allowed JTAG clock depends on the core frequency of the micro-controller. Max. clock speed is typically 1/4 of the core frequency.

- Permanent storage of configuration in EEPROM
- Third party MC-tool support via ES89x module possible

3.2.2 Measurement

- Fast measurements – ECU raster at under 74 μ s
- Supports “turnkey mechanism” - measurement start immediately after “Ignition on” and proceed measurement during ECU reset
- Pin-less ECU handshake and trigger mechanism
- Hook-based (DISTAB) and hook-less measurement approaches

3.2.3 Calibration

- Concurrent use of calibration and measurement performed via microcontroller debug interface
- Working Page & Reference Page (2 page concept) realized by microcontroller overlay mechanism
- Direct access to parameters, curves, and maps in internal RAM
- Microcontroller capability of internal Flash emulation can be used
- FETK powers Emulation Device RAM (for calibration purpose)
- Supports “Start on Any Page”
- Supports special coldstart mechanism (“Calibration Wake Up”):
 - Calibration Wake Up: Wake up mechanism to wake up the power supply of the ECU via the Calibration Wake up pin
 - Pull CalWakeUp until Startup Handshake: duration of the Wake up mechanism is configurable

3.2.4 ECU Flash Programming via FETK

- Using microcontroller debug interface, ECU software support not necessary
- Brainedead flashing under ProF control

3.2.5 Further Characteristics

- "ETK Drivers and Tools" update to support ETAS software tools (INCA, XCT)
- Firmware update (programming of the logic device) through HSP software service packs; removal of FETK or ECU is not necessary
- Mounting possibilities inside or on top of ECU
- Temperature range suitable for automotive application

For more technical data on the FETK-S2.1 consult the chapter "Technical Data" on page 36.

4 Hardware Description

This chapter contains information about the following topics:

- Architecture 19
- ECU Interface 20
- FETK Ethernet Interface 21
- Power Supply 22
- ECU Voltage Supervisor 22
- Data Emulation and Data Measurement 23
- JTAG and LFAST Interface 24
- Trigger Modes: Overview 24
- Pinless Triggering 25
- Timer Triggering 26
- Reset 26
- Pull CalWakeUp until Startup Handshake 26

4.1 Architecture

Fig. 4-1 shows the block diagram of the FETK-S2.1.

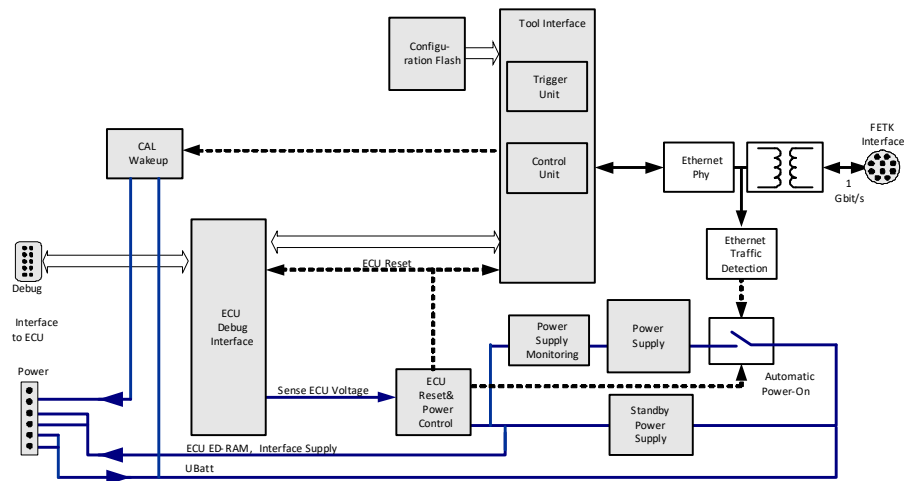

Fig. 4-1 FETK-S2.1 Architecture

While the microcontroller accesses the program data (not the program code) out of the data emulation memory provided by the microcontroller, the content of the data emulation memory can simultaneously be modified by the calibration and development system through the FETK Ethernet interface. This process enables adjustments of parameters, characteristic lines and maps through the calibration and development system. Using an additional measurement data memory area, the ECU microcontroller can provide data to the calibration and development system by buffering the data (DISTAB17) and triggering the FETK to read the data via JTAG or LFAST. The FETK then reads, buffers, processes and sends this measured data to the PC.

If no additional measurement data memory is available, the FETK-S2.1 can alternatively read the data to be measured directly from the microcontroller's memory. This process is Triggered Direct Measurement (TDM) with DISTAB17.

The 100/1000 Mbit/s FETK Ethernet interface provides communication with the PC.

FETK Connector	Description
CON1	ECU Interface
CON2	Power supply
CON3	Ethernet interface (ES89x module)

4.2 ECU Interface

The FETK-S2.1 is connected via connectors CON1 and CON2 to the ECU with two adapter cables (refer to Fig. 4-2 on page 20). The pin definition depends on the application and the microcontroller type. In general the ECU interface consists of

- 1 ECU voltage line, which is not used for FETK power supply, but only for detection of the ECU status, therefore the power consumption on this line is negligible (refer to chapter 4.4 on page 22)
- 1 Reset line which allows the FETK to control the system reset of the ECU
- 1 Reset line which allows the FETK to monitor the system reset of the ECU
- 5 Debug line interfaces for the communication between the FETK-S2.1 and the microcontroller
- 1 Watchdog disable line
- 1 ground line

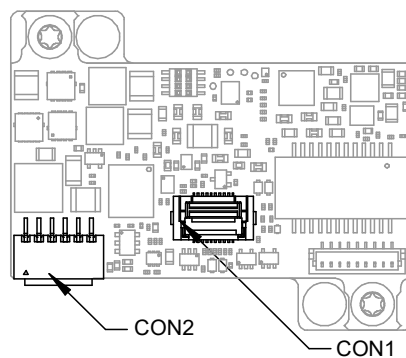

Fig. 4-2 Location of the ECU Interfaces

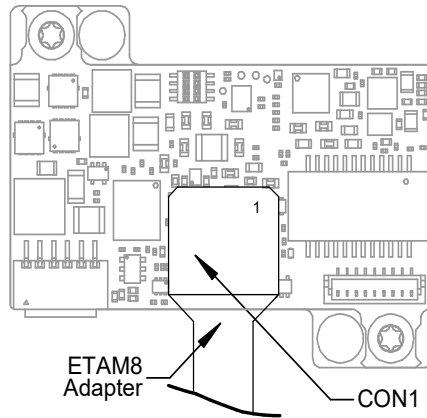

Fig. 4-3 ETAM8 Adapter mounted at CON1

4.3 FETK Ethernet Interface

The FETK Ethernet interface utilizes a proprietary Ethernet protocol. It has to be connected to the PC via a ES89x ECU Interface Module at CON3 (refer to Fig. 4-4).

NOTE

The FETK Ethernet interface utilizes a proprietary Ethernet protocol and is compatible only with the Gigabit Ethernet interfaces of the ES89x ECU Interface Module.

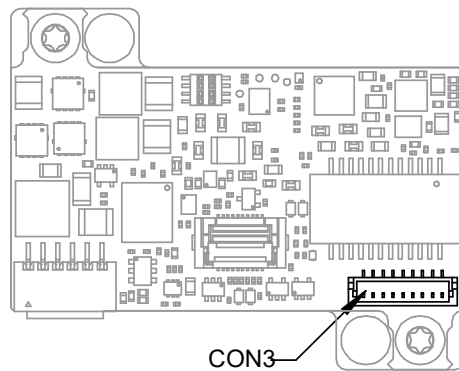

Fig. 4-4 Location of the FETK Ethernet Interface connector (CON3)

4.4 Power Supply

The FETK-S2.1 requires a permanent power supply. It is typically powered directly from the car battery. The input voltage may vary (see chapter 7.5 on page 39). In case of higher input voltages to the FETK, additional voltage protection is required.

The FETK-S2.1 will also accept voltage dips down to 3 V (for additional details of low voltage operation, see ISO standard 16750).

From the input battery voltage, switch-mode power supplies provide all necessary voltages on the FETK-S2.1. The power supply of the ECU is not affected by the FETK-S2.1. An automatic switch ensures that the power supply of the FETK-S2.1 is automatically switched on and off when the FETK enters and leaves its standby (sleep) mode.

The FETK-S2.1 is supplied with power through the connector CON2.

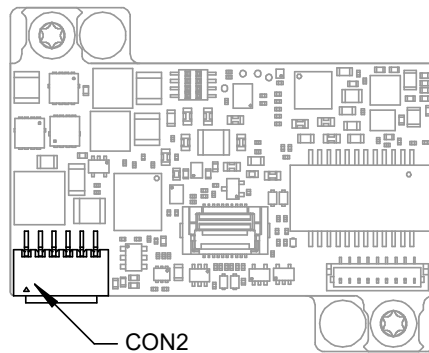

Fig. 4-5 Location of the FETK-S2.1 Power Supply Connectors

4.5 ECU Voltage Supervisor

The ECU voltage (VDDP) is monitored by the FETK to recognize whether the ECU is switched on or off. Additionally the ECU RAM standby voltage (VDDSB-
BRAM) is monitored to determine if the standby RAM content is still valid. These two signals are only used for monitoring therefore the load current is negligible.

NOTE

The FETK-S2.1 only allows switching between reference page and working page if there is a valid voltage at the sense pin and the working page has been initialized by the calibration and development system.

The FETK-S2.1 monitors the VDDSB-
BRAM supply on board the FETK. The micro-
controller's standby power supply pin must be connected to the FETK pin
VDDSB-
BRAM.

4.6 Data Emulation and Data Measurement

The FETK-S2.1 is a serial FETK using JTAG as the primary microcontroller interface. The interface can switch to LFAST during handshake. Typical of all serial ETKs, XETKs and FETKs, the RAM used for data emulation and data measurement is not accessible by the FETK until the microcontroller is powered up and the startup handshake is performed.

Serial FETKs use the ETAS two page concept, consisting of both a Reference and a Working page.

The Reference Page is located in the ECU flash and can not be modified by a simple write access. All changes to the Reference Page must be done via Flash programming.

The Working Page is located within the microcontroller's ED RAM. The Working Page may be a portion of or the entire size of the ED RAM. The ED RAM used for the emulation of calibration data must not be used by the ECU software directly as general purpose RAM. It is recommended that the ED RAM is permanently powered by the FETK or ECU. The FETK/INCA has the complete control over the RAM used as Working Page and its contents. When enabling data emulation, the FETK establishes a basic start-up configuration of the data in the Working Page by copying the corresponding data in the Flash to the emulation space.

To enable calibration, the Working Page must be activated. The process of switching from the Reference Page to the Working Page and vice versa is known as page switching.

The FETK-S2.1 supports Protocol Based page switching for all supported microcontrollers. Page switching is done in microcontroller software by switching the overlay memory on (Working Page) and off (Reference Page) using microcontroller overlay registers. The FETK-S2.1 does not directly control the microcontroller overlay registers. Instead the FETK-S2.1 and microcontroller software use a simple communication method with a shared mailbox in RAM. The FETK uses this mailbox to request and monitor page switching; the microcontroller software is responsible to service this mailbox and perform the page switches. Using an overlay modification description, also in RAM, the FETK provides the necessary information of how the overlay registers need to be modified to realize the page switch which is requested.

The FETK-S2.1 can access both the Reference Page and the Working Page, regardless of which is active from the microcontroller's point of view.

Another important restriction is that no access to the memory is possible, while the ECU is not running. To enable a cold start measurement in spite of this restriction, the cold start measurement procedure is defined to give the user the feeling of a parallel FETK.

4.7 JTAG and LFAST Interface

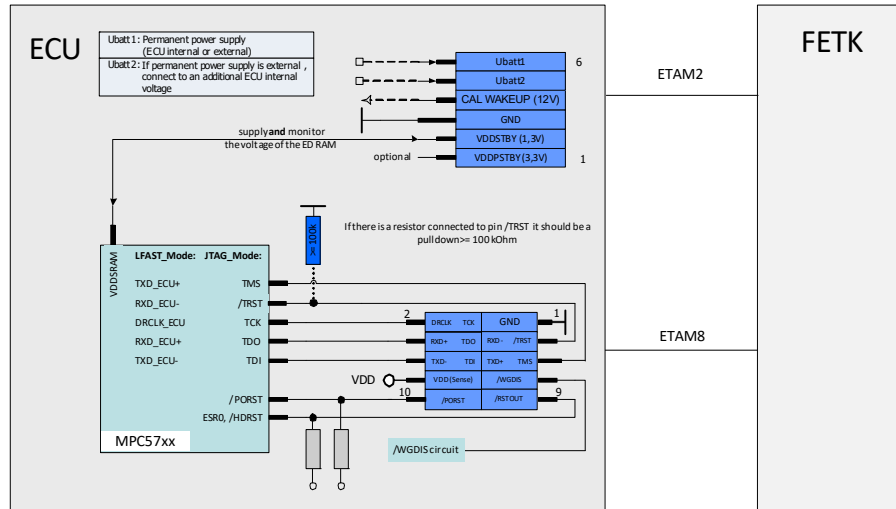

Fig. 4-6 Equivalent Circuitry of the ECU JTAG/ LFAST Interface (ECU)

4.7.1 Layout Recommendation for LFAST Mode

The wires /TRST, TDO should be closed together, with the same length, single ended impedance 500ohm.

The wires TMS, TDI should be closed together, with the same length, single ended impedance 500ohm

4.7.2 Debugger and MC Support

The FETK-S2.1 supports the JTAG mode for XCP debugger arbitration, test and calibration.

Mode	Debugger support	MC support
JTAG	Yes	Yes
LFAST	No	Yes

For LFAST mode the FETK-S2.1 starts at first in JTAG mode to switch into LFAST mode automatically.

4.8 Trigger Modes: Overview

The FETK-S2.1 supports the following trigger modes:

- Pinless triggering
- Timer triggering

The trigger mode "Pinless Triggering" uses the microcontroller's internal Development Trigger Semaphore (DTS) for triggering. See also chapter "Pinless Triggering" on page 25.

The trigger mode "Timer Triggering" uses four internal timers of the FETK for triggering. See also chapter "Timer Triggering" on page 26.

4.9 Pinless Triggering

4.9.1 Startup Handshake

The JTAG Data Communication (JDC) register is used to process the FETK startup handshake. The ECU must ensure that all memory ECC initialization has been completed prior to the start-up handshake.

For further information on ECC initialization, please refer to the microcontroller's reference manual.

4.9.2 FETK Trigger Generation

To generate triggers, the ECU software sets bits by writing the associated trigger index in the "DTS_SEMAPHORE 1 and 2" register.

 **NOTE**

The selective setting of trigger bits is accomplished in hardware by the microcontroller and does not require a Read-Modify-Write sequence by the ECU software.

Each bit of the "DTS_SEMAPHORE" corresponds to an FETK hardware trigger. Within the FETK's configuration and/or A2L file, bit 0 corresponds to hardware trigger 1 and bit 63 corresponds to hardware trigger 64.

 **NOTE**

Only the index 0 to 63 corresponding to the first 64 triggers are supported by the FETK-S2.1

The FETK periodically polls (reads) "DTS_SEMAPHORE" via JTAG. The polling rate is configurable, with 50 μ s default. The FETK then starts acquisition of appropriate measurement data based on which bits of the register are set.

Active bits in "DTS_SEMAPHORE" are automatically cleared by the microcontroller when the register is read by FETK.

4.10 Timer Triggering

The trigger mode "Timer Triggering" uses four internal timers of the FETK-S2.1 for triggering. A configurable period is used for triggering.

The time intervals between trigger events are in accordance with the configured timer values. These values and their resolution have to be defined in the FETK's configuration and/or A2L file. Available settings are:

- Minimum time interval 100 μ s
- Maximum period duration 1 s
- Timer resolution 1 μ s

The timers trigger the FETK in an asynchronous manner to the microcontroller software. Variables assigned to a measurement raster using a timer trigger are acquired from their original locations in RAM via JTAG.



NOTE

If variables are measured from ECC protected memories, the ECU software must ensure the proper initialization of these locations. A time-out period can be set in the FETK configuration to allow for the ECU to initialize the memories before the measurement begins.

4.11 Reset

The requirement for the FETK-S2.1 reset mechanism is to ensure that power-up and power-down behavior of ECU is clean and smooth.

The signals /PORST and /RESETOUT of the microcontroller are used by the FETK-S2.1 to detect when the ECU is in reset.

The FETK-S2.1 senses the switched ECU power supply. This allows it to detect when the ECU is off and forward this information to INCA. In addition, it allows the FETK to enter the power save mode with the calibration system unplugged.

4.12 Pull CalWakeUp until Startup Handshake

The FETK has the ability to wake up the ECU by applying voltage to the CalWakeUp pin of the ECU connector. This allows the FETK to configure a measurement while the ECU is off.

When waking up the ECU via the CalWakeUp pin, it can be configured if the pin is driven high until the microcontroller core voltage (VDDP) is high or if the pin should be driven high until the start-up handshake between ECU and FETK is complete.

5 Installation

This chapter contains information about the following topics:

- Mounting the FETK-S1.1 into the ECU Housing 30
- Connection to the ECU 33
- Wiring 34

5.1 Mounting the FETK-S2.1 into the ECU Housing



CAUTION

Some components of the interface board may be damaged or destroyed by electrostatic discharges. Please keep the board in its storage package until it is installed.

The board should only be taken from its package, configured, and installed at a work place that is protected against static discharge.



CAUTION

Risk of short circuiting the internal signals of the FETK!

When mounting the FETK to the ECU, ensure that the screws and washers used will not penetrate the FETK printed circuit board.

5.1.1 Thermal Connection Requirements

The FETK-S2.1 is assembled with a heatspreader and can be operate inside the metal ECU housing without cooling. To do this, there must be a distance of a few millimeters between the FETK-S2.1 heat spreader and the ECU housing.

A thermal connection (completely or partially) from the FETK heat spreader to the ECU housing should be preferred.



CAUTION

Risk of overheating the FETK-S2.1!

To avoid overheating of the FETK-S2.1 the connection to the ECU housing following requirements for thermal conductivity must be met:

- ECU housing thermal conductivity at the FETK-S2.1 mounting position: $>2.5 \text{ W}/(\text{m} \cdot \text{K})$, guaranteed by size and material of the ECU housing and
- heat conductive paste thermal conductivity: $>0.75 \text{ W}/(\text{m} \cdot \text{K})$.

5.1.2 Mounting Material

To mount the FETK-S2.1 to the ECU housing several materials are required:

- FETK-S2.1
- ECU metal housing with machined holes aligning with FETK-S2.1 hole pattern (see chapter "Mechanical Dimensions" on page 55
- Heat conductive paste with a thermal conductivity $> 0.75 \text{ W}/(\text{m} \cdot \text{K})$

- Two screws M2.5
 - cylinder head, countersunk-, self-sealing screw
 - length depending on the ECU project:
(\geq [2.5 mm to 4 mm] + wall thickness ECU housing)
- Screwdriver T8

5.1.3 Mounting Steps

To mount the FETK-S2.1 to the ECU housing several mounting steps are required:

Preparing the ECU Housing

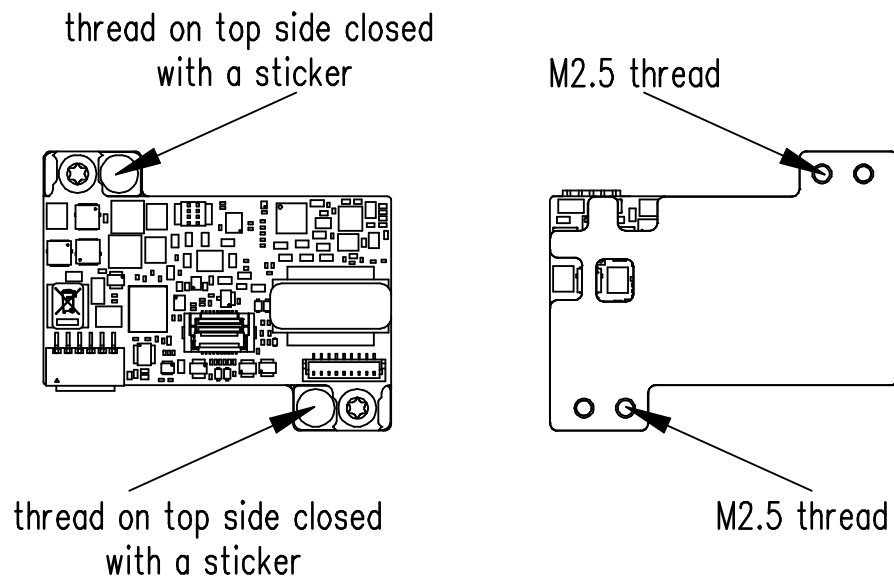

Fig. 5-1 FETK-S2.1 Threads and Heat Spreader

1. Drill two holes in the ECU housing.

i NOTE

Use the Fig. 7-7 on page 49 as a drilling template to prepare the ECU housing with machined holes aligning with FETK-S2.1 hole pattern.

Preparing the FETK-S2.1

2. Apply a thin layer of heat conductive paste to the bottom side of the FETK-S2.1 heat spreader.

Attaching the FETK-S2.1 to the ECU Housing

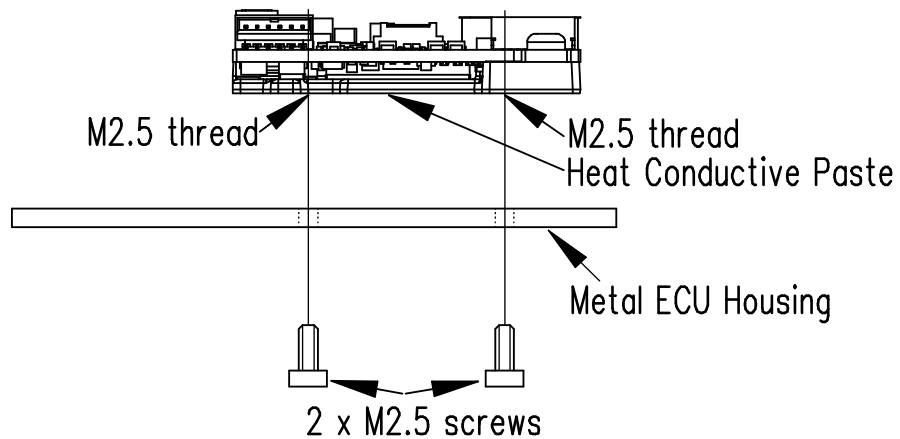

Fig. 5-2 Attaching the FETK-S2.1 to the ECU

1. Align the threaded drill holes of the FETK-S2.1 to the openings in the ECU housing.
2. Insert the screws into the holes in the ECU housing.
3. Screw the screws into the FETK-S2.1.



NOTE

Screw the two parts together without getting them off-thread.



NOTE

Screw the FETK-S2.1 onto the ECU housing using exclusively M2.5 screws and a max. torque of 0.9 Nm.

The FETK-S2.1 and the ECU housing are now connected mechanically.

5.2 Connection to the ECU



CAUTION

Risk of short circuiting the internal signals of the FETK!

When you mount the FETK to the ECU, you must ensure that the screws and washers used will not penetrate the FETK printed circuit board.

For connecting the FETK-S2.1 to the ECU two FETK adapter cables are recommended:

- at CON1 adapter cable ETAM8
- at CON2 adapter cable ETAM2 or ETAM5

For additional details to connect the FETK-S2.1 to the ECU with adapter cables see Fig. 5-4.

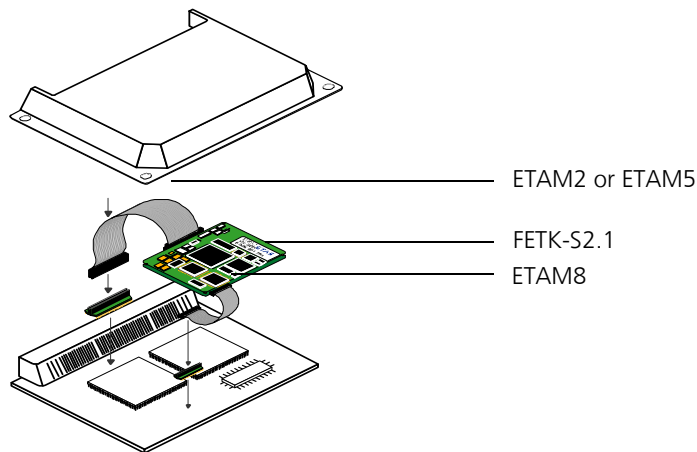

Fig. 5-3 FETK-S2.1 Connection to the ECU

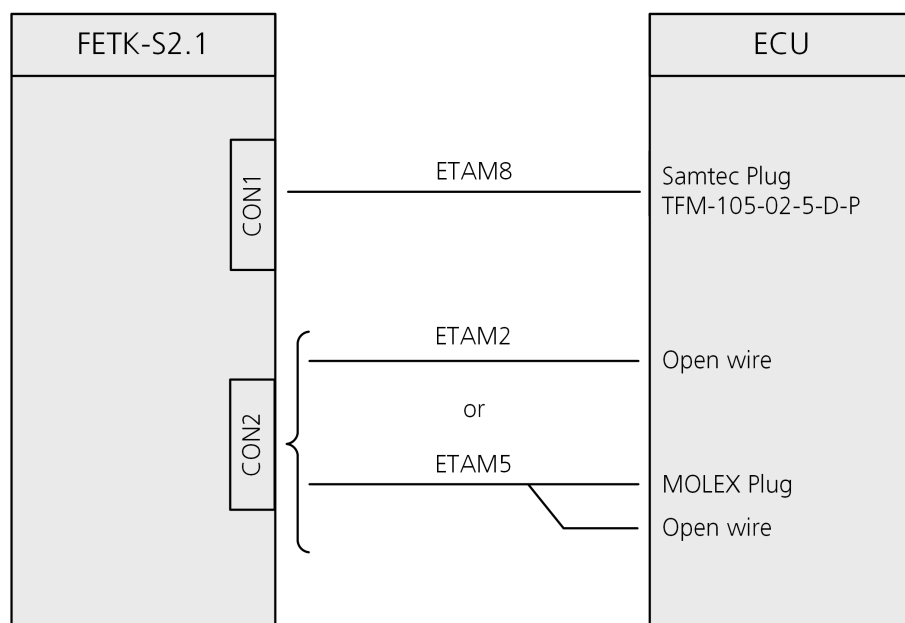

Fig. 5-4 FETK-S2.1 Connection to the ECU

5.3 Wiring

5.3.1 FETK Ethernet Interface

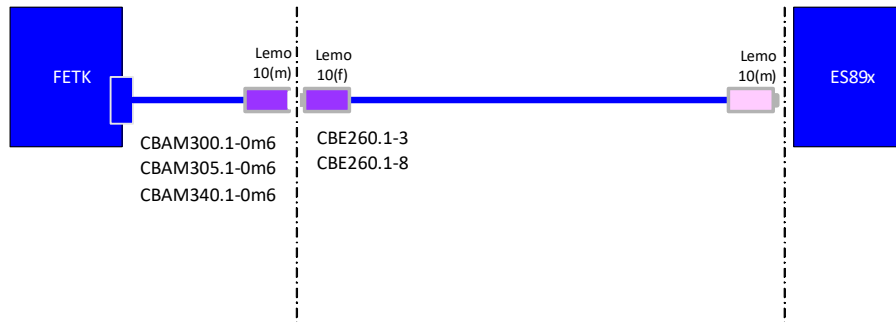

Fig. 5-5 Wiring - FETK Ethernet Interface

The FETK Ethernet interface can be connected to the ES89x ECU and Interface Module.



NOTE

The FETK Ethernet interface utilizes a proprietary Ethernet protocol and is compatible only with the Gigabit Ethernet interfaces of the ES89x ECU Interface Module.

5.3.2 Power Supply

The FETK-S2.1 needs a permanent power supply.

5.3.2.1 Permanent Power Supply inside ECU available

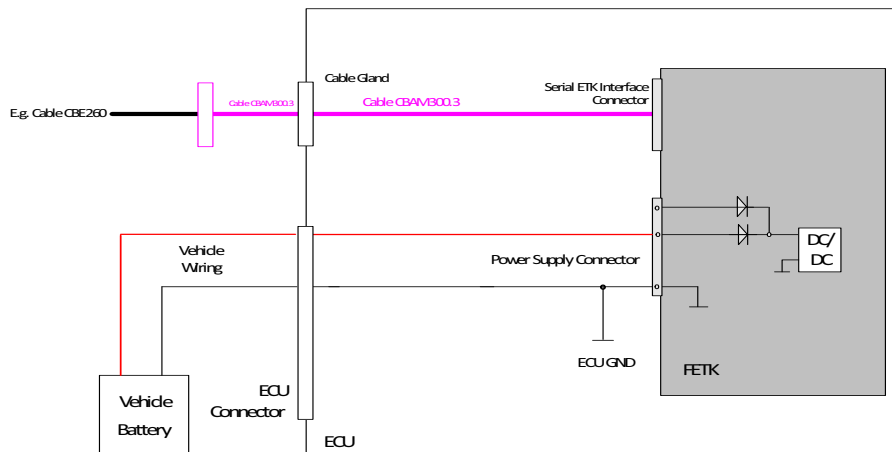

Fig. 5-6 FETK-S2.1 Power Supply wiring with CBAM300.3 Cable

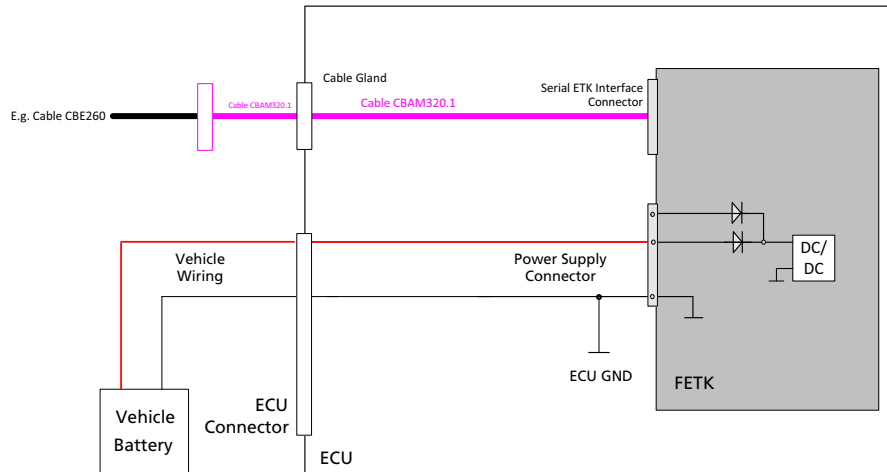

Fig. 5-7 FETK-S2.1 Power Supply wiring with CBAM320.1 Cable

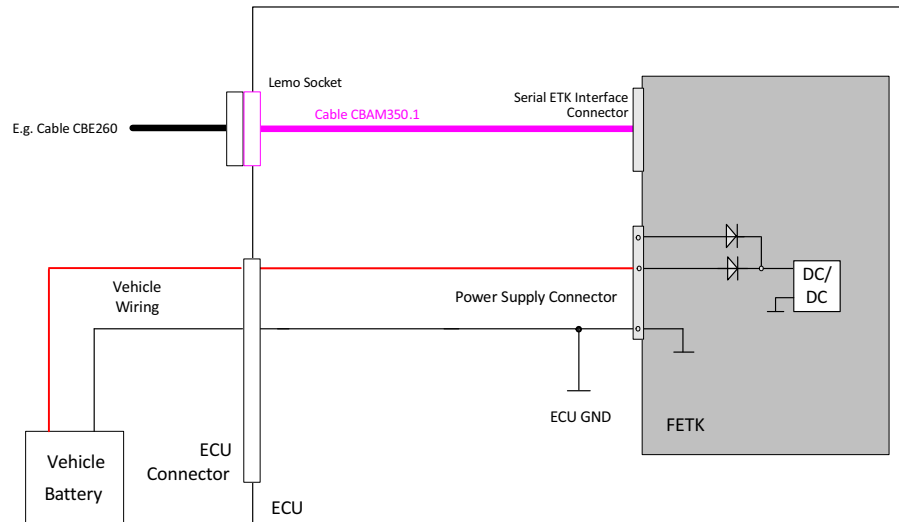

Fig. 5-8 FETK-S2.1 Power Supply wiring with CBAM350.1 Cable

5.3.2.2 Permanent Power Supply inside ECU not available

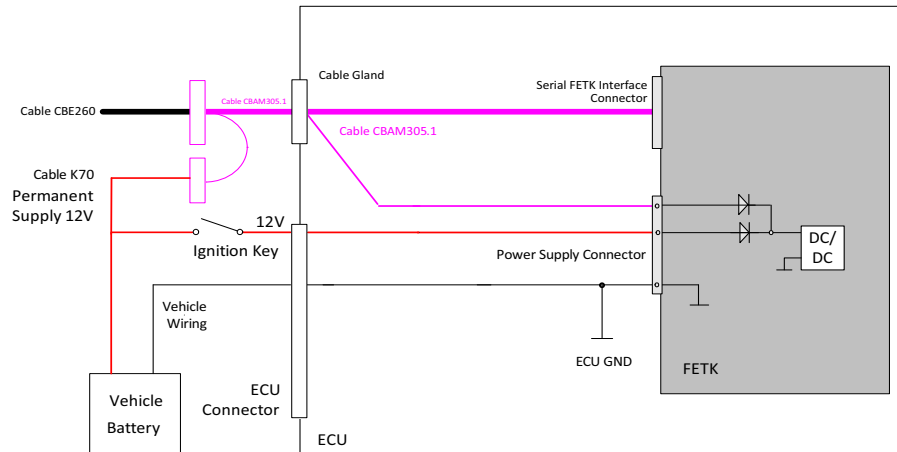

Fig. 5-9 FETK-S2.1 Power Supply wiring with CBAM305.1 Cable

5.3.2.3 Isolated Power Supply inside ECU

The FETK-S2.1 does not require a galvanically isolated power supply. For special applications ETAS can offer a isolated power supply unit.

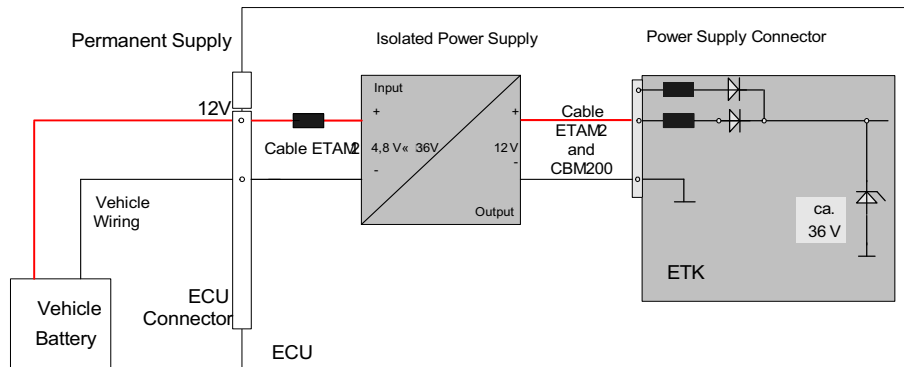

Fig. 5-10 Isolated Power Supply inside ECU

6 ETK / XETK / FETK Configuration

This chapter contains information about the following topics:

- Overview 34
- Configuration Parameter 35

6.1 Overview

As already mentioned in previous chapters, some project-specific adjustments are necessary. Configuration data is stored permanently in a serial Flash.

Generating a valid configuration data set is supported by the ETK / XETK / FETK Configuration Tool (XCT). The XCT contains information on all available ETKs, XETKs, and FETKs. The user is supported through a graphical interface.

The configuration is done in two steps:

1. Generation of the special address offset for the emulation and measurement data memory.

The location of data areas, measured data output areas, trigger segment addresses etc. are familiar to the ECU software developer, or can be generated automatically. If an ECU description database (ASAP, ...) with the corresponding input exists, these inputs can be downloaded from this database. If necessary, a plausibility check is performed.

2. Connection of the ETK / XETK / FETK to the ECU.

The ECU hardware developer defines the connection of the ETK / XETK / FETK to the ECU. The corresponding signals usually have to be adjusted for each microcontroller. All inputs are checked for plausibility, to make sure that a valid configuration is generated.

The XCT can create the following output:

- Direct ETK / XETK / FETK configuration
- Storage of the configuration in a data file
- The corresponding ASAP2 input

The most important outputs are the entries for the ASAP2 file. All A2L definitions necessary for configuring an ETK / XETK / FETK will be created. These are:

- Overlay Region definitions
- Memory Segment definitions
- ETK / XETK / FETK configuration features
- Raster definitions

If these parameters are entered correctly in the corresponding ECU description file, it guarantees that every time the calibration system is started, the ETK / XETK / FETK is checked for the appropriate configuration.

If necessary, the ETK / XETK / FETK will be configured appropriately to the corresponding project.

6.2 Configuration Parameter

The XCT provides support concerning hardware configuration parameters and their possible values.

They are described for the different ETK / XETK / FETK types in the help document of the XCT.

Starting the XCT help

1. Start XCT.

The main window of XCT opens.

2. Select in the menu bar **? > Contents**.

The XCT help window opens.

3. Choose **Reference to User Interface > (X)ETK Hardware Configuration Parameters**.

4. Choose the topic **FETK-S2.1**.

The topic **FETK-S2.1** contains information about the FETK-S2.1 hardware configuration parameters and their possible values.

7 Technical Data

This chapter contains information about the following topics:

- System Requirements 36
- Data Emulation and Measurement Memory 37
- FETK Ethernet Interface 38
- Environmental Conditions 38
- Power Supply 39
- Test Characteristics 39
- JTAG Timing Characteristics 40
- Electrical Characteristics 41
- Pin Assignment 44
- Mechanical Dimensions 48

7.1 System Requirements

7.1.1 ETAS Compatible Hardware

ETAS Hardware: ES89x ECU Interface Modules

7.1.2 PC with one Ethernet Interface

A PC with one open Ethernet interface (1 Gbit/s) with RJ45 connection is required. Ethernet interfaces that are implemented with an additional network card in the PC must feature a 32-bit data bus.

7.1.2.1 Requirement to ensure successful Initialization of the Module



NOTE

It is imperative you disable the function which automatically switches to power-saving mode on your PC network adapter when there is no data traffic on the Ethernet interface!

To deactivate the power saving mode

Choose in Windows System Control Center / Device Manager / Network Adapter the used network adapter by double-click. Deactivate the "Allow the computer to turn off this device to save power" option in the "Power Management" register. Confirm your configuration.

The manufacturers of network adapter have different names for this function.

Example:

- "Link down Power saving"
- "Allow the computer to turn off this device to save power"

7.1.3 Software Support

You need following software versions to support the FETK-S2.1:

Microcontroller	HSP	INCA	ETK Tools	ASCET-RP	INTECRIO
MPC5746MED EMU57EM80xy	V11.8.0	V7.2.8	V4.1.9	V6.4.3	V4.6.2
MPC5746M / SPC57EM80xy	V11.8.0	V7.2.8	V4.1.9	V6.4.3	V4.6.2
MPC5744K-ED / EMU574K72xy	V11.8.0	V7.2.8	V4.1.9	V6.4.3	V4.6.2
MPC5744K / SPC574K72xy	V11.8.0	V7.2.8	V4.1.9	V6.4.3	V4.6.2
MPC5777A-ED / EMU57HM90xy	V11.8.0	V7.2.8	V4.1.9	V6.4.3	V4.6.2
MPC5777A / SPC57HM90xy	V11.8.0	V7.2.8	V4.1.9	V6.4.3	V4.6.2
MPC5746R-ED ¹⁾	V11.8.0	V7.2.8	V4.1.9	V6.4.3	V4.6.2
MPC5746R	V11.8.0	V7.2.8	V4.1.9	V6.4.3	V4.6.2
SPC58NN84	V11.8.0	V7.2.8	V4.1.9	V6.4.3	V4.6.2
EMU58NE84	V11.13.0	V7.2.13	V4.1.14	V6.4.3	V4.6.2
SPC58xG	V11.13.0	V7.2.13	V4.1.14	V6.4.3	V4.6.2

¹⁾: In case offline-BIST is used, this is only supported with Rainier Cut2.0B (not supported with Cut1.0/2.0/2.1)

Operating the FETK-S2.1 with older software versions is not possible.

MPC57xx: NXP / Freescale microcontroller device

EMU57xx: STMicroelectronics microcontroller device

The configuration instructions for the FETK-S2.1 under INCA and HSP are contained in the relevant software documentation.

7.2 Data Emulation and Measurement Memory

7.2.1 Data Emulation Memory and Microcontroller Support

The FETK-S2.1 uses a portion of or up to the entire size of the ED RAM, to emulate data in internal flash. The following table lists the supported microcontrollers, the size of the ED RAM, and states if the ED RAM is capable of being powered using a standby supply.

Microcontroller	Max. ED RAM	Standby powered
MPC5746MED	1 Mbyte (32 x 32 KByte)	Yes
EMU57EM80xy	1 Mbyte (32 x 32 KByte)	Yes
MPC5777MED	2 Mbyte (32 x 64 KByte)	Yes
EMU57HM90xy	2 Mbyte (32 x 64 KByte)	Yes
MPC5744K	1 Mbyte (32 x 32 KByte)	Yes

Microcontroller	Max. ED RAM	Standby powered
EMU574K72xy	1 Mbyte (32 x 32 KByte)	Yes
MPC5746RED	1 Mbyte (32 x 32 KByte)	Yes
SPC/EMU58NN84	2 Mbyte (32 x 64 KByte)	Yes
EMU58NE84	2 Mbyte (32 x 64 KByte)	Yes

7.2.2 Measurement Data Memory

Item	Characteristics
Location	Typically located within the emulation memory when using DISTAB17 hooks. Measurement data memory can be located in internal RAM if the entire ED RAM is needed for calibration.
Update	Logic devices updated using HSP software

7.3 FETK Ethernet Interface

Item	Characteristics
Connection	1 Gbit/s Ethernet
Cable length	max. 30 m / 100 ft
Ethernet Interface	DC decoupling

NOTE

The FETK Ethernet interface utilizes a proprietary Ethernet protocol and is compatible only with the Gigabit Ethernet interfaces of the ES89x ECU Interface Module.

7.4 Environmental Conditions

Item	Characteristics
Temperature range (operation)	- 40 °C to +110 °C/ - 40 °F to +230 °F
Temperature range (storage)	0 °C to +50 °C/ - 18 °F to +122 °F
Relative humidity (non-condensing)	0 to 95%
Operating altitude	max. 5000 m/ 16400 ft
Contamination level	2
Degree of protection	Determined by installation in ECU
Overvoltage category (AC mains supply)	II

7.5 Power Supply

Parameter	Symbol	Condition	Min	Typ	Max	Unit
Permanent power supply (car battery)	U_{Batt}	Vehicle usage ¹⁾	6.0	12	36	V
[all values $\pm 0\%$]						
Cranking Voltage	U_{Batt}	< 3 seconds	3			V
Standby current	I_{STBY}	$U_{Batt} = 12\text{ V}$; ECU off; no load from ECU; $T = 20\text{ }^\circ\text{C}$	10	16	25	mA
Operating current	I_{Batt}	$U_{Batt} = 12\text{ V}$; no load from ECU; $T = 20\text{ }^\circ\text{C}$	50	95	170	mA
Power consumption	P_{Batt}	$U_{Batt} = 12\text{ V}$; $I = 0\text{ mA}$ at pin ECU_SBRAM; $T = 20\text{ }^\circ\text{C}$		1.14		W
Power consumption	P_{Batt}	$U_{Batt} = 12\text{ V}$; $I = 500\text{ mA}$ at pin VDDSTBY [1.25 V]; $I = 80\text{ mA}$ at Pin VDDPSTBY; $T = 20\text{ }^\circ\text{C}$		2.4		W

¹⁾ The FETK-S2.1 implements reverse voltage protection in the same range and may be used only with central load dump protection.
24 V vehicles require U_{Batt} disturbing pulse reduction to 12 V vehicle system.
12 V vehicles don't require special disturbing pulse reductions.

NOTE

The FETK-S2.1 will accept permanent power supply voltage dips (for additional details of 3 V low voltage operation, see ISO standard 16750).

7.6 Test Characteristics

Parameter	Symbol	Condition	Min	Typ	Max	Unit
Start Up Time 1 ¹⁾	$t_{startup1}$	$U_{Batt} = 12\text{ V}$ ECU_VDDP goes high	0		6	ms
Start Up Time 2 ¹⁾	$t_{startup2}$	U_{Batt} goes high	180		670	ms

¹⁾ /PORST is not pulled low until FETK start up time

7.7 JTAG Timing Characteristics

The following diagrams show the timings the FETK-S2.1 can process.

NOTE

JTAG timing parameters in this chapter refer to the JTAG interface (CON1) of the FETK-S2.1. The JTAG wiring to the ECU (ETAM8) must be taken into account additionally.

All timings are measured at a reference level of 1.5 V. Output signals are measured with 20 pF to ground and 50 Ω to 1.5 V.

7.7.1 JTAG Timing Diagram

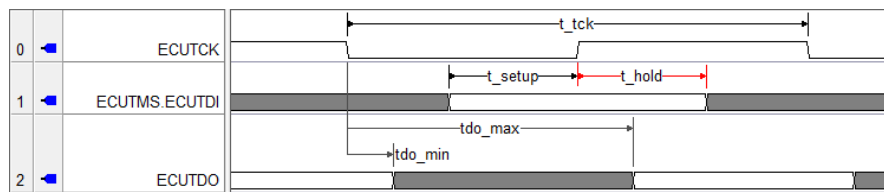

7.7.2 JTAG Timing Parameters

Parameter	Symbol	Value [ns]	Comment
JTAG Clock Period (ETK → Target)	t_{tck}	50	20 MHz Nexus JTAG Clock Frequency
		25	40 MHz Nexus JTAG Clock Frequency
		20	50 MHz Nexus JTAG Clock Frequency
TMS/TDI Set-Up Time (ETK → Target)	t_{setup}	7 (min.)	Minimum 5 ns required for microcontroller
TMS/TDI Hold Time (ETK → Target)	t_{hold}	7 (min.)	Minimum 5 ns required for microcontroller
TDO clock-to-out time (Target → ETK)	t_{do_min}	2.25 (min.)	Minimum 2.25 ns required by microcontroller specification
	t_{do_max}	16 (max)	Maximum 16 ns by microcontroller specification

7.8 Electrical Characteristics

7.8.1 ECU Interface Characteristics

Parameter	Symbol	Condition ¹⁾	Min	Typ	Max	Unit
ECU Standby RAM Output Voltage	VDDSTBY	max. 500 mA load	1.21	1.26	1.3	V
VDDPSTBY Output Voltage	VDDPSTBY	max. 80 mA load	3.14	3.3	3.46	V
Cal_Wakeup Output Voltage	CAL_WAKEUP	Ubatt = 6 V to 36 V, load = 0 to 50 mA	Ubatt - 1 V		Ubatt	V
ECU Power Supply Supervision Voltage (3.3 V selected)	VDDP	ECU on	2.67	2.77	2.89	V
		ECU off	2.44	2.56	2.68	V
	IDDP	VDDP = 3.3 V			800	μA
ECU Standby RAM Supervision Voltage (1.25 V selected)	VDDSTBY / VDDSTBY_SENSE	VDDSTBY ↑	1.03	1.07	1.1	V
		VDDSTBY ↓	1.02	1.06	1.08	V
	IDDSTBY	VDDSTBY = 1.25 V			50	μA

¹⁾: VDDP ↑: ECU Power Supply off → ECU Power Supply on
 VDDP ↓: ECU Power Supply on → ECU Power Supply off
 VDDSTBY ↑: ECU Standby RAM Power off → ECU Standby RAM Power on
 VDDSTBY ↓: ECU Standby RAM Power on → ECU Standby RAM Power off

7.8.2 ECU Interface Connector CON1

7.8.2.1 JTAG Mode (5 V Interface selected)

Signal	Pin Type	V _{OL} (max) [V]	V _{OH} (min) [V]	V _{OH} (max) [V]	V _{IL} (max) [V]	V _{IH} (min) [V]	V _{IH} (max) [V]	Leakage current [μA]	Additional Load by ETK (typ) [pF] ¹⁾
TCK	XO ²⁾	0.7	3.8	5.2	-	-	6.5	+1135/ +810	15
TMS	XO ²⁾	0.7	3.8	5.2	-	-	6.5	+60/ -60	25
TDO	I	-	-	-	0.8	2	6.5	+50/ -50	27
TDI	XO ²⁾	0.7	3.8	5.2	-	-	6.5	+40/ -40	21
/TRST	XO ²⁾	0.7	3.8	5.2	-	-	6.5	+40/ -40	23
/ESR0	IXOD ³⁾	0.7	-	-	0.8	2	6.5	+25/ -20	15
/PORST	IXOD ³⁾	0.7	-	-	0.8	2	6.5	+25/ -20	15
WDGDIS	XO ²⁾	0.7	3.8	5.2	-	-	6.5	+10/ -10	10

1) Adapter cable and Samtec connector not considered; PCB 1 pF/cm

2) I_{Dmax} = 12 mA

3) Open Drain FET; I_{Dmax} = 0.2 A

I: Input

X: Tristate

O: Output

OD: Open Drain

7.8.2.2 JTAG Mode (3.3 V Interface selected)

Signal	Pin Type	V_{OL} (max) [V]	V_{OH} (min) [V]	V_{OH} (max) [V]	V_{IL} (max) [V]	V_{IH} (min) [V]	V_{IH} (max) [V]	Leakage current [µA]	Additional Load by ETK (typ) [pF] ¹⁾
TCK	XO ²⁾	0.7	2.4	3.45	-	-	6.5	+730/ +470	15
TMS	XO ²⁾	0.7	2.4	3.45	-	-	6.5	+60/ -60	25
TDO	I	-	-	-	0.8	2	6.5	+50/ -50	27
TDI	XO ²⁾	0.7	2.4	3.45	-	-	6.5	+40/ -40	21
/TRST	XO ²⁾	0.7	2.4	3.45	-	-	6.5	+40/ -40	23
/ESR0	IXOD ³⁾	0.7	-	-	0.8	2	6.5	+25/ -20	15
/PORST	IXOD ³⁾	0.7	-	-	0.8	2	6.5	+25/ -20	15
WDGDIS	XO ²⁾	0.7	2.4	3.45	-	-	6.5	+10/ -10	10

¹⁾ Adapter cable and Samtec connector not considered; PCB 1 pF/cm

²⁾ $I_{Dmax} = 12$ mA

³⁾ Open Drain FET; $I_{Dmax} = 0.2$ A

I: Input

X: Tristate

O: Output

OD: Open Drain

7.8.2.3 LFAST Mode

Signal	Pin Type	V_{IL} (max) [V]	V_{IH} (min) [V]	V_{IH} (max) [V]	V_{ID} (min) [mV]	V_{ID} (max) [mV]	V_{OD} (min) [mV]	V_{OD} (max) [mV]	Additional Load by ETK (typ) [pF] ¹⁾
DRCLK	I	0.8	2	6.5	-	-	-	-	15
TXD+/-	I	-	-	-	50	1000	-	-	10
RXD+/-	XO	-	-	-	-	-	400	550	-

¹⁾ Adapter cable and Samtec connector not considered; PCB 1 pF/cm

I: Input

X: Tristate

O: Output

7.9 Pin Assignment

NOTE
 The tables describes the pin assignment at the ETK side.

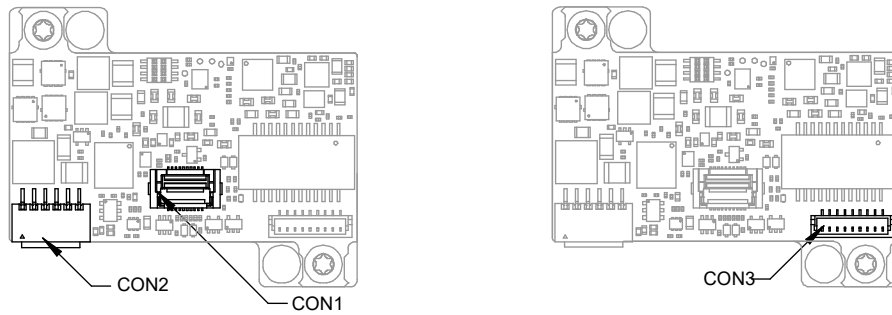

Fig. 7-1 Location of the FETK-S2.1 Interfaces

7.9.1 ECU Interface Connector CON1

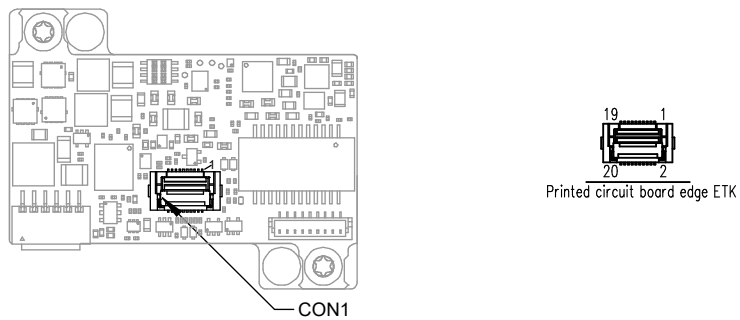

Fig. 7-2 ECU Interface Connector CON1

7.9.1.1 ECU Interface (JTAG Mode)

Pin	Signal	Direction	Comment
1	TCK	Output	JTAG signal
2	/TRST	Output	JTAG signal
3	GND	Power	Signal ground
4	TDO	Input	JTAG signal
5	WDGDIS	Output	Watchdog disable signal
6	GND	Power	Signal ground
7	VDDP (Sense)	Input	Sense for switched power supply of ECU (ignition)
8	TMS	Output	JTAG signal
9	GND	Power	Signal ground
10	TDI	Output	JTAG signal
11	/ESR0	Bidir	ECU reset signal (open drain) for reset assertion and supervision
12	GND	Power	Signal ground
13	/PORST	Bidir	ECU Power On Reset signal (open drain) for Reset assertion and supervision
14	DNU	Output	DNU, Mfr test signal
15	NC		Not connected
16	DNU	Output	DNU, Mfr test signal
17	NC		Not connected
18	GATE_PORST	Input	Input Overwrite /PORST status at Power On
19	NC		Not connected
20	GND	Power	Signal ground

7.9.1.2 ECU Interface (LFAST Mode)

Pin	Signal	Direction	Comment
1	DRCLK	Input	LFAST signal
2	RXD-	Output	LFAST differential input
3	GND	Power	Signal ground
4	RXD+	Output	LFAST differential input
5	WDGDIS	Output	Watchdog disable signal
6	GND	Power	Signal ground
7	VDDP (Sense)	Input	Sense for switched power supply of ECU (ignition)
8	TXD+	Input	LFAST differential input
10	TXD-	Input	LFAST differential input
11	/RESETOUT	Bidir	ECU reset signal (open drain) for reset assertion and supervision
12	GND	Power	Signal ground
13	/PORST	Bidir	ECU Power On Reset signal (open drain) for Reset assertion and supervision
14	DNU	Output	DNU, Mfr test signal
15	NC		Not connected
16	DNU	Output	DNU, Mfr test signal
17	NC		Not connected
18	GATE_PORST	Input	Input Overwrite /PORST status at Power On
19	NC		Not connected
20	GND	Power	Signal ground

7.9.2 Power Supply Connector CON2

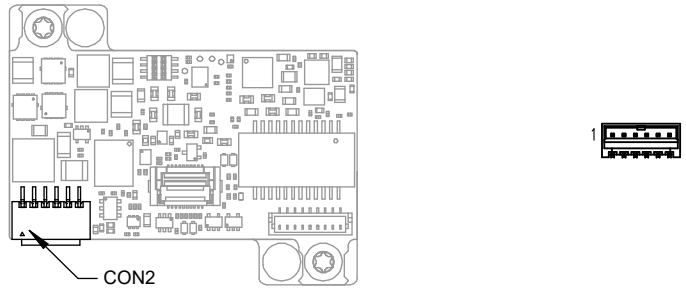

Fig. 7-3 Power Supply Connector CON2

Pin	Signal	Direction	Comment
1	VDDPSTBY (3.3 V supply)	Output	Permanent power supply of ECU JTAG interface, 3.3 V
2	VDDSTBY (1.25 V supply)	Output	Permanent power supply of ECU EDRAM, 1.25 V
3	GND	Input	Power GND
4	CalWakeup	Output	Switch to Ubatt. ECU wake-up signal (for measurement preparation)
5	Ubatt2	Input	Vehicle battery
6	Ubatt1	Input	Vehicle battery

NOTE

VDDSTBY may not be used as power supply of the microcontroller core. VDDSTBY is permanently available and must be used as power supply of the EDRAM, only.

7.9.3 FETK Ethernet Interface Connector CON3

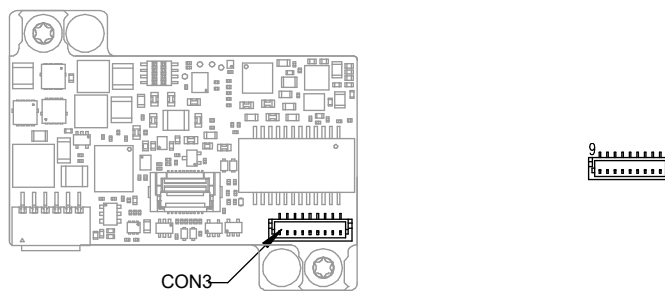

Fig. 7-4 FETK Ethernet Interface Connector CON3

7.10 Mechanical Dimensions

The reference measure for all drawings is millimeters.

Item	Dimension [Millimeters]	Dimension [Inches]
Length	46.0	1.811
Width	37.0	1.4567
Height ¹⁾	13.1	0.5157

¹⁾: CBAM300/ CBAM305/ CBAM340 mounted at CON3

7.10.1 Top View

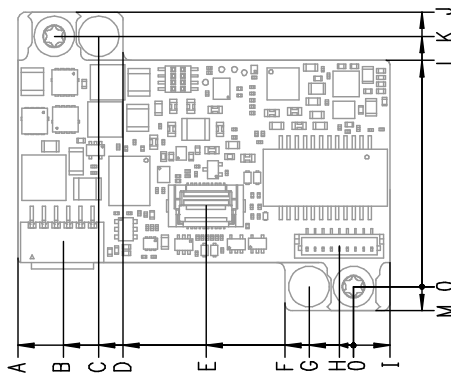

Fig. 7-5 FETK-S2.1 Dimensions - Top View

Item	Dimension [Millimeters]	Tolerance [Millimeters]	Dimension [Inches]	Tolerance [Inches]
A	41.50	+/- 0.20	1.634	+/- 0.008
B	35.90	+/- 0.30	1.413	+/- 0.012
C	31.50	+/- 0.10	1.240	+/- 0.004
D	28.50	+/- 0.20	1.122	+/- 0.008
E	20.90	+/- 0.30	0.823	+/- 0.012
F	8.50	+/- 0.20	0.335	+/- 0.008
G	5.50	+/- 0.10	0.217	+/- 0.004
H	1.75	+/- 0.20	0.069	+/- 0.008
I	4.50	+/- 0.20	0.177	+/- 0.008
J	34.00	+/- 0.20	1.339	+/- 0.008
K	31.00	+/- 0.10	1.220	+/- 0.004
L	28.00	+/- 0.20	1.102	+/- 0.008
M	3.00	+/- 0.20	0.118	+/- 0.008

7.10.2 Side View

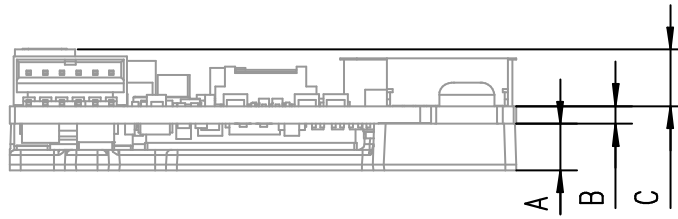

Fig. 7-6 FETK-S2.1 Dimensions - Side View

Item	Dimension [Millimeters]	Tolerance [Millimeters]	Dimension [Inches]	Tolerance [Inches]
A	4.20	+/- 0.10	0.165	+/- 0.004
B	1.60	+/- 0.16	0.063	+/- 0.006
C	5.10	+0.0 -0.2	0.201	+0.000 -0.008

8 Cables and Accessories

8.1 Overview and Classification

This chapter contains information about the following topics:

- ECU Adapter Cable
 - “CBAM300 Cable” on page 51
 - “CBAM320 Cable” on page 52
 - “CBAM340 Cable” on page 53
 - “CBAM350 Cable” on page 54
- ECU Adapter and Power Supply Cable
 - “CBAM305 Cable” on page 56
- GBit Ethernet and Power Supply Cable
 - “CBE260 Cable” on page 59
- ECU Adapter
 - “ETAM8 Adapter” on page 60
- Power Supply Cable
 - “ETV5 Cable” on page 62
 - “ETAM2 Adapter” on page 63
 - “ETAM5 Adapter” on page 64
 - “ETAM9 Adapter” on page 65
 - “ETAM10 Adapter” on page 66

8.2 Requirements for failsafe Operation

 **NOTE**

See chapter “Connection to the ECU” on page 30 for details on wiring the ECU interface adapters.

 **NOTE**

We recommend to use ETAS cables or any other cables certified by the standards for the application. Adhere to the maximum permissible cable lengths!

 **NOTE**

Application-specific cables are available from ETAS. Please contact your ETAS contact partner or e-mail sales.de@etas.com.

8.3 CBAM300 Cable

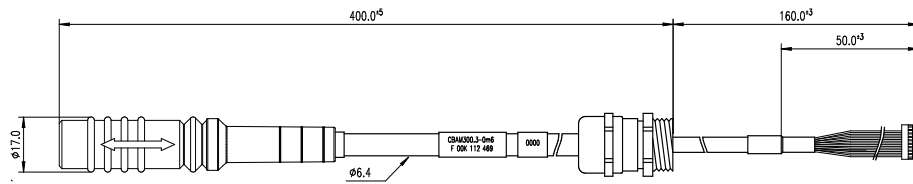

Fig. 8-1 CBAM300.3 Cable - Dimensions

8.3.1 Usage

The FETK ECU interface cable CBAM300.3 is pre-assembled into PG9 screwing, with a connected shield on screwing:

- For thin walled housings, use a through boring with 15.2 mm in the housing and mount the cable with a nut (not included) (SM-PE 9 order number 52103210 from Lapp).
- For wall thickness more than 4 mm cut a thread into the housing.

8.3.2 Connectors

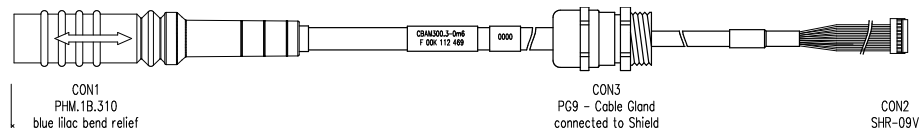

Fig. 8-2 CBAM300.3 Cable - Connectors

Connector	Color	Target
CON1	Blue lila	Gbit Ethernet cable, e.g. CBE260
CON2	White	FETK
CON3		Shield ECU housing

8.3.3 Temperature Range

Condition	Temperature
Operating temperature	-40 °C to +125 °C

8.3.4 Tightness

Condition	IP Code
PG9 screwing	IP67

8.3.5 Ordering

Product	Length	Order Number
CBAM300.3-0m6	0.6 m	F 00K 112 469

8.4 CBAM320 Cable

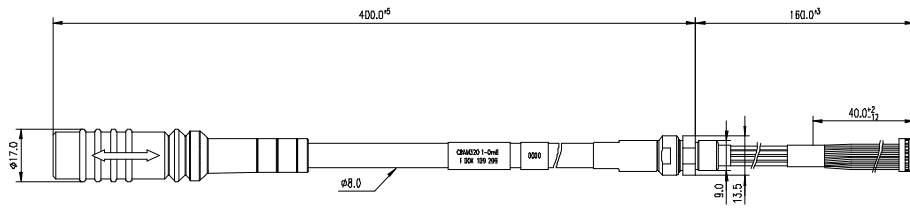

Fig. 8-3 CBAM320 Cable - Dimensions

8.4.1 Usage

The CBAM320.1-0m60 ETK interface cable is a 1 GBit/s cable adapter for FETKs. It is pre-assembled into M9 screwing, shield connected to the screwing:

- For wall thickness less than 4 mm, it is possible to use a through boring with 9.2 mm in the housing and mount the cable with a nut (included).
- For wall thickness more than 4 mm cut a thread into the housing. A special Lemo thread cutter is necessary.

8.4.2 Connectors

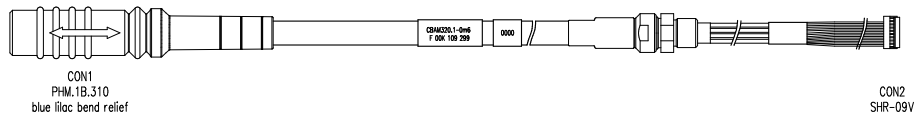

Fig. 8-4 CBAM320 Cable - Connectors

Connector	Color	Target
CON1	Blue lila	Gbit Ethernet cable, e.g. CBE260
CON2	White	FETK

8.4.3 Temperature Range

Condition	Temperature
Operating temperature	-40 °C to +125 °C

8.4.4 Tightness

Condition	IP Code
PG8 screwing	IP67

8.4.5 Ordering

Product	Length	Order Number
CBAM320.1-0m6	0.6 m	F 00K 109 299

8.5 CBAM340 Cable

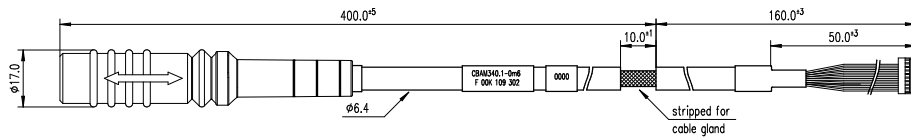

Fig. 8-5 CBAM340 Cable - Dimensions

8.5.1 Usage

The FETK interface cable CBAM340.1 is stripped for 10 mm, to mount the cable with a EMC safe cable gland into the ECU housing.

FETK ECU Adapter Cable, shield on ECU-Housing

NOTE

The hardware for mounting ECU adapter cables is not included in the cable delivery, they need to be ordered separately. For detailed information on mounting accessories contact ETAS technical support.

8.5.2 Connectors

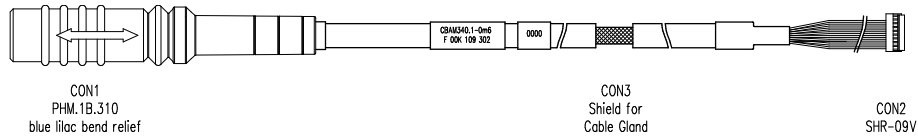

Fig. 8-6 CBAM340 Cable - Connectors

Connector	Color	Target
CON1	Blue lila	Gbit Ethernet cable, e.g. CBE260
CON2	White	FETK
CON3	-	Shield to ECU housing

8.5.3 Temperature Range

Condition	Temperature
Operating temperature	-40 °C to +125 °C

8.5.4 Ordering

Product	Length	Order Number
CBAM340.1-0m6	0.6 m	F 00K 109 302

8.6 CBAM350 Cable

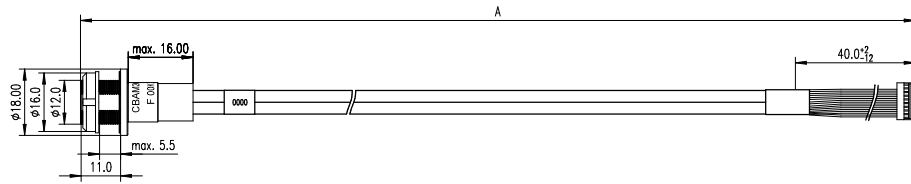

Fig. 8-7 CBAM350 Cable - Dimensions

8.6.1 Usage

The CBAM350.1-0 FETK interface cable is a 1 GBit/s cable adapter with a water tight socket. The cable shield is connected to socket. It is usable for ECUs with shielded housing.

8.6.2 Panel Cut-Out

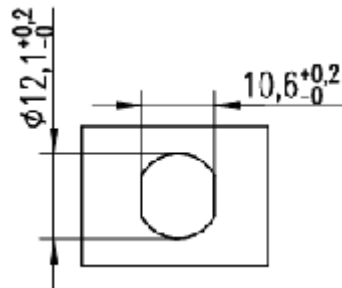
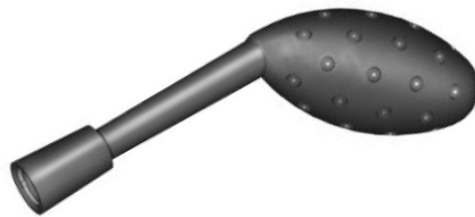

Fig. 8-8 Dimension Panel Cut-Out

8.6.3 Assembling



A Lemo tool, type "Lemo Spanner DCH.91.161.PA" is needed for assembling the connector (not included in the delivery).

NOTE

The Lemo Spanner DCH.91.161.PA is not included in the cable delivery, It need to be ordered separately. For detailed information on mounting accessories contact ETAS technical support.

8.6.4 Temperature Range

Condition	Temperature
Operating temperature	-40 °C to +125 °C

8.6.5 Ordering

Product	Length	Order Number
CBAM350.1-0m17	0.17 m	F 00K 111 439

8.7 CBAM305 Cable

8.7.1 Usage

The CBAM305.1 FETK cable is a 1 GBit/s Ethernet cable adapter with external power supply for FETKs.

Pre-assembled into PG9 screwing, shield connected to the screwing. It is usable for ECUs without permanent power supply inside. Depending on the version, there is a power plug on the ECU side or an open cable end on the power cable:

- For thin walled housings, use a through boring with 15.2 mm in the housing and mount the cable with a nut (not included) (SM-PE 9 Order number 52103210 from Lapp).
- For wall thickness more than 4mm cut a thread into the housing.

If the CBAM305.1-2m2 is used, a 2 pin Erni connector (214011 or compatible) must be available on the ECU as counterpart for the UBatt connector.

NOTE

It is recommended for safety reasons to connect the external permanent voltage and the switched voltage inside the ECU!

NOTE

For mounting the cable, cut a PG9 thread into the ECU housing. For thin walled housings use a nut SM-PE 9. It is available from Lapp (order number: 52103210).

8.7.2 Dimensions

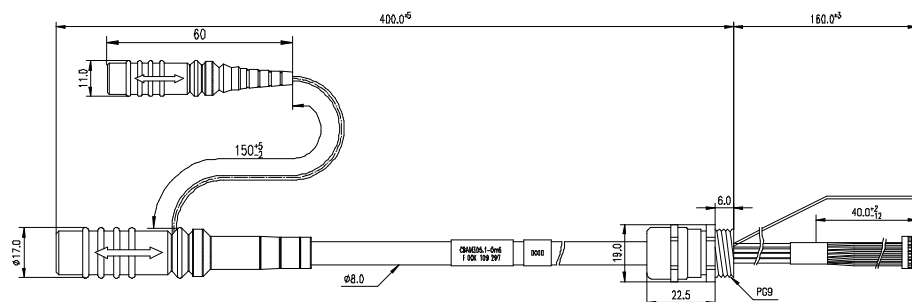

Fig. 8-9 CBAM305.1-0m6 Cable - Dimensions

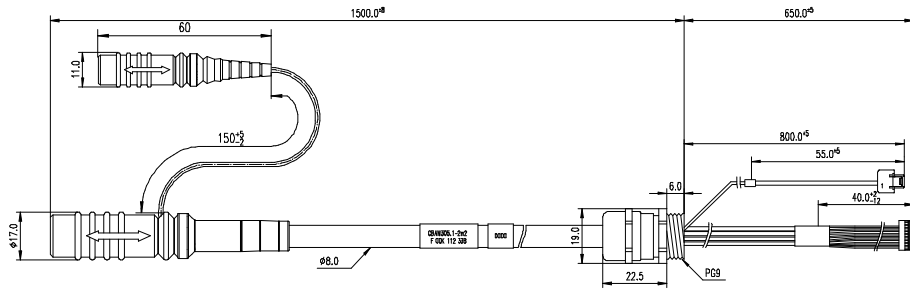

Fig. 8-10 CBAM305.1-2m2 Cable - Dimensions

8.7.3 Connectors

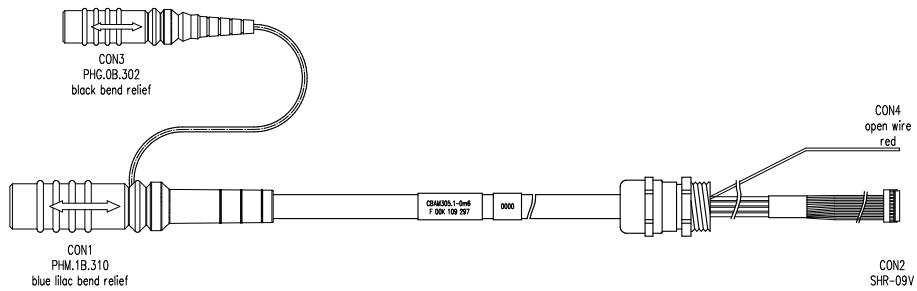
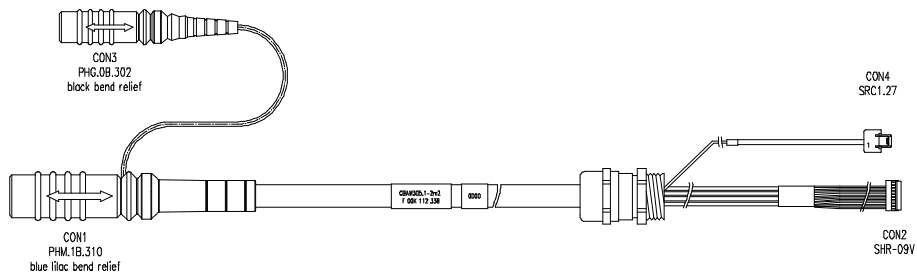

Fig. 8-11 CBAM305.1-0m6 - Connectors

Connector	Color	Target
CON1	Blue lila	Gbit Ethernet cable, e.g. CBE260
CON2	White	FETK
CON3	Black	Permanent power supply, K70.1 cable
CON4	Red	FETK UBATT



Connector	Color	Target
CON1	Blue lila	Gbit Ethernet cable, e.g. CBE260
CON2	White	FETK
CON3	Black	Permanent power supply, K70.1 cable
CON4	Red	2 pin ERNI power ECU connector

Fig. 8-12 CBAM305.1-2m2 - Connectors

8.7.4 Temperature Range

Condition	Temperature
Operating temperature	-40 °C to +125 °C

8.7.5 Tightness

Condition	IP Code
PG9 screwing	IP67

8.7.6 Ordering

Product	Length	Order Number
CBAM305.1-0m6	0.6 m	F 00K 109 297
CBAM305.1-2m2	2.2 m	F 00K 112 338

8.8 CBE260 Cable

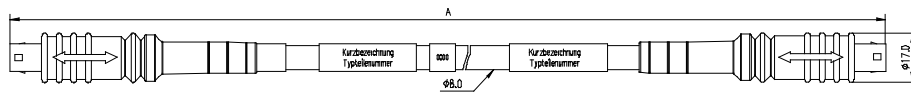

Fig. 8-13 CBE260 Cable

8.8.1 Usage

Gigabit Ethernet and Power Connection cable for FETK. Lemo connectors on both sides compliant to IP65. 3 m length.

The CBAE260 cable is a Gigabit Ethernet cable to connect an ETAS ES device with an FETK or another ES device. The cable supports power propagation.

8.8.2 Dimensions

Short Name	Length A
CBE260.1-3	300 cm
CBE260.1-5	500 cm
CBE260.1-8	800 cm

8.8.3 Connectors

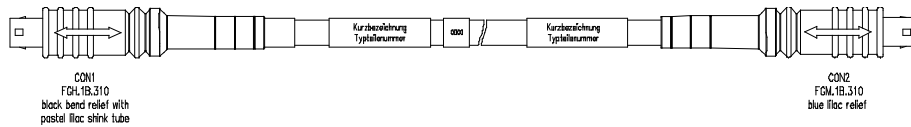

Fig. 8-14 CBE260 - Connectors

Connector	Color	Target
CON1	Pastel lila	ES8xx Downlink
CON2	Blue lila	ES8xx Uplink, FETK

8.8.4 Temperature Range

Condition	Temperature
Operating temperature	-40 °C to +120 °C

8.8.5 Ordering

Product	Length	Order Number
CBE260.1-3	3 m	F 00K 109 446
CBE260.1-5	5 m	F 00K 111 001
CBE260.1-8	8 m	F 00K 109 447

8.9 ETAM8 Adapter

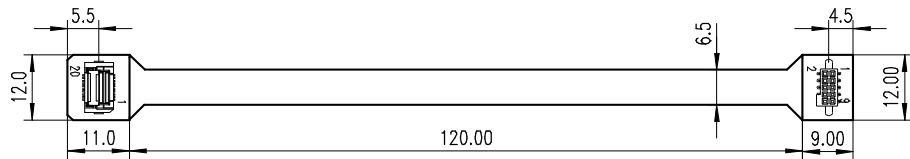

Fig. 8-15 ECU Adapter ETAM8 (bottom view)

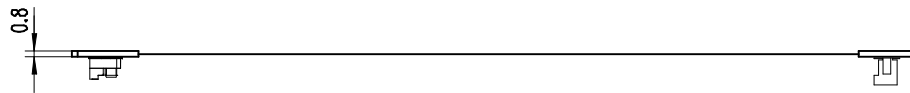

Fig. 8-16 ECU Adapter ETAM8 (side view)

8.9.1 Usage

The ETAM8 ECU adapter connects the ECU via a 10 pin SAMTEC TFM-105 connector to a BR_XETK-S, FETK-S or FETK-T.

There are two variants for the ETAM8 adapter available:

- ETAM8A hold the ECU in Reset, while the ETK is booting.
- ETAM8B do not pull the Reset low while booting.

With a ETAM8B adapter the FETK-S2.1 has the same reset behavior like FETK-T1.0.

 **NOTE**
See chapter "Installation" for details on mating connector to the ETAM8.

8.9.2 Pin Numbering

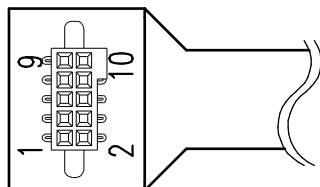

Fig. 8-17 ECU Adapter ETAM8 (pin numbering)

8.9.3 ECU Connector: Signal Modes

Pin Number	JTAG Mode	LFAST Mode	DAP Mode
1	GND	GND	GND
2	TCK	DRCLK	DAP0
3	/TRST	RXD-	/TRST
4	TDO	RXD+	DAP2
5	TMS	TXD+	DAP1
6	TDI	TXD-	-
7	WDGDIS	WDGDIS	WDGDIS
8	VDD (Sense)	VDD (Sense)	VDD (Sense)
9	/RESETOUT	/RESETOUT	/RESETOUT
10	/PORESET	/PORESET	/PORESET

8.9.4 Temperature Range

Condition	Temperature
Operating temperature	-40 °C to +110 °C

8.9.5 Ordering

Product	Length	Order Number
ETAM8A	0.11 m	F 00K 110 754
ETAM8B	0.11 m	F 00K 110 881

8.10 ETV5 Cable

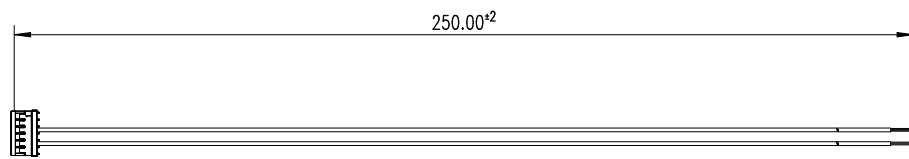

Fig. 8-18 Power Supply Cable ETV5

8.10.1 Usage

The ETV5 cable is an open wire power supply cable with one battery and GND connection.



NOTE

For better power integrity cut the cable to the shortest possible length.

8.10.2 Pin Assignment

Pin Number	Color	Signal	Description
1			Not connected
2			Not connected
3	Brown	GND	Power GND
4			Not connected
5	Red	SGUBATT1	Car Battery
6			Not connected

8.10.3 Temperature Range

Condition	Temperature
Operating temperature	-40 °C to +110 °C

8.10.4 Ordering

Product	Length	Order Number
ETV5	0.25 m	F 00K 111 701

8.11 ETAM2 Adapter

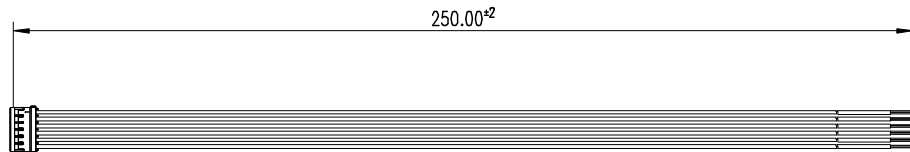

Fig. 8-19 FETK - ECU Adapter ETAM2

NOTE

See chapter "Installation" for details on mating connector to the ETAM2.

8.11.1 Pin Assignment



Fig. 8-20 ETAM2 Connector

8.11.2 ECU Signals

Pin	Color	Signal	Description
1	Blue	VDDPSTBY (Supply)	Permanent power to supply ECU interface (optional)
2	Yellow	VDDSTBY (Supply)	Permanent power to supply ECU ED-RAM
3	Brown	GND	Power ground
4	Green	CAL_Wakeup	Switch to Ubatt. ECU wake-up signal (for measurement preparation)
5	Red	SGUBATT2	Car battery
6	Red	SGUBATT1	Car battery

8.11.3 Ordering

Product	Length	Order Number
ETAM2	0.25 m	F 00K 109 306

8.12 ETAM5 Adapter

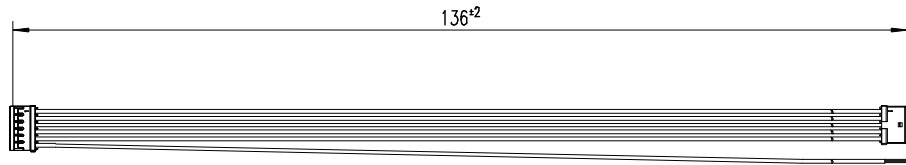

Fig. 8-21 FETK - ECU Adapter ETAM5

NOTE

See chapter "Installation" for details on mating connector to the ETAM5.

8.12.1 Pin Assignment

Molex Side A	Wire: Medi cable	5 mm stripped and tinned Side B	Molex Side C
Position	Color	Position	Position
1	Blue		1
2	Yellow		2
3	Brown		3
4	Green		4
5	Red		5
6	Red		

8.12.2 Ordering

Product	Length	Order Number
ETAM5	0.136 m	F 00K 110 101

8.13 ETAM9 Adapter

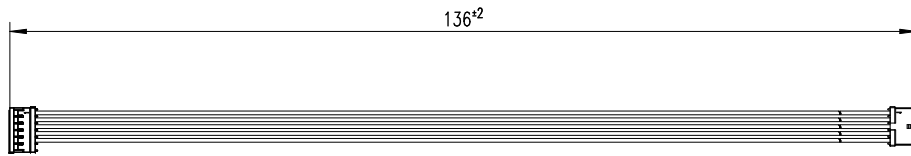

Fig. 8-22 FETK/ XETK - ECU Adapter ETAM9

8.13.1 Usage

The ETAM9 adapts the FETK/ XETK power signals (Molex 6 pin connector) to the ECU with an 5 pin Molex Pico Spox connector.

The ETAM9 cable requires on the ECU side an Vertical SMT Header connector [87437-0543] or an Right Angle SMT Header connector [87438-0543].

8.13.2 ECU Signals

Pin	Color	Signal	Description
1	Blue	VDDPSTBY (Supply)	Permanent power supply of ECU interface
2	Yellow	VDDSTBY (Supply)	Permanent power supply of ECU ED RAM
3	Brown	GND	Power ground
4	Green	Cal_Wakeup	Switch to Ubatt. ECU wake-up signal (for measurement preparation)
5	Red	SGUBATT1	Car battery
6	-	-	No Connect

8.13.3 Temperature Range

Condition	Temperature Range
Operating temperature	-40 °C to +110 °C

8.13.4 Order Information

Product	Length	Order Number
ETAM9 F/XETK-S ECU Adapter, MOLEX - MOLEX (6fc - 5fc), 0m136	0.136 m	F 00K-111-043

8.14 ETAM10 Adapter

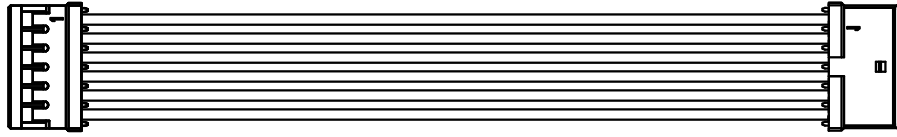

Fig. 8-23 FETK/ XETK - ECU Adapter ETAM10

MOLEX - MOLEX (6fc - 6fc) adapter cable for connecting an FETK or XETK to the ECU.

8.14.1 Usage

ETAM10 adapts the ETK power signals (Molex 6 pin connector) to an ECU with a 6 pin Molex PicoSpox connector.

The ECU connector is available as Vertical SMT Header [87437-0643] or Right Angle SMT Header [87438-0643].

8.14.2 Dimensions

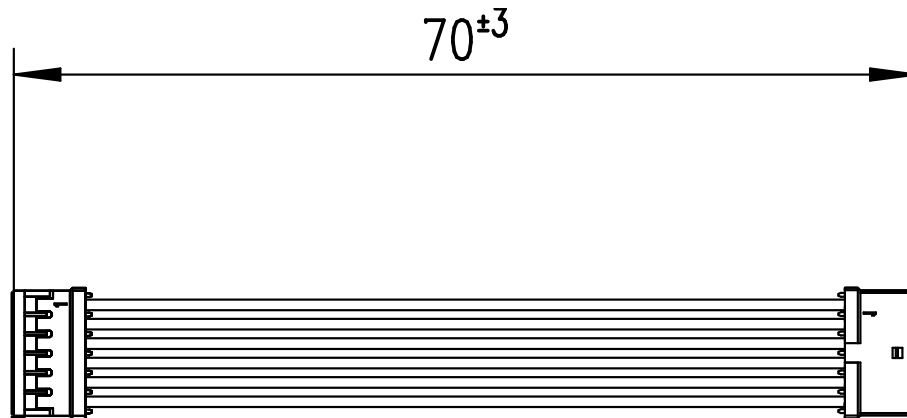

Fig. 8-24 ETAM10 Adapter Dimensions

8.14.3 ECU Signals

Pin	Color	Signal	Description
1	Blue	VDDPSTBY (Supply)	Permanent power supply of ECU interface
2	Yellow	VDDSTBY (Supply)	Permanent power supply of ECU ED RAM
3	Brown	Ground	Power ground
4	Green	Cal_Wakeup	Switch to Ubatt. ECU wake-up signal (for measurement preparation)
5	Red	SGUBATT2	Car battery
6	Red	SGUBATT1	Car battery

8.14.4 Temperature Range

Condition	Temperature Range
Operating temperature	-40 °C to +110 °C

8.14.5 Order Information

Product	Length	Order Number
ETAM10 F/XETK-S ECU Adapter, MOLEX - MOLEX (6fc - 6fc), 0m07	0.07 m	F 00K-111-814

9 Ordering Information

9.1 FETK-S2.1

Order Name	Short Name	Order Number
FETK-S2.1A Emulator probe for the Freescale / STM MPC57xx (Qorivva) MCU family	FETK-S2.1A	F 00K 111 102

Package Contents

- FETK-S2.1A Emulator probe for the Freescale / STM MPC57xx (Qorivva) MCU family
- List "Content of this Package"
- ETK Safety Advice
- China-RoHS-leaflet_Compact_cn

9.2 Cable

NOTE

We recommend to use ETAS cables or any other cables certified by the standards for the application. Adhere to the maximum permissible cable lengths!

Please contact your local ETAS representative for further cable information.

NOTE

The cables shown in chapter "Cables and Accessories" on page 50 are not included in the FETK-S2.1 delivery.

9.2.1 ECU Adapter Cable

NOTE

The hardware for mounting ECU adapter cable CBAM240.1 is not included in the cable delivery, they need to be ordered separately. For detailed information on mounting accessories contact ETAS technical support.

Order Name	Short Name	Order Number
FETK ECU Adapter Cable, pre-assembled into PG9 screwing, shield on ECU-Housing, Lemo 1B PHM - JST SHR (10fc-9fc), 0m60	CBAM300.3-0m6	F 00K 112 469
FETK ECU Adapter Cable, pre-assembled into GSC.1S screwing (M9x0,6), shield on ECU-Housing, Lemo 1B PHM - JST SHR (10mc-9fc), 0m60	CBAM320.1-0m6	F 00K 109 299
FETK ECU Adapter Cable, shield on ECU-Housing, Lemo 1B PHM - JST SHR (10fc-9fc), 0m60	CBAM340.1-0m6	F 00K 109 302
FETK adapter cable, 1 Gbit/s, shield is connected to ECU, Lemo 1B HMM - JST SHR (10mc-9fc), 0m17	CBAM350.1-0m17	F 00K 111 439

9.2.2 ECU Adapter and Power Supply Cable

Order Name	Short Name	Order Number
FETK ECU Adapter and Power Supply Cable, pre-assembled into PG9 screwing, shield on ECU-Housing, Lemo 1B PHM - JST SHR (10fc-9fc) / Lemo 0B PHG - open wire (2fc-1c), 0m60	CBAM305.1-0m6	F 00K 109 297
FETK ECU Adapter and Power Supply Cable, pre-assembled into PG9 screwing, shield on ECU-Housing, Lemo 1B PHM - JST SHR (10fc-9fc) / Lemo 0B PHG - open wire (2fc-1c), 2m2	CBAM305.1-2m2	F 00K 112 338

9.2.3 GBit Ethernet and Power Supply Cable

Order Name	Short Name	Order Number
GBit Ethernet and Power Connection Cable for FETK, Lemo 1B FGM - Lemo 1B FGH (10fc-10mc), 3 m	CBE260.1-3	F 00K 109 446
GBit Ethernet and Power Connection Cable for FETK, Lemo 1B FGM - Lemo 1B FGH (10fc-10mc), 5 m	CBE260.1-5	F 00K 111 001
GBit Ethernet and Power Connection Cable for FETK, Lemo 1B FGM - Lemo 1B FGH (10fc-10mc), 8 m	CBE260.1-8	F 00K 109 447

9.2.4 ECU Adapter

Order Name	Short Name	Order Number
ETAM8A BR_XETK-S3 ECU Adapter, FCI - SAMTEC SFM (20c - 10fc), 0m11	ETAM8A	F 00K 110 754
ETAM8B BR_XETK-S3 ECU Adapter, FCI - SAMTEC SFM (20c - 10fc), 0m11	ETAM8B	F 00K 110 881

9.2.5 Power Supply Cable

Order Name	Short Name	Order Number
ETV5 F/XETK-S ECU Adapter, MOLEX - open wires (6fc - 2c), 0m25	ETV5	F00K 111 701
ETAM2 XETK/FETK ECU Adapter, MOLEX - open wires (6fc - 6c), 0m25	ETAM2	F 00K 109 306
ETAM5 FETK ECU Adapter, MOLEX - MOLEX (6fc - 5fc+1c), 0m136	ETAM5	F 00K 110 101
ETAM9 F/XETK-S ECU Adapter, MOLEX - MOLEX (6fc - 5fc), 0m136	ETAM9	F00K 111 043
ETAM10 F/XETK-S ECU Adapter, MOLEX - MOLEX (6fc - 6fc), 0m07	ETAM10	F00K 111 814

9.3 Power Supply

For special applications ETAS can offer a isolated power supply unit. For detailed information contact ETAS technical support.

10 Contact Information

ETAS Headquarters

ETAS GmbH

Borsigstraße 24
70469 Stuttgart
Germany

Phone: +49 711 3423-0
Fax: +49 711 3423-2106
Internet: www.etas.com

ETAS Subsidiaries and Technical Support

For details of your local sales office as well as your local technical support team and product hotlines, take a look at the ETAS website:

ETAS subsidiaries Internet: www.etas.com/en/contact.php
ETAS technical support Internet: www.etas.com/en/hotlines.php

Figures

Fig. 2-1	Adhesive Label (Example: Label for XETK-S14.0)	13
Fig. 2-2	WEEE-Symbol	14
Fig. 3-1	FETK-S2.1	16
Fig. 4-1	FETK-S2.1 Architecture	19
Fig. 4-2	Location of the ECU Interfaces	20
Fig. 4-3	ETAM8 Adapter mounted at CON1	21
Fig. 4-4	Location of the FETK Ethernet Interface connector (CON3)	21
Fig. 4-5	Location of the FETK-S2.1 Power Supply Connectors	22
Fig. 4-6	Equivalent Circuitry of the ECU JTAG/ LFAST Interface (ECU)	24
Fig. 5-1	FETK-S2.1 Threads and Heat Spreader	28
Fig. 5-2	Attaching the FETK-S2.1 to the ECU	29
Fig. 5-3	FETK-S2.1 Connection to the ECU	30
Fig. 5-4	FETK-S2.1 Connection to the ECU	30
Fig. 5-5	Wiring - FETK Ethernet Interface	31
Fig. 5-6	FETK-S2.1 Power Supply wiring with CBAM300.3 Cable	31
Fig. 5-7	FETK-S2.1 Power Supply wiring with CBAM320.1 Cable	32
Fig. 5-8	FETK-S2.1 Power Supply wiring with CBAM350.1 Cable	32
Fig. 5-9	FETK-S2.1 Power Supply wiring with CBAM305.1 Cable	33
Fig. 5-10	Isolated Power Supply inside ECU	33
Fig. 7-1	Location of the FETK-S2.1 Interfaces	44
Fig. 7-2	ECU Interface Connector CON1	44
Fig. 7-3	Power Supply Connector CON2	47
Fig. 7-4	FETK Ethernet Interface Connector CON3	47
Fig. 7-5	FETK-S2.1 Dimensions - Top View	48
Fig. 7-6	FETK-S2.1 Dimensions - Side View	49
Fig. 8-1	CBAM300.3 Cable - Dimensions	51
Fig. 8-2	CBAM300.3 Cable - Connectors	51
Fig. 8-3	CBAM320 Cable - Dimensions	52
Fig. 8-4	CBAM320 Cable - Connectors	52
Fig. 8-5	CBAM340 Cable - Dimensions	53
Fig. 8-6	CBAM340 Cable - Connectors	53
Fig. 8-7	CBAM350 Cable - Dimensions	54
Fig. 8-8	Dimension Panel Cut-Out	54
Fig. 8-9	CBAM305.1-0m6 Cable - Dimensions	56
Fig. 8-10	CBAM305.1-2m2 Cable - Dimensions	57
Fig. 8-11	CBAM305.1-0m6 - Connectors	57

Fig. 8-12	CBAM305.1-2m2 - Connectors	57
Fig. 8-13	CBE260 Cable	59
Fig. 8-14	CBE260 - Connectors	59
Fig. 8-15	ECU Adapter ETAM8 (bottom view)	60
Fig. 8-16	ECU Adapter ETAM8 (side view)	60
Fig. 8-17	ECU Adapter ETAM8 (pin numbering)	60
Fig. 8-18	Power Supply Cable ETV5	62
Fig. 8-19	FETK - ECU Adapter ETAM2	63
Fig. 8-20	ETAM2 Connector	63
Fig. 8-21	FETK - ECU Adapter ETAM5	64
Fig. 8-22	FETK/ XETK - ECU Adapter ETAM9	65
Fig. 8-23	FETK/ XETK - ECU Adapter ETAM10	66
Fig. 8-24	ETAM10 Adapter Dimensions	66

Index

A		
Accident prevention	9
Adapter		
ETAM10	66
ETAM2	63
ETAM8	60
ETAM9	65
Applications	16
Architecture	19
B		
Blockdiagram	19
C		
Cable		
CBAM300	51
CBAM305	56
CBAM320	52
CBAM340	53
CBAM350	54
CBE260	59
Configuration Parameter	35
D		
Data Emulation Memory	37
Data Measurement	23
Documentation	9
E		
ECU		
Interface	20
Interface Characteristics	41
Voltage Supervisor	22
ECU Interface Characteristics	41
Electrical Characteristics	41
Environmental Conditions	38
Ethernet Interface	21
ETK / XETK / FETK Configuration	34
F		
Features	17
H		
Hardware Description	19
I		
Identifications on the product	13
Interface		
ECU	20
Introduction	16
Isolated Power Supply	33
J		
JTAG and LFAST Interface	24
M		
Measurement Data Memory	38
Mechanical Dimension	48
Mounting to the ECU Housing		
Mounting Material	27
Mounting Steps	28
O		
Ordering Information	68
P		
PC network adapter	36
Pin Assignment	44
Power Supply	22, 31, 70
Cables, combined	70
Connector	22
Product		
Exclusion of liability	9
Product Back	14
Q		
Qualification, required	9
R		
REACH regulation (EU)	15
Recycling	14
Reset	26
RoHS conformity		
China	15
European Union	14
S		
Safety at work	9
Safety precautions	9
Software Support	37
System Requirements	36
T		
Test Characteristics	39
U		
UKCA conformity	14
Use, intended	9
V		
Voltage Supervisor	22
W		
Waste Electrical and Electronic Equipment	14
WEEE	14
WEEE take-back system	14