Two red lines intersect on a blue background. One line starts from the top right and goes down-left. The other starts from the top left and goes down-right. They meet at a point in the upper middle of the page. There are small white circles at the intersection and at the end of the line starting from the top left.

# ETAS ETK-T2.2 Emulator Probe for Infineon TC1792, TC1793(ED), TC1796(ED) and TC1797(ED)

## User Guide

## Copyright

---

The data in this document may not be altered or amended without special notification from ETAS GmbH. ETAS GmbH undertakes no further obligation in relation to this document. The software described in it can only be used if the customer is in possession of a general license agreement or single license. Using and copying is only allowed in concurrence with the specifications stipulated in the contract.

Under no circumstances may any part of this document be copied, reproduced, transmitted, stored in a retrieval system or translated into another language without the express written permission of ETAS GmbH.

© **Copyright 2021** ETAS GmbH, Stuttgart

The names and designations used in this document are trademarks or brands belonging to the respective owners.

ETK-T2.2 User Guide R05 EN - 07.2021

# Contents

---

<b>1</b>	<b>About this Document</b> .....	<b>6</b>
1.1	Classification of Safety Messages .....	6
1.2	Presentation of Instructions .....	6
1.3	Typographical Conventions .....	7
1.4	Presentation of Supporting Information .....	7
<b>2</b>	<b>Basic Safety Notices</b> .....	<b>8</b>
2.1	General Safety Information .....	8
2.2	Requirements for Users and Duties for Operators .....	8
2.3	Intended Use .....	8
2.4	Identifications on the Product .....	11
2.5	Taking the Product Back and Recycling .....	12
2.6	CE conformity .....	12
2.7	UKCA conformity .....	12
2.8	RoHS Conformity .....	13
2.9	Declarable Substances .....	13
2.10	Use of Open Source Software .....	13
<b>3</b>	<b>Introduction</b> .....	<b>14</b>
3.1	Applications .....	14
3.2	Features .....	15
<b>4</b>	<b>Hardware Description</b> .....	<b>16</b>
4.1	ETK-T2.2 Versions .....	16
4.2	Architecture .....	16
4.3	BGA Connector .....	17
4.4	Microcontroller Interface .....	17
4.5	Data Emulation and Data Measurement .....	19
4.5.1	Data Emulation Memory .....	19
4.5.2	Measurement Data Memory .....	19
4.5.3	Triggering of Measurement Data Capture .....	20
4.5.4	Data Retention in Data Emulation Memory .....	21
4.6	Data Flash Memory .....	21
4.7	Code Flash Memory .....	21
4.8	Braindead Flashing (ETK-T2.2B and ETK-T2.2C) .....	21
4.9	ETK-T2.2 Deactivation .....	22
4.10	Reset .....	22
4.11	Power Supply .....	23
4.12	Serial ETK Interface .....	24
4.13	Debug Interface .....	25

4.14	Status LEDs.....	26
4.15	Chip Select Configuration Bridge .....	27
<b>5</b>	<b>Installation .....</b>	<b>28</b>
5.1	Connection to the ECU .....	28
5.2	Connection to the Debugger .....	29
5.3	Connecting to the Power Supply.....	30
5.3.1	Permanent Power Supply inside ECU available .....	30
5.3.2	Permanent Power Supply inside ECU not available.....	30
5.3.3	Isolated Power Supply inside ECU .....	30
<b>6</b>	<b>ETK Configuration .....</b>	<b>31</b>
6.1	Overview .....	31
6.2	ETK Configuration Tool .....	31
6.3	Configuration Parameter .....	32
<b>7</b>	<b>Technical Data .....</b>	<b>34</b>
7.1	ETK-T2.2 Versions.....	34
7.2	System Requirements.....	34
7.2.1	ETAS Hardware .....	34
7.2.2	Software and supported Microcontrollers.....	34
7.3	Environmental Conditions .....	35
7.4	Power Supply .....	35
7.5	Memory and Configuration .....	35
7.6	Serial ETK Interface .....	35
7.7	Microcontroller Bus Interface .....	36
7.8	Testcharacteristics .....	36
7.9	Electrical Characteristics .....	37
7.9.1	With Braindead Flashing (ETK-T2.2B and ETK-T2.2C) .....	37
7.9.2	Without Braindead Flashing (ETK-T2.2A) .....	39
7.10	Switching Characteristics .....	40
7.10.1	Read Timing: Data Emulation and Measurement Data DPR .....	40
7.10.2	Write Timing: Data Emulation and Measurement Data DPR .....	40
7.11	Power Supply Connector CON2 .....	41
7.12	Mechanical Dimensions.....	41
7.12.1	ETK-T2.2A and ETK-T2.2B .....	41
7.12.2	ETK-T2.2C .....	43
7.12.3	ETK-T2.2D .....	44
<b>8</b>	<b>Cables and Accessories .....</b>	<b>45</b>
8.1	Interface Cables.....	45
8.1.1	Cable KA54 (with PG Cable Gland) .....	45
8.2	Cable KA55 .....	47
8.2.1	Cable CBAM200 .....	47
8.3	Power Supply Cables .....	47
8.3.1	Cable ETV .....	47
8.3.2	Cable with Filtercoil ETV2.....	48

8.3.3	Cable K70 .....	48
8.3.4	Cable KA50 .....	48
8.3.5	Cable CBM200 .....	48
8.4	Combined Interface and Power Supply Cables .....	49
8.4.1	Cable CBAM210 .....	49
8.4.2	Cable CBAM220 .....	49
8.5	Adapters .....	50
8.5.1	Debug Adapter ETAF5 .....	50
8.5.2	Debug Adapter ETAF9 .....	51
<b>9</b>	<b>Ordering Information .....</b>	<b>52</b>
9.1	ETK-T2.2 .....	52
9.1.1	ETK-T2.2A .....	52
9.1.2	ETK-T2.2B .....	52
9.1.3	ETK-T2.2C .....	52
9.1.4	ETK-T2.2D .....	53
9.2	ECU/ETK Sockets and Adapters .....	53
9.2.1	Socket ECU - ETK .....	53
9.2.2	BGA Adapter ETK - Microcontroller .....	53
9.3	Debug Adapter .....	53
9.4	Cables .....	53
9.4.1	Power Supply Cables .....	54
9.4.2	Combined Interface and Power Supply Cables .....	54
9.4.3	Interface Cables .....	54
9.5	Power Supply .....	55
<b>10</b>	<b>Contact Information .....</b>	<b>56</b>
	<b>Figures .....</b>	<b>57</b>
	<b>Index .....</b>	<b>59</b>

# 1 About this Document

---

## 1.1 Classification of Safety Messages

---

The safety messages used here warn of dangers that can lead to personal injury or damage to property:



### **DANGER**

---

indicates a hazardous situation with a high risk of death or serious injury if not avoided.



### **WARNING**

---

indicates a hazardous situation of medium risk, which could result in death or serious injury if not avoided.



### **CAUTION**

---

indicates a hazardous situation of low risk, which may result in minor or moderate injury if not avoided.

### **NOTICE**

---

indicates a situation, which may result in damage to property if not avoided.

## 1.2 Presentation of Instructions

---

The target to be achieved is defined in the heading. The necessary steps for his are in a step-by-step guide:

### Target definition

1. Step 1
2. Step 2
3. Step 3
- > Result

## 1.3 Typographical Conventions

### Hardware

<b>Bold</b>	Menu commands, buttons, labels of the product
<i>Italic</i>	Emphasis on content and newly introduced terms

## 1.4 Presentation of Supporting Information



### **NOTE**

Contains additional supporting information.

## 2 Basic Safety Notices

---

This chapter contains information about the following topics:

- General Safety Information . . . . . 8
- Requirements for Users and Duties for Operators . . . . . 8
- Intended Use . . . . . 8
- Identifications on the Product. . . . . 11
- Taking the Product Back and Recycling . . . . . 12
- CE conformity . . . . . 12
- UKCA conformity. . . . . 12
- RoHS Conformity . . . . . 13
- Declarable Substances. . . . . 13
- Use of Open Source Software. . . . . 13

### 2.1 General Safety Information

---

Please observe the Product Safety Notices ("ETAS Safety Notice") and the following safety notices to avoid health issues or damage to the device.



#### NOTE

---

Carefully read the documentation (Product Safety Advice and this User Guide) that belongs to the product prior to the startup.

ETAS GmbH does not assume any liability for damages resulting from improper handling, unintended use or non-observance of the safety precautions.

### 2.2 Requirements for Users and Duties for Operators

---

The product may be assembled, operated and maintained only if you have the necessary qualification and experience for this product. Incorrect operation or operation by users without sufficient qualification may lead to injuries or death or property damages.

#### General Safety at Work

The existing regulations for safety at work and accident prevention must be followed. All applicable regulations and statutes regarding operation must be strictly followed when using this product.

### 2.3 Intended Use

---

An ETK is an electronic component that is installed in a vehicle control unit (ECU) to read data from the ECU or write data to the ECU.

#### Application Area of the Product

This product was developed and approved for automotive applications. For use in other application areas, please contact your ETAS contact partner.



## Requirements for Operation

The following requirements are necessary for safe operation of the product:

- Use the product only according to the specifications in the corresponding User Guide. With any deviating operation, the product safety is no longer ensured.
- Observe the regulations applicable at the operating location concerning electrical safety as well as the laws and regulations concerning work safety!
- Do not apply any voltages to the connections of the product that do not correspond to the specifications of the respective connection.
- Connect only current circuits with safety extra-low voltage in accordance with EN 61140 (degree of protection III) to the connections of the product.
- The power supply for the product must be safely disconnected from the supply voltage. For example, use a car battery or a suitable lab power supply.
- Use only lab power supplies with double protection to the supply system.
- Ensure that the connections of the power supply are easily accessible.
- The module does not have an operating voltage switch.
  - Switch on the product by connecting the power supply cable with the power supply or by switching on the power supply.
  - Switch off the product by disconnecting it from the power supply or by switching off the power supply.



### **DANGER**

**Connect the power cord only with a vehicle battery or with a lab power supply! A connection to power outlets is prohibited.**

- Route the power cord in such a way that it is protected against abrasion, damages, deformation and kinking. Do not place any objects on the power cord.
- Never apply force to insert a plug into a socket. Ensure that there is no contamination in and on the connection, that the plug fits the socket, and that you correctly aligned the plugs with the connection.
- Do not use the product in a wet or damp environment.
- Do not use the product in potentially explosive atmospheres.
- Keep the surfaces of the product clean and dry.

## Potential Equalization



### **CAUTION**

**Danger from inadvertent current flow!**

Depending on the design, the shield of the Ethernet cables can be connected with the housing of the module. Install the products only on components with the same electrical potential or isolate the products from the components.

## Requirements for the technical State of the Product

The product is designed in accordance with state-of-the-art technology and recognized safety rules. The product may be operated only in a technically flawless condition and according to the intended purpose and with regard to safety and dangers as stated in the respective product documentation. If the product is not used according to its intended purpose, the protection of the product may be impaired.

## Maintenance and Cleaning

The product is maintenance-free. Use a lightly moistened, soft, lint-free cloth for cleaning the product. Ensure that no moisture can enter. Never spray cleaning agents directly onto the product. Do not use any sprays, solvents or abrasive cleaners which could damage the product.

## Transport and Installation



### CAUTION

#### **The ETK can be damaged or destroyed!**

Some components of the ETK board may be damaged or destroyed by electrostatic discharges. Please keep the ETK in its storage package until it is installed.

The board should only be taken from its package, configured, and installed at a work place that is protected against static discharge.



### CAUTION

During installation and removal, ECU and ETK must be in a de-energized state!



### CAUTION

#### **Risk of short circuiting the internal signals of the ETK!**

When you mount the ETK to the ECU, you must ensure that the screws and washers used will not penetrate the ETK printed circuit board.



### CAUTION

#### **Differences in case ground potentials can cause high currents to flow through the shields of the cables that connect various system modules.**

Ensure that the module mounting surfaces are at the same electrical potential or insulate the modules from their mounting surfaces.

### Cabling

Use exclusively ETAS cables at the connections of the product! Adhere to the maximum permissible cable lengths! Observe the assignment of the cables to the connectors! Detailed information about cabling is located in the ETK User Guides.

## 2.4 Identifications on the Product



Fig. 2-1 Adhesive Label (Example: Label for XETK-S14.0)

The following symbols are used for identifications of the product:

Symbol	Description
	The User Guide must be read prior to the startup of the product!
	Symbol for WEEE, see chapter 2.5 on page 12
	Marking for CE conformity, see chapter 2.6 on page 12)
	Marking for UKCA conformity, see chapter 2.7 on page 12)
	Symbol for China RoHS, see chapter on page 13
	Symbol for China RoHS, see chapter on page 13
	Symbol for electrostatic sensitive components
XETK-S14.0A	Product designation (example)
F 00K 110 722	Order number of the product (example)
SN: yyxxxxx	Serial number (7-digit)
XXXX/YY	Product version
ZZZZ	Year of manufacture
ETAS GmbH, PO Box 300220, 70442 Stuttgart, Germany	Manufacturer's address

**NOTE**

For symbols and product information one or several adhesive labels can be used.

## 2.5 Taking the Product Back and Recycling

---

The European Union has passed a directive called Waste Electrical and Electronic Equipment, or WEEE for short, to ensure that systems are setup throughout the EU for the collection, treating and recycling of electronic waste.

This ensures that the devices are recycled in a resource-saving way representing no danger to health or the environment.



**Fig. 2-2** WEEE-Symbol

The WEEE symbol (see Fig. 2-2 on page 12) on the product or its packaging shows that the product must not be disposed of as residual garbage.

The user is obliged to collect the old devices separately and return them to the WEEE take-back system for recycling. The WEEE directive concerns all ETAS devices but not external cables or batteries.

For more information on the ETAS GmbH Recycling software, contact the ETAS sales and service locations.

## 2.6 CE conformity

---

With the CE mark attached to the product or its packaging, ETAS confirms that the product corresponds to the product-specific, applicable directives of the European Union.

The CE Declaration of Conformity for the product is available upon request.

## 2.7 UKCA conformity

---

With the UKCA mark attached to the product or its packaging, ETAS confirms that the product corresponds to the product-specific, applicable standards and directives of Great Britain.

The UKCA declaration of conformity for the product is available on request.

## 2.8 **RoHS Conformity**

---

### **European Union**

The EU Directive 2011/65/EU limits the use of certain dangerous materials for electrical and electronic devices (RoHS conformity).

This product does not contain any of the restricted substances specified in the EU Directive 2011/65/EU or exceeds the maximum concentrations stipulated therein. For individual electronic components used in our products, there are currently no equivalent alternative substances, which is why we make use of the exception 7C-I in Annex III of this Directive.

ETAS confirms that the product corresponds to this directive which is applicable in the European Union.

### **China**

ETAS confirms that the product meets the product-specific applicable guidelines of the China RoHS (Management Methods for Controlling Pollution Caused by Electronic Information Products Regulation) applicable in China with the China RoHS marking affixed to the product or its packaging.

## 2.9 **Declarable Substances**

---

### **European Union**

Some products from ETAS GmbH (e.g. modules, boards, cables) use components with substances that are subject to declaration in accordance with the REACH regulation (EU) no.1907/2006.

Detailed information is located in the ETAS download center in the customer information "REACH Declaration" ([www.etas.com/Reach](http://www.etas.com/Reach)). This information is continuously being updated.

## 2.10 **Use of Open Source Software**

---

The product uses Open Source Software (OSS). This software is installed in the product at the time of delivery and does not have to be installed or updated by the user. Reference shall be made to the use of the software in order to fulfill OSS licensing terms. Additional information is available in the document "OSS Attributions List" at the ETAS website [www.etas.com](http://www.etas.com).

### 3 Introduction

This chapter contains information about the following topics:

- Applications ..... 14
- Features ..... 15

#### 3.1 Applications

The ETK-T2.2 is an emulator probe especially for the Infineon AUDD-NG TC1792/TC1793/TC1796/TC1797 "series microcontroller" and TC1793ED/TC1796ED/TC1797ED "emulation devices".

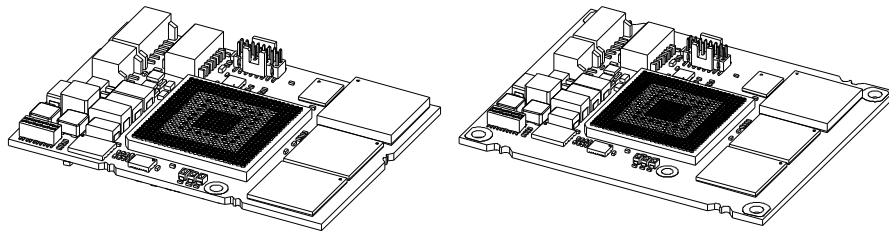

**Fig. 3-1** ETK-T2.2A/ ETK-T2.2B (left) and ETK-T2.2C (right)

It is compatible with the ETAS calibration and development system interface (e.g. ES590, ES591, ES592, ES910 and ES1000.2/ES1000.3 with ES1232-A).

The ETK-T2.2 can be ordered in different functional and mechanical versions:

ETK-T2.2 Version	Braided Flash Support	PCB with Mounting Holes	Directly soldered Microcontroller
ETK-T2.2A	No	No	No
ETK-T2.2B	Yes	No	No
ETK-T2.2C	Yes	Yes	No
ETK-T2.2D	No	No	Yes <sup>1)</sup>

<sup>1)</sup>: Microcontroller provided by customer

## 3.2 Features

---

- Applicable for AUDDO-NG TriCore with external 32-bit bus
- Supports 32-, 16- and 8-bit access to the data emulation memory
- CPU bus interface voltage 2.5 V compatible (3.3 V tolerant)
- Two pages of data emulation/measurement data memory available, each with 1024 kByte
- Permanent storage of emulation data in flash memory
- Supports "Braindead Flash" function  
(only version ETK-T2.2B and ETK-T2.2C, refer to chapter 4.8 on page 21 and to chapter 9.1 on page 52)
- Provides a JTAG connector to adapt a debugger
- Serial interface with 100 MBit/s to the calibration and development system
- ETK chip select configuration bridge
- Permanent storage of configuration in EEPROM
- ECU flashing via ETK
- Firmware update (programming of the logic device) through software; removal of ETK or ECU not necessary.

For more technical data on the ETK-T2.2 consult the chapter "Technical Data" on page 34.

## 4 Hardware Description

This chapter contains information about the following topics:

• ETK-T2.2 Versions .....	16
• Architecture .....	17
• BGA Connector .....	17
• Microcontroller Interface .....	18
• Data Emulation and Data Measurement .....	20
• Data Flash Memory .....	22
• Code Flash Memory .....	22
• Braintead Flashing (ETK-T2.2B and ETK-T2.2C) .....	22
• ETK-T2.2 Deactivation .....	23
• Reset .....	23
• Power Supply .....	24
• Serial ETK Interface .....	25
• Debug Interface .....	26
• Status LEDs .....	27
• Chip Select Configuration Bridge .....	28

### 4.1 ETK-T2.2 Versions

The ETK-T2.2 can be ordered in different functional and mechanical versions:

ETK-T2.2 Version	Braintead Flash Support	PCB with Mounting Holes	Directly soldered Microcontroller
ETK-T2.2A	No	No	No
ETK-T2.2B	Yes	No	No
ETK-T2.2C	Yes	Yes	No
ETK-T2.2D	No	No	Yes <sup>1)</sup>

<sup>1)</sup>: Microcontroller provided by customer





## 4.4 Microcontroller Interface

The whole microcontroller interface to the calibration and development system memories has a 32 bit wide data bus and uses only one chip select for read and write accesses.

The microcontroller can read and write its data directly from or to the data emulation and measurement data memory. Fig. 4-2 on page 18 and Fig. 4-3 on page 18 show an overview of the system with "on chip" Flash and RAM and external Flash and RAM memory. It also show the possibilities to access the different memories with its chip selects. The chip select of the data emulation and measurement data memory can be chosen (/CS1, /CS2, /CS3 or /CSCOMB) by soldering the respective bridge on the PCB (see 4.15 "Chip Select Configuration Bridge").

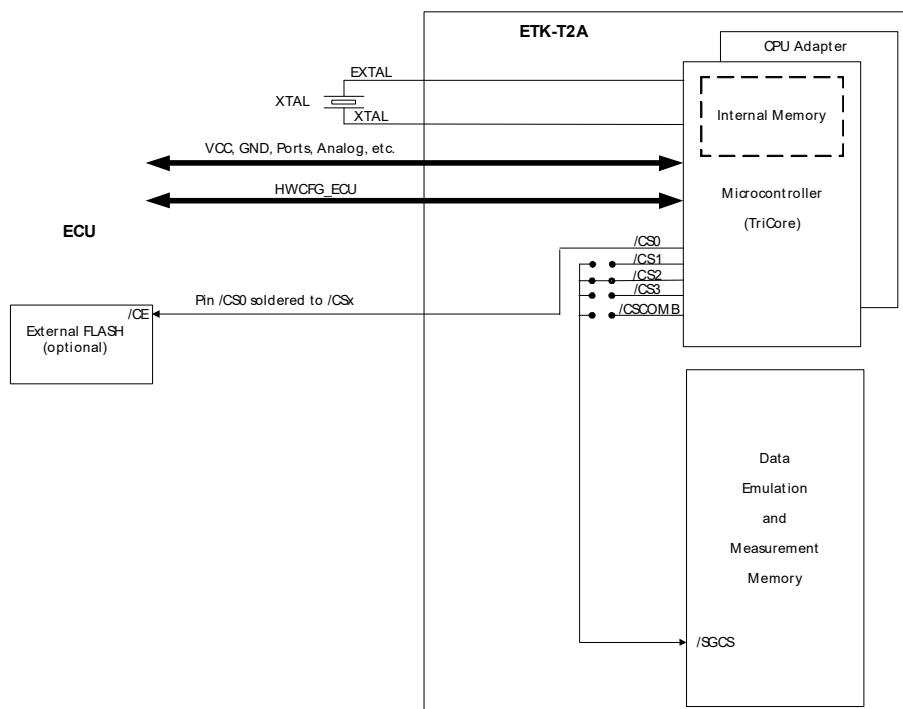

**Fig. 4-2** ETK-T2.2A, ETK-T2.2D: internal and external Memory

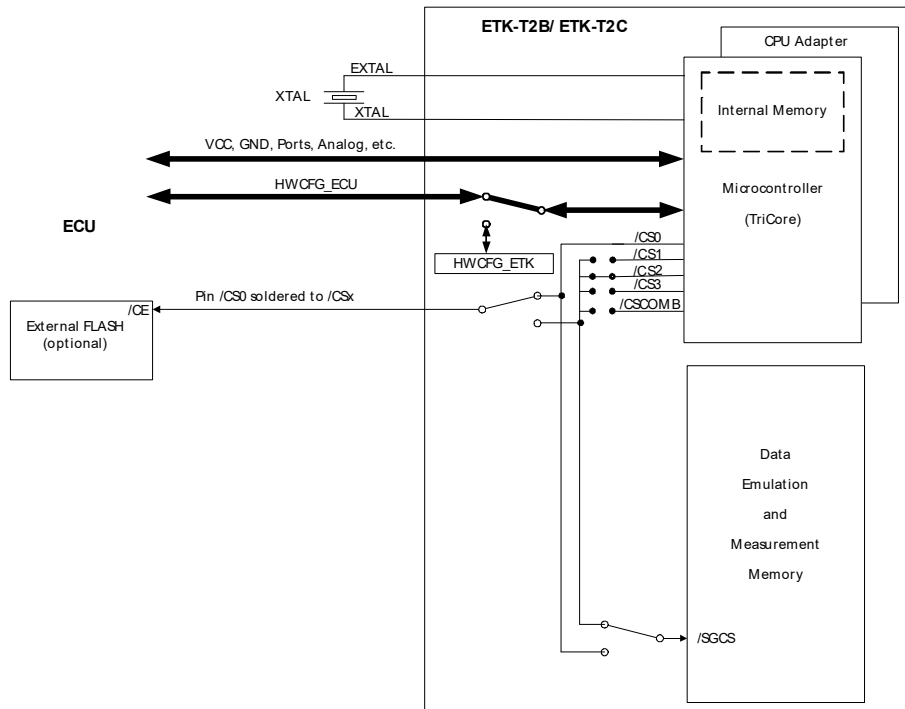

**Fig. 4-3** ETK-T2.2B, ETK-T2.2C: internal and external Memory

## 4.5 Data Emulation and Data Measurement

The complete data emulation and measurement data memory consists of two 1024 kByte pages (Fig. 4-4 "Data Emulation and Measurement Data Memory: 2 Pages with 1024 kByte each"). The address range of the used chip select to address the data emulation and measurement memory must be 1024 kByte and it must be defined at a 1024 kByte boundary.

Data emulation memory and measurement data memory must be located inside this 1024 kByte address range. The segmentation of this address range between both memory parts is variable. The measurement data memory and data emulation memory can have variable size and offset addresses inside this fixed address range.

### 4.5.1 Data Emulation Memory

During operation of the ECU, only program data, not program code, can be modified by using the data emulation memory. Modification of program code would inevitably lead to a system crash. The program code is continuously processed out of the internal or external memory.

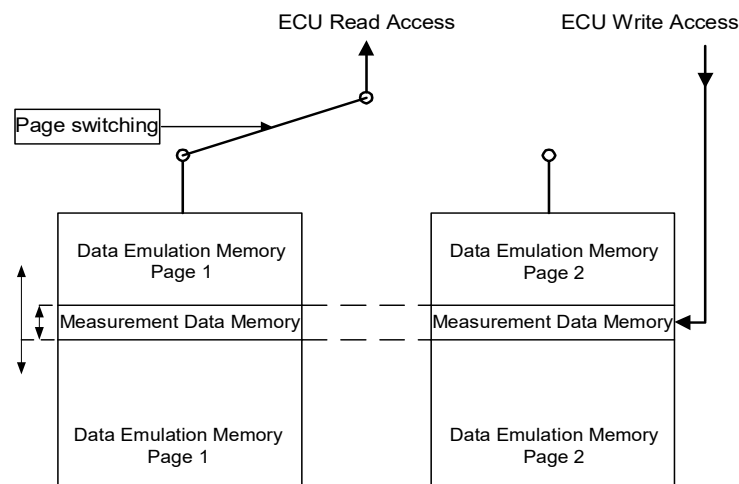

**Fig. 4-4** Data Emulation and Measurement Data Memory: 2 Pages with 1024 kByte each

Reference data can be stored on one page ("Reference page") while the data on the other page ("Working page") can be modified. It is possible to switch between the two pages during operation through the application software.

### 4.5.2 Measurement Data Memory

The measurement data memory must be located within the address space of the data emulation and measurement data memory. It can have variable size.

The measured data stored here can be transferred to the calibration and development system via the serial ETK interface.

#### NOTE

Because there is no write protection of the data emulation memory possible, care must be taken not to override emulation data.

### 4.5.3 Triggering of Measurement Data Capture

The exact procedure for capturing measured data is explained in the documentation Display Tables 12 and 13; only the hardware-specific features are mentioned here. The ECU microcontroller initiates a data acquisition task by writing an arbitrary value to the trigger address at the so called trigger segment. The software of the ECU is able to start different data acquisition tasks by writing different trigger addresses (trigger 0 to trigger 31).

The ETK-T2.2 contains a trigger comparator which selects a segment of 256 Byte out of the measurement data memory address space (at a 256 Byte limit). This limit is known as the trigger segment address. Fig. 4-5 "Division of the 256 Byte Trigger Segment" shows the configuration of the 256 Byte trigger segment.

The ETK-T2.2 supports up to 32 direct hardware triggers by providing 32 trigger addresses within the trigger segment.

 **NOTE**

The unused address areas within the trigger segment are reserved for future applications and must not be used for other purposes.

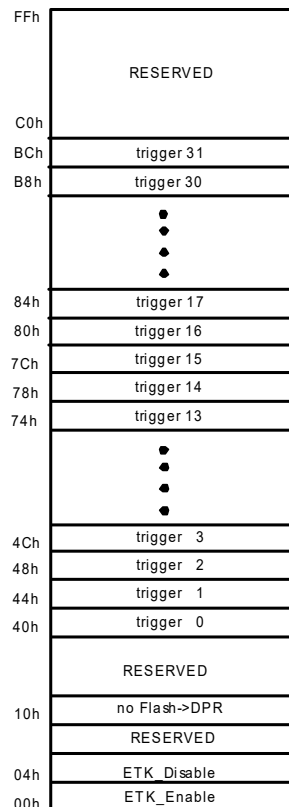

**Fig. 4-5** Division of the 256 Byte Trigger Segment

#### 4.5.4 Data Retention in Data Emulation Memory

The data emulation and measurement data memory physically consists of a static Dual Port RAM and is permanently supplied with power from the car battery, to guarantee that data is preserved even when the ignition is switched off. If the ECU with ETK is isolated from the battery, all data will be lost. For brief power interruptions, e.g. during a cold start procedure, buffering is guaranteed through capacitors for several milliseconds.

#### 4.6 Data Flash Memory

---

Flash memory is provided on the ETK-T2.2 for permanent storage of emulation data. Users can copy the contents of the data emulation and measurement data memory into the flash memory using the operating software. It is recommended that an updated data set is always stored in the flash memory.

The ETK-T2.2 has a circuit which recognizes and stores power failures. If this circuit detects a longer power failure, and therefore a possible inconsistency of the emulation data, the ETK controller initiates a copying procedure Flash memory to DPR upon restart. The Flash memory data is copied to both emulation pages. A green LED on the ETK displays the procedure. The operating software announces the procedure by a message in the status line.

 **NOTE**

The Flash memory on the ETK-T2.2 only stores data which exists in the data emulation and measurement data memory of the ETK-T2.2. The program code is stored only in the ECU Flash memory.

#### 4.7 Code Flash Memory

---

The program code is not emulated by the ETK-T2.2. The program code is stored in the ECU Flash memory ("on chip" and/or external) and is not modified by the ETK-T2.2. Only the accessible emulation data areas are emulated by the ETK-T2.2. The ECU Flash memory can be programmed with the normal Flash memory programming tools.

#### 4.8 Braintead Flashing (ETK-T2.2B and ETK-T2.2C)

---

 **NOTE**

Only ETK-T2.2 versions ETK-T2.2B and ETK-T2.2C support the "Braintead Flash" function (refer to chapter 9.1 on page 52).

In order to support braintead flashing the ETK-T2.2B/ ETK-T2.2C provides the hardware prerequisites to allow booting the microcontroller from the ETK memory and making the flash accessible to the software while the microcontroller is running from the ETK memory. For braintead flashing it is required that the microcontroller boots from the ETK memory.

When braindead flashing is initiated, the first step is to force the ECU's microcontroller into a reset.

A valid boot programming code will be downloaded into the ETK-T2.2B/ETK-T2.2C. The ETK drives the HWCFG input such that the ECU's microcontroller is configured to external boot. If the Reset signal is deactivated the microcontroller accepts the external Reset Configuration presented on HWCFG. The ECU's microcontroller boots from /CS0 (which is now the ETK CS) and executes the boot programming (recovery) code from the ETK memory (see Fig. 4-3 on page 18).

The external flash is mapped to the ETK Chip Select as set by solder bridge (see Fig. 4-11 on page 27).

The recovery program code accepts data via the ETK mailbox and programs it into the internal or external microcontroller flash. When flash programming is done, the microcontroller must be forced into reset again and the changes done before must be reverted. When reset is released next time, the microcontroller takes its Reset Configuration from the ECU and boots from the standard boot memory (i.e. internal or external Flash) to execute the recently programmed code.

## 4.9 ETK-T2.2 Deactivation

---

It can be necessary that the ETK is deactivated under certain operating conditions, e.g. when an inconsistent data set is detected.

Therefore, the microcontroller can put the ETK-T2.2 into a "switch-off" state. While the ETK is not physically deactivated in this state it pretends being switched off to the calibration system, thus preventing the calibration tool from accessing the ETK. This "switching on" or "switching off" action is accomplished by the ECU writing into specific location (see Fig. 4-5 on page 20) within the trigger segment of the ETK.

Through writing to the address ETK\_Disable (trigger segment address + 0x04h) the "switching off" will be indicated. Through writing to the address ETK\_Enable (trigger segment address) the reactivation of the ETK will be indicated. The data used during the write accesses are meaningless.

### NOTE

---

These two addresses are not protected against accidental write access. Due to the fact that they belong to the trigger segment, they are allocated in the address space of the measurement data memory.

## 4.10 Reset

---

The requirement for ETK reset mechanism is to ensure that power-up and power-down behavior of ECU is clean and smooth and to prevent corruption of data stored in the ETK.

To accomplish this the ETK-T2.2 senses the SVDD of the ECU. This allows it to detect when the ECU is off and forward this information to INCA. In addition, it allows the ETK to enter the power save mode with the CAL tool (ES590/ES591)

unplugged. In addition, the ETK-T2.2 senses the status of the /HDRST line to generate a write protect signal for its memory. Finally, the ETK-T2.2 generates a reset signal by pulling /PORST to keep the ECU in reset while the ETK is in power save mode and to prevent the microcontroller from starting until the ETK is ready to work. The ETK is ready to work when it has finished its initialization after leaving power save mode or after initial power-up. This feature allows it also to reset the ECU under tool control (required for INCA and Prof) and to perform an emergency stop of the ECU in case of ETK failure.

## 4.11 Power Supply

The ETK-T2.2 needs a permanent power supply. It is powered directly from the car battery. The input voltage may vary between 4.3 V and 18 V.

The ECU voltage ( $U_{SG}$ ) is monitored by the ETK to recognize whether the ECU is switched on or off. In case of higher input voltages to the ETK an additional voltage converter is required. All necessary voltages are created through switching power supplies which minimizes heat build-up. The power supply of the ECU is not affected by the ETK-T2.2. An automatic switch ensures that the power supply of the ETK-T2.2 is automatically switched on and off.

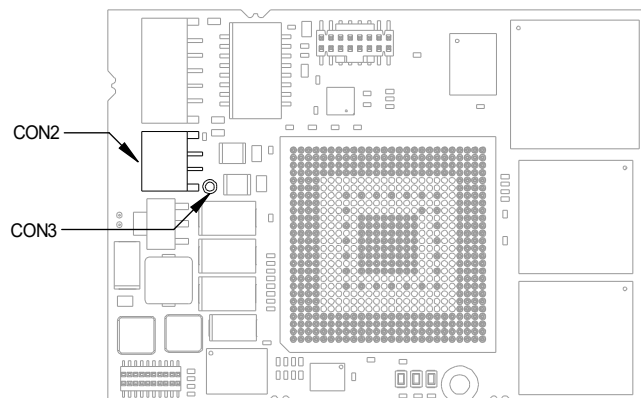

**Fig. 4-6** Power Supply Connectors CON2 and CON3

The ETK-T2.2 can be supplied with power through the 2-pin power supply connector CON2. Additionally the through-hole solder pad CON3 can be used to connect a power supply  $U_{Batt2}$ . The power supply on CON3 must use the GND of CON2.

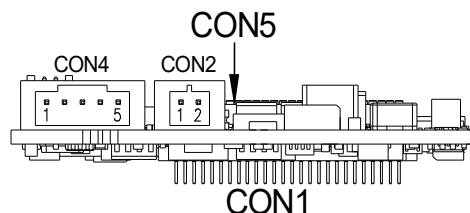

**Fig. 4-7** Power Supply Connector CON2



## 4.12 Serial ETK Interface

The serial 100 MBit/s ETK-T2.2 interface creates the link to the calibration and development system. The interface utilizes a 100Base-TX transmission to achieve an outstanding transmission performance of 100 MBit/s.



### NOTE

To ensure stable communication only 100 Mbit cables delivered by ETAS shall be used.

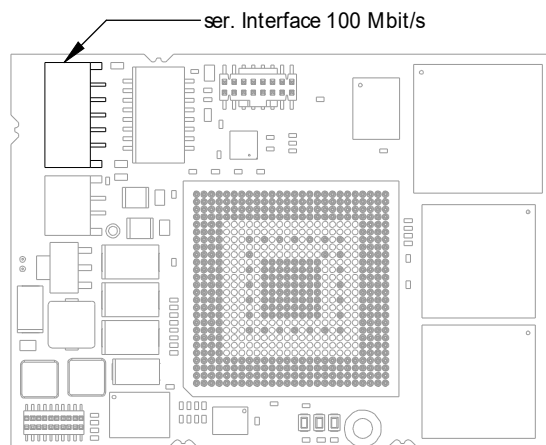

**Fig. 4-8** Location of the Serial ETK Interface

## 4.13 Debug Interface

The ETK-T2.2 features a JTAG debugging interface connector (Samtec 16 pin).

### NOTE

The ETK-T2.2D is delivered without a JTAG debugging interface connector.

This connector can be used to attach debug and trace tools (e.g. Lauterbach or PLS debugger for Infineon TC1792/TC1796).

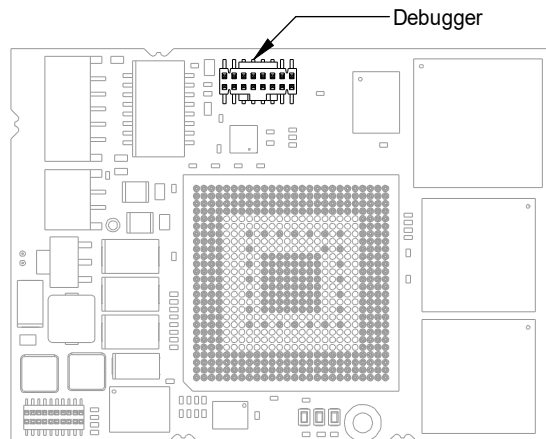
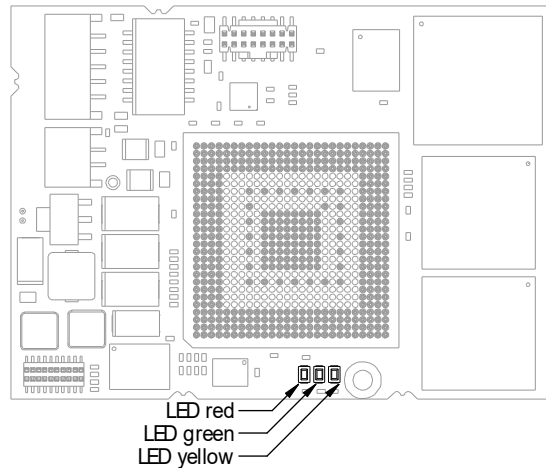

**Fig. 4-9** Location of the Debugger Interface

For connecting the ETK-T2.2 to the debugger the ETK adapter ETAF5 (including ETAF5 PCB and ETAF5 flatcable) is required. Its needs to be ordered separately (refer chapter "Ordering Information" on page 52). A debugger specific cable has to be used to connect the debugger with the ETAF5 PCB.

## 4.14 Status LEDs

There are three LEDs displaying the operating status of the ETK-T2.2 (Fig. 4-10 on page 26).

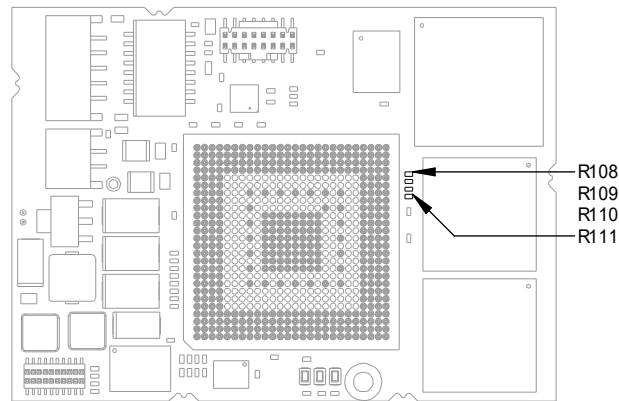

**Fig. 4-10** Status LEDs

LED	State	Meaning
Red	On	ETK-T2.2 is supplied with power and active (i.e. the ECU is switched on or the ETAS calibration and development system is connected and ready to communicate with the ETK-T2.2)
Green	On	When the power supply voltage drops below 3.5 V, the data retention of the DPRs is not longer ensured. As soon as the ETK is switched on again, the content of the ETK-Flash will be copied into reference and working page RAM. The green LED stays lit until the calibration and development system copies new data into RAM.
	Off	Working page may be different to reference page. Working page and reference page may be different to the ETK-Flash.
Yellow	On	100 Mbit/s communication to calibration system established

## 4.15 Chip Select Configuration Bridge

R108 to R111 are alternately assembled to select the ETK chip select signal.



**Fig. 4-11** Chip Select Configuration Bridge

Solder bridge	Meaning
R108	ETK-T2.2 uses /CS1
R109	ETK-T2.2 uses /CS2
R110	ETK-T2.2 uses /CS3
R111	ETK-T2.2 uses /CSCOMB

## 5 Installation

This chapter contains information about the following topics:

- Connection to the ECU . . . . . 28
- Connection to the Debugger . . . . . 29
- Connecting to the Power Supply . . . . . 30

 **CAUTION**

**Some components of the interface board may be damaged or destroyed by electrostatic discharge. Please keep the board in its storage package until it is installed.**

The board should only be taken from its package, configured, and installed at a work place that is protected against static discharge.

### 5.1 Connection to the ECU

 **CAUTION**

**Risk of short circuiting the internal signals of the ETK!**

When you mount the ETK to the ECU, you must ensure that the screws and washers used will not penetrate the ETK printed circuit board.

For mounting the ETK-T2.2 on the ECU an Advanced Interconnect socket is required. It need to be ordered separately (refer chapter "Ordering Information" on page 52).

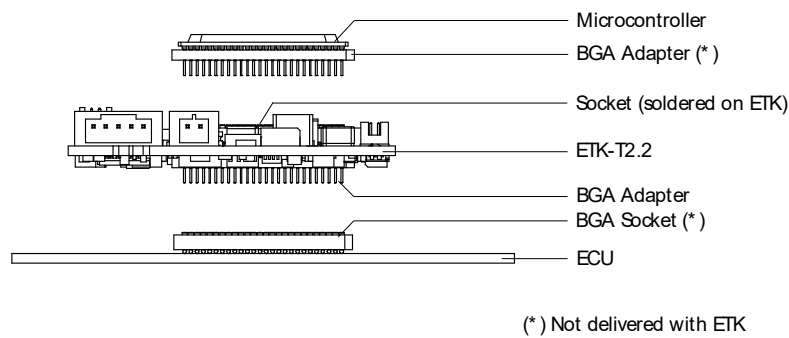

**Fig. 5-1** ETK-T2.2 Connection to the ECU

The ETK-T2.2 board fitted with a "BGA adapter" connector allows connection and removal from an ECU development PCB which has been fitted with a compatible "BGA receiver" socket (see Fig. 5-1).

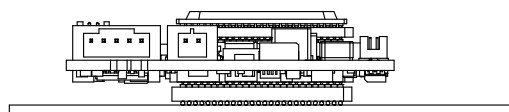
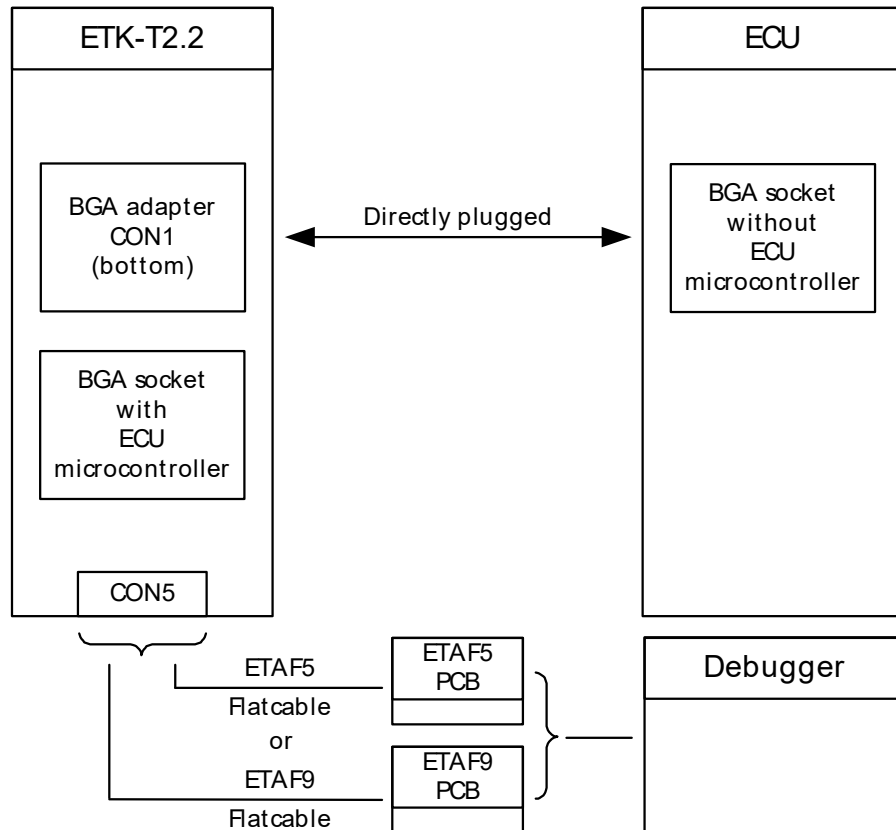

**Fig. 5-2** ETK-T2.2 with Microcontroller mounted on ECU

## 5.2 Connection to the Debugger

For connecting the ETK-T2.2 to the debugger the ETK adapter ETAF9 (including ETAF9 PCB and ETAF9 flatcable) or the ETK adapter ETAF5 (including ETAF5 PCB and ETAF5 flatcable) is required. Its needs to be ordered seperately (refer chapter "Ordering Information" on page 52).

A debugger specific cable has to be used to connect the debugger with the ETAF5 PCB or ETAF9 PCB.



**Fig. 5-3** ETK-T2.2 Connection to the ECU and to the Debugger

### 5.3 Connecting to the Power Supply

The ETK-T2.2 needs a permanent power supply (refer chapter “Power Supply” on page 23). There are different versions to ensure it.

#### 5.3.1 Permanent Power Supply inside ECU available

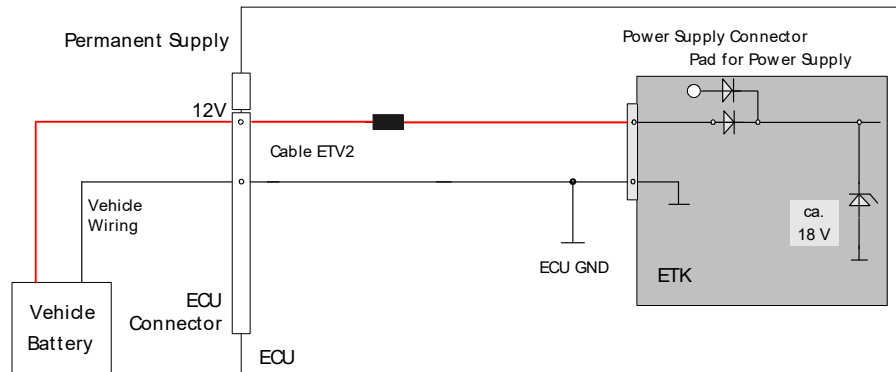

Fig. 5-4 Permanent Power Supply inside ECU available

#### 5.3.2 Permanent Power Supply inside ECU not available

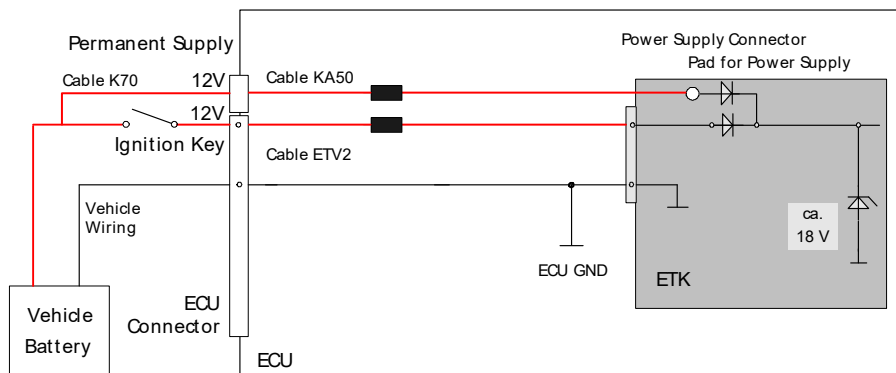

Fig. 5-5 Permanent Power Supply inside ECU not available

#### 5.3.3 Isolated Power Supply inside ECU

The ETK-T2.2 does not require a galvanically isolated power supply. For special applications ETAS offers the isolated power supply ETP2.

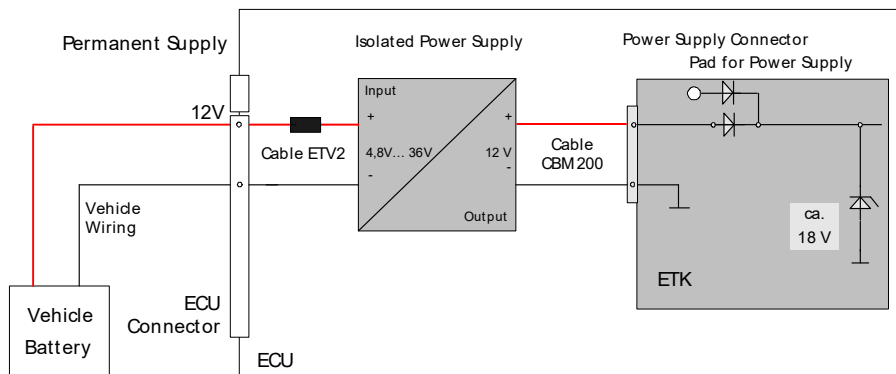

Fig. 5-6 Isolated Power Supply inside ECU

## 6 ETK Configuration

---

This chapter contains information about the following topics:

- Overview ..... 31
- ETK Configuration Tool ..... 31
- Configuration Parameter ..... 32

### 6.1 Overview

---

As already mentioned in previous chapters, some project-specific adjustments are necessary. Configuration data is stored permanently in a serial E<sup>2</sup>PROM.

### 6.2 ETK Configuration Tool

---

Generating a valid configuration data set is supported by the "ETK Configuration Tool". The "ETK Configuration Tool" contains information on all available ETKs. The user is supported through a graphical interface.

The configuration is done in two steps:

- A Generation of the special address offset for the emulation and measurement data memory.

The location of data areas, measured data output areas, trigger segment addresses etc. are familiar to the ECU software developer, or can be generated automatically. If an ECU description database (ASAP, ...) with the corresponding input exists, these inputs can be downloaded from this database. If necessary, a plausibility check is performed.

- B Connection of the ETK to the ECU.

The connection of the ETK to the ECU is defined by the ETK hardware.

The "ETK Configuration Tool" can create the following output:

- A Direct ETK configuration
- B Storage of the configuration in a data file
- C The corresponding ASAP input

The most important outputs are the entries for the ASAP file. The parameter ETK\_CFG is created and contains the complete ETK configuration of the ECU interface in hex code. If this parameter is entered correctly in the corresponding ECU description file, it guarantees that every time the calibration system is started, the ETK is checked for the appropriate configuration. If necessary, the ETK will be configured appropriately to the corresponding project.



## 6.3 Configuration Parameter

The configuration of the ETK-T2.2 is possible with the "ETK Configuration Tool". Not all combinations of parameters make sense. The "ETK Configuration Tool" provides support concerning the configuration parameters. The following is a list with configuration parameters:

- BDF is supported by ETK Hardware (Yes, No)

The default value is "No".

Some assembly variants of the ETK have the capability to flash an ECU even if the ECU does not contain any useful code (the ECU is "brain dead", Brain Dead Flashing). This feature can only be configured if no ETK is connected. As soon as an ETK is connected, the ETK Configuration Tool detects automatically if the connected variant supports BDF.

- Exchange CS of ETK and Flash (Yes, No)

The default value is "No".

During the flashing it is necessary that the ETK places its memory to the location where normally the flash is located. This allows to execute a program from the ETK memory which contains a boot loader. This reconfiguration is done during the flashing script.

- ETK drive HWCFG[0:3] Signals (Yes, No)

The default value is "No".

During flashing it is necessary that way the microcontroller boots is controlled by the ETK. This is done by driving the HWCFG signals.



### NOTE

The above mentioned features make only sense during the reprogramming of the ECU Flash. In the script used for flashing the ETK gets reconfigured. For normal operation with INCA this settings are always set back to default to avoid unexpected behaviour of INCA.

- ETK is used as (ETK-T2.2, ETK-T2.0, ETK-T1.1, ETK-T1.0)

The default value is "ETK-T2.2".

The ETK-T2.2 can act as ETK-T2.0, ETK-T1.1 or ETK-T1.0.

The ETK-T2.2 and the ETK-T2.0 has more memory and additional features (like BDF for any versions) that are not available for ETK-T1.0 or ETK-T1.1. For projects which are using older INCA version the ETK-T2.2 and the ETK-T2.0 can act like one of the old ETKs without any changes in the PC software, but with only the capabilities of the old ETKs.

- BDF is supported by ETK Hardware (Yes, No)

The default value (online) depends on used ETK.

The default value (offline) is "No".

- Exchange CS of ETK and FLASH (Yes, No)

The default value is "No".

- HWCFG Signal Group (HWCFG [3:0] for TC1796 or HWCFG [7:0] for TC1797, No)

The default value is "No".

- ETK drives HWCFG Signals (boot mode depends on selected microcontroller, No)

The default value is "No".

**NOTE**

The above mentioned features need not to be modified for normal operation of the ETK. They are only intended for the very experienced user and thus only visible when the extended mode in the options menu of the ETK Configuration mode is set.

## 7 Technical Data

This chapter contains information about the following topics:

- ETK-T2.2 Versions ..... 34
- System Requirements ..... 34
- Environmental Conditions ..... 36
- Power Supply ..... 36
- Memory and Configuration ..... 36
- Serial ETK Interface ..... 37
- Microcontroller Bus Interface ..... 37
- Test characteristics ..... 37
- Electrical Characteristics ..... 38
- Switching Characteristics ..... 41
- Power Supply Connector CON2 ..... 42
- Mechanical Dimensions ..... 42

### 7.1 ETK-T2.2 Versions

The ETK-T2.2 can be ordered in different functional and mechanical versions:

ETK-T2.2 Version	Braided Flash Support	PCB with Mounting Holes	Directly soldered Microcontroller
ETK-T2.2A	No	No	No
ETK-T2.2B	Yes	No	No
ETK-T2.2C	Yes	Yes	No
ETK-T2.2D	No	No	Yes <sup>1)</sup>

<sup>1)</sup>: Microcontroller provided by customer

### 7.2 System Requirements

#### 7.2.1 ETAS Hardware

VME Hardware: ES1000.2/ES1000.3 with ES1232 (INCA/ASCET)

Compact Hardware: ES590, ES591, ES592 (INCA)

Compact Hardware: ES910 (INTECRIO)

#### 7.2.2 PC with one Ethernet Interface

A PC with one open Ethernet interface (1 Gbit/s) with RJ-45 connection is required to connect the ES89x module. Ethernet interfaces that are implemented with an additional network card in the PC must feature a 32-bit data bus.

### 7.2.2.1 Requirement to ensure successful Initialization of the Module

**NOTE**

It is imperative you disable the function which automatically switches to power-saving mode on your PC network adapter when there is no data traffic on the Ethernet interface!

#### To deactivate the Power saving Mode

Choose in Windows System Control Center / Device Manager / Network Adapter the used network adapter by double-click. Deactivate the "Allow the computer to turn off this device to save power" option in the "Power Management" register. Confirm your configuration.

The manufacturers of network adapter have different names for this function.

Example:

- "Link down Power saving"
- "Allow the computer to turn off this device to save power"

### 7.2.3 Software and supported Microcontrollers

You need following software versions to support the ETK-T2.2:

Micro-controller	HSP	INCA	ETK Drivers and Tools	ASCET-RP	INTECRIO
TC1792	V8.1.0	V5.4 .0	n.a.	V5.4	V1.1
TC1793, TC1793ED	V8.1.0	V6.2.1 <sup>1)</sup>	V2.1.7	V5.4	V1.1
TC1796, TC1796ED	V8.1.0	V5.4.0	n.a.	V5.4	V1.1
TC1797, TC1797ED <sup>2)</sup>	V8.1.0	V5.4.0	n.a.	V5.4	V1.1
TC1797, TC1797ED <sup>3)</sup>	V8.1.0	V6.1	V1.1.2	V5.4	V1.1

<sup>1)</sup> INCA V5.4 usage also supported with ETK-T2.1 Config String in A2L file

<sup>2)</sup> Operating measurement and calibration, no Braindead Flashing

<sup>3)</sup> Operating measurement, calibration, and Braindead Flashing

Operating the ETK-T2.2 with older software versions is not possible.

### 7.3 Environmental Conditions

Item	Characteristics
Temperature range (operation)	- 40 °C to +110 °C/ - 40 °F to +230 °F
Temperature range (storage)	0 °C to +50 °C/ - 18 °F to +122 °F
Relative humidity (non-condensing)	0 to 95%
Operating altitude	max. 5000 m/ 16400 ft
Contamination level	2
Degree of protection	Determined by installation in ECU
Overvoltage category (AC mains supply)	II

### 7.4 Power Supply

Parameter	Symbol	Condition	Min	Typ	Max	Unit
Permanent power supply (car battery)	$U_{\text{Batt}}$	Vehicle usage <sup>1)</sup>	4.3	12	18	V
			[all values $\pm 0\%$ ]			
Standby current	$I_{\text{STBY}}$	$U_{\text{Batt}} = 12 \text{ V};$ ECU off; $T = 20 \text{ °C}$	1	10	30	mA
Operating current	$I_{\text{Batt}}$	$U_{\text{Batt}} = 12 \text{ V};$ ECU on; $T = 20 \text{ °C}$	20	60	110	mA
Power dissipation	$P_{\text{Batt}}$	$U_{\text{Batt}} = 12 \text{ V};$ ECU on; $T = 20 \text{ °C}$		0.72		W

1) The ETK-T2.2 implements reverse voltage protection in the same range and may be used only with central load dump protection.

### 7.5 Memory and Configuration

Item	Characteristics
Emulation Memory	Two memory pages with 1024 kB data memory each
Measured Memory	Within the Emulation Memory, free configurable
Flash Memory	1024 kB Flash (data)
Configuration	Project-specific; stored in EEPROM for different microcontrollers and memory configurations
Update	Logic devices updated through software

## 7.6 Serial ETK Interface

Item	Characteristics
Transmission speed	100 Mbit/s
Cable length	max. 30 m / 100 ft
Serial Interface	DC decoupling

## 7.7 Microcontroller Bus Interface

Parameter	Symbol	Condition	Min	Typ	Max	Unit
ECU Supply Voltage - Power Detect	$V_{DD}$	ECU on	0.92	1.02	1.12	V
		ECU off	0.84	0.94	1.04	V
max. load	$I_{DD}$				0.1	mA
max. load $V_{DDEBU}$	$I_{DDEBU}$				2	mA

## 7.8 Testcharacteristics

Parameter	Symbol	Condition	Min	Max	Unit
Reset delay 1	$t_{Reset1}$	$U_{Batt}=12\text{ V}$ $U_{SG}=0\text{ V} \uparrow > 3.3\text{ V}$ without transferring Flash	29	40	ms
Reset delay 2	$t_{Reset2}$	$U_{Batt}=12\text{ V}$ $U_{SG}=0\text{ V} \uparrow 3.3\text{ V}$ with transferring Flash	79	100	ms
Reset delay 3	$t_{Reset3}$	$U_{Batt1}=0\text{ V} \uparrow 12\text{ V}$ transfer FPGA and Flash	310	350	ms



### NOTE

$t_{Reset1}$ : Delay of ECU reset through ETK without transferring the Flash ( $U_{Batt1}$  present, USG will be switched on)

$t_{Reset2}$ : Delay of ECU reset through ETK with transferring the Flash ( $U_{Batt1}$  present, transfer active, USG will be switched on)

$t_{Reset3}$ : max. delay of ECU reset through ETK ( $U_{Batt1}$  and USG will be switched on)

## 7.9 Electrical Characteristics

### 7.9.1 With Braindead Flashing (ETK-T2.2B and ETK-T2.2C)

Signal	Condition	Pin Type	$V_{OL}$ (max) [V]	$V_{OH}$ (min) [V]	$V_{OH}$ (max) [V]	$V_{IL}$ (max) [V]	$V_{IH}$ (min) [V]	$V_{IH}$ (max) [V]	Leakage current [ $\mu$ A]	Additional Load by ETK (typ) [pF] <sup>(1)</sup>
ADDR[1...0]		I	-	-	-	0.8	2	3.6	-10/+10	15
ADDR[19...2]		I	-	-	-	0.8	2	3.6	-30/+30	31
DATA[31..0]	ETK is not accessed	I	-	-	-	-	-	3.6	-1/+1	7
	ETK is accessed; $I_{OH} = 4$ mA; $I_{OL} = 4$ mA	I/O	0.4	2.2	2.9	0.8	2	3.6	-22/+22	40
/CS0	Used by ECU	I	-	-	-	-	-	3.6	-3/-3	24
	Used for ETK	I	-	-	-	0.8	2	3.6	-300/-360	59
/CS[3..1], /CSCOMB	Used by ECU	I	-	-	-	-	-	-	-	1
	Used for ETK	I	-	-	-	0.8	2	3.6	-300/-360	59
RD_/WR;/BC[3..0]		I	-	-	-	0.8	2	3.6	-30/+30	28
/RD		I	-	-	-	0.8	2	3.6	-680/-710	34

Signal	Condition	Pin Type	$V_{OL}$ (max) [V]	$V_{OH}$ (min) [V]	$V_{OH}$ (max) [V]	$V_{IL}$ (max) [V]	$V_{IH}$ (min) [V]	$V_{IH}$ (max) [V]	Leakage current [ $\mu$ A]	Additional Load by ETK (typ) [pF] <sup>1)</sup>
HWCFG96[3..0]	CPU side activ; $I_{OH} = 4$ mA; $I_{OL} = 4$ mA	0	0.45	2.4	3.3	-	-	-	-	20
	ECU side activ	I	-	-	-	-	-	4.1	-1/+1	10
	inactiv	I	-	-	-	-	-	4.1	-12/+12	25
HWCFG97[7..0]	CPU side activ; $I_{OH} = 4$ mA; $I_{OL} = 4$ mA	0	0.45	2.4	3.3	-	-	-	-	25
	ECU side activ	I	-	-	-	-	-	4.1	-1/+1	10
	inactiv	I	-	-	-	-	-	4.1	-12/+12	30
/PORESET	$I_{Dmax} = 0.2$ A	I/OD	0.4	-	-	0.8	2	3.6	-20/+20	40
/HDRESET		I	-	-	-	0.8	2	3.6	-10/+10	15

<sup>1)</sup> CPU and plug not considered; PCB 1 pF/cm



## 7.9.2 Without Braindead Flashing (ETK-T2.2A)

Signal	Condition	Pin Type	$V_{OL}$ (max) [V]	$V_{OH}$ (min) [V]	$V_{OH}$ (max) [V]	$V_{IL}$ (max) [V]	$V_{IH}$ (min) [V]	$V_{IH}$ (max) [V]	Leakage current [ $\mu$ A]	Additional Load by ETK (typ) [pF] <sup>1)</sup>
ADDR[1...0]		I	-	-	-	0.8	2	3.6	-10/+10	15
ADDR[19...2]		I	-	-	-	0.8	2	3.6	-30/+30	31
DATA[31..0]	ETK is not accessed	I	-	-	-	-	-	3.6	-1/+1	7
	ETK is accessed; $I_{OH} = 4$ mA; $I_{OL} = 4$ mA	I/O	0.4	2.2	3.3	0.8	2	3.6	-22/+22	40
/CS[3..0], /CSCOMB	Used by ECU	I	-	-	-	-	-	-	-	1
	Used for ETK	I	-	-	-	0.8	2	3.6	-300/-360	36
RD_/WR; /BC[3..0]		I	-	-	-	0.8	2	3.6	-30/+30	28
/RD		I	-	-	-	0.8	2	3.6	-680/-710	34
HWCFG96[3..0]		-	-	-	-	-	-	-	-	3
HWCFG97[7..0]		-	-	-	-	-	-	-	-	6
/PORESET	$I_{Dmax} = 0.2$ A	I/OD	0.4	-	-	0.8	2	3.6	-20/+20	40
/HDRESET		I	-	-	-	0.8	2	3.6	-10/+10	15

<sup>1)</sup> CPU and plug not considered; PCB 1 pF/cm

## 7.10 Switching Characteristics

The ETK-T2.2A, the ETK-T2.2B and the ETK-T2.2C have the same timing.

The following diagrams show the timings the ETK-T2.2 can process.

Para.	Description	Min	Max	Unit
t <sub>1</sub>	Address access time		15	ns
t <sub>2</sub>	Chip select access time		15	ns
t <sub>3</sub>	Read access time		10	ns
t <sub>4</sub>	Byte enable access time		10	ns
t <sub>5</sub>	Data to Chip select hold time		8	ns
t <sub>6</sub>	Data to Read hold time		8	ns
t <sub>7</sub>	Data to Byte enable hold time		8	ns
t <sub>10</sub>	Chip select setup to end of write	18		ns
t <sub>11</sub>	Write pulse width	12		ns
t <sub>12</sub>	Data setup to end of write	10		ns
t <sub>13</sub>	Data hold from end of write	2		ns



### NOTE

All timings are measured at a reference level of 1.5 V. Output signals are measured with 10 pF to ground and 50 Ω to 1.5 V.

### 7.10.1 Read Timing: Data Emulation and Measurement Data DPR

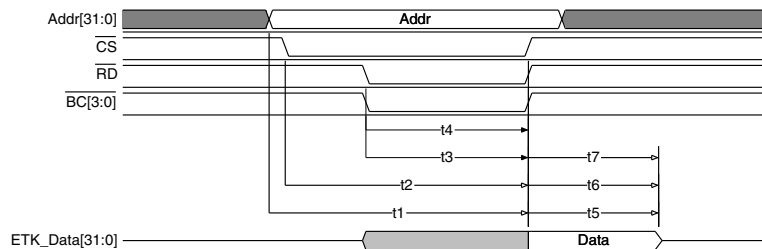

Fig. 7-1 Read Cycle: Data Emulation and Measurement Data DPR

### 7.10.2 Write Timing: Data Emulation and Measurement Data DPR



Fig. 7-2 Write Cycle: Data Emulation and Measurement Data DPR

### 7.11 Power Supply Connector CON2

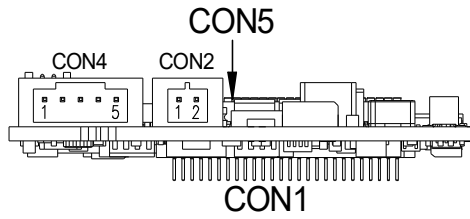

**Fig. 7-3** Power Supply Connector CON2

Pin CON2	Signal	Description
1	U <sub>Batt1</sub>	Battery Supply Voltage for ETK
2	GND	Ground

### 7.12 Mechanical Dimensions

The reference measure for all drawings is millimeter.

Dimensions	Millimeters	Inches
Thickness of PCB	1.70	0.067
Height of component (upper side)	5.50	0.217
Height of component (lower side)	2.00	0.079

#### 7.12.1 ETK-T2.2A and ETK-T2.2B

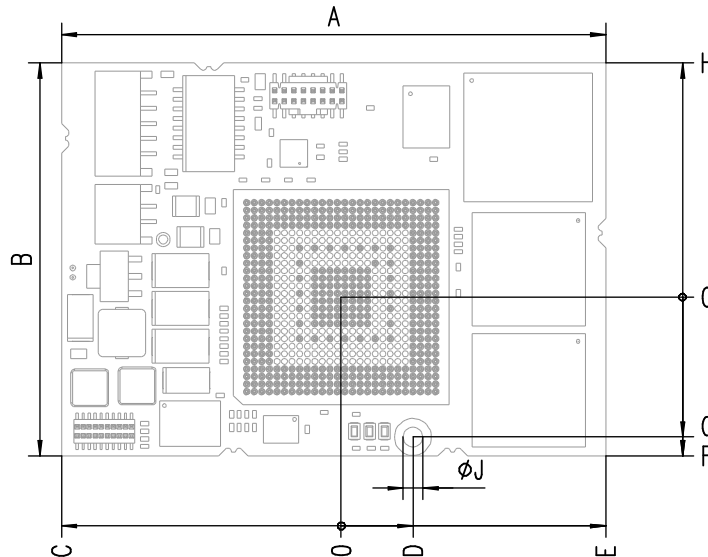

**Fig. 7-4** ETK-T2.2A and ETK-T2.2B Dimensions - Top View

Dim	Millimeters	Inches	Dim	Millimeters	Inches
A	72.00	2.835	F	21.00	0.827
B	52.00	2.047	G	18.50	0.728
C	37.00	1.457	H	31.00	1.220
D	9.50	0.374	J	2.60	0.102
E	35.00	1.378			

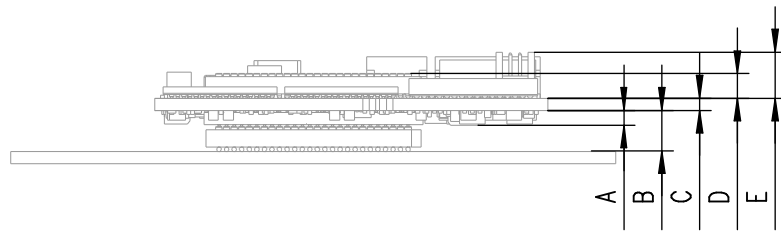

**Fig. 7-5** Microcontroller with Socket Adapter mounted (ETK-T2.2A and ETK-T2.2B)

For mounting the ETK on the ECU, and for mounting the MPC on the ETK, the Advanced Interconnect Socket is required (see ordering information).

Dim	Millimeters	Inches
A	2.00	0.079
B	5.36	0.211
C	1.70	0.067
D	3.28	0.129
E	5.50	0.217

7.12.2 ETK-T2.2C

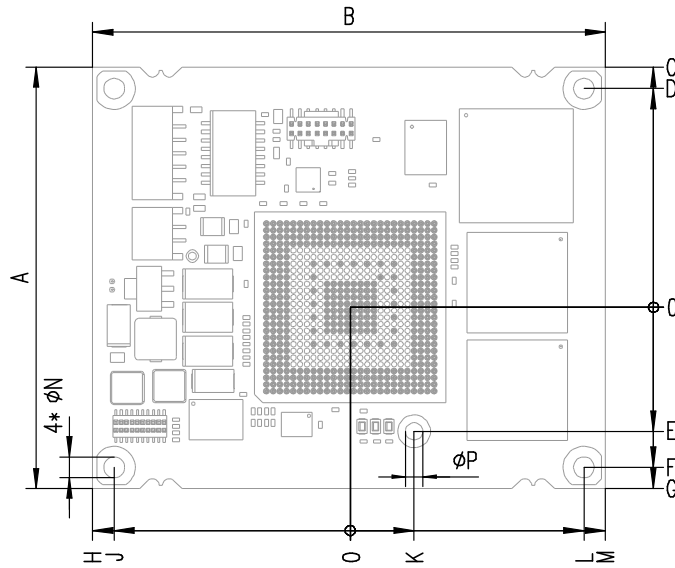

Fig. 7-6 ETK-T2.2C Dimensions - Top View

Dim	Millimeters	Inches	Dim	Millimeters	Inches
A	62.90	2.476	H	38.40	1.512
B	76.40	3.008	J	35.20	1.386
C	35.84	1.411	K	9.50	0.374
D	32.64	1.285	L	34.80	1.370
E	18.50	0.728	M	38.00	1.496
F	23.86	0.939	N	3.20	0.126
G	27.06	1.065	P	2.70	0.106

7.12.3 ETK-T2.2D

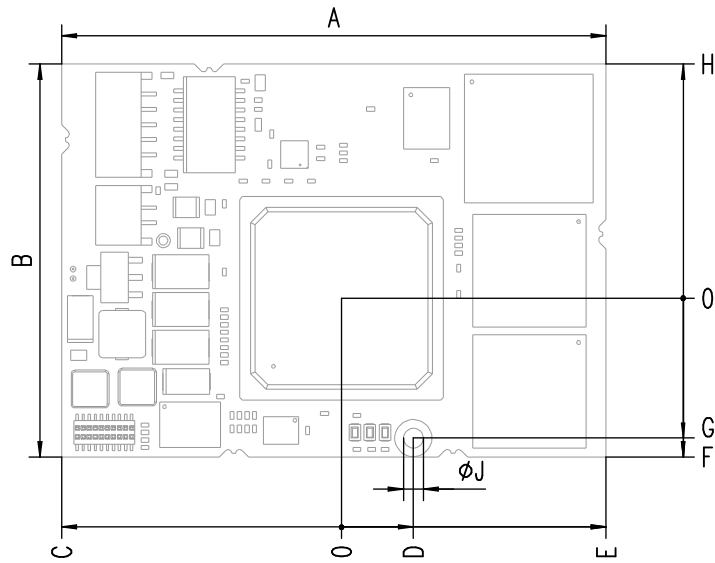

Fig. 7-7 ETK-T2.2D Dimensions - Top View

Dim	Millimeters	Inches	Dim	Millimeters	Inches
A	72.00	2.835	F	21.00	0.827
B	52.00	2.047	G	18.50	0.728
C	37.00	1.457	H	31.00	1.220
D	9.50	0.374	J	2.60	0.102
E	35.00	1.378			

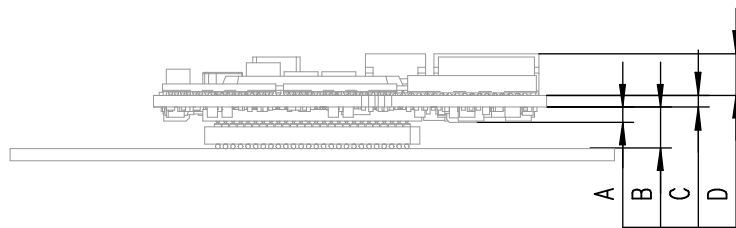

Fig. 7-8 Microcontroller directly soldered (ETK-T2.2D).

Dim	Millimeters	Inches
A	2.00	0.079
B	5.36	0.211
C	1.70	0.067
D	3.28	0.129
E	5.50	0.217

## 8 Cables and Accessories

### 8.1 Interface Cables

#### 8.1.1 Cable KA54 (with PG Cable Gland)

**NOTE**  
 Cable glands are not included in the delivery. Refer to the cable descriptions for manufacturers and order numbers.

#### Cable KA54, Proposal 1

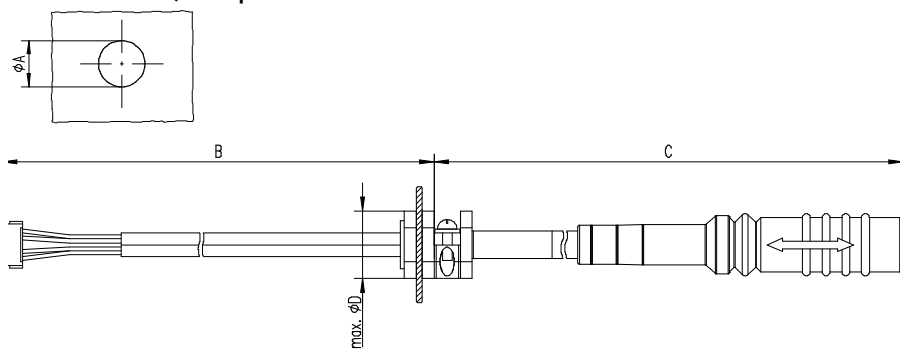

**Fig. 8-1** Interface Cable KA54, Proposal 1

Dim	Millimeters	Inches	Dim	Millimeters	Inches
A	12.50	0.492	C	400.00	15.748
B	160.00	6.299	D	19.00	0.748

**NOTE**  
 Shield connected to ECU housing.

*SKINDICHT compact screwing; Manufacturer: Lapp; Description: SH7; Order-No.: 5200 0830*

*Nut for compact screwing; Manufacturer: Lapp; Description: SM7; Order-No.: 5200 3490*

Cable KA54, Proposal 2

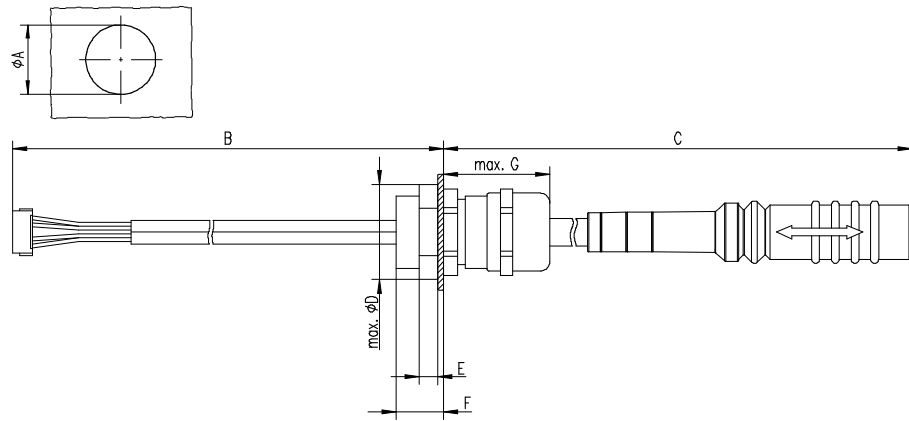

Fig. 8-2 Interface Cable KA54, Proposal 2

Dim	Millimeters	Inches
A	18.80	0.740
B	160.00	6.299
C	400.00	15.748
D	24.25	0.955
E	4.70	0.185
F	12.00	0.472
G	27.00	1.063



**NOTE**

Shield connected to ECU housing.

SKINTOP compact screwing; Manufacturer: Lapp; Description: MS-SC 11 ; Order-No.: 5311 2320

Nut for compact screwing; Manufacturer: Lapp; Description: SM-PE 11 ; Order-No.: 5210 3220



## 8.2 Cable KA55

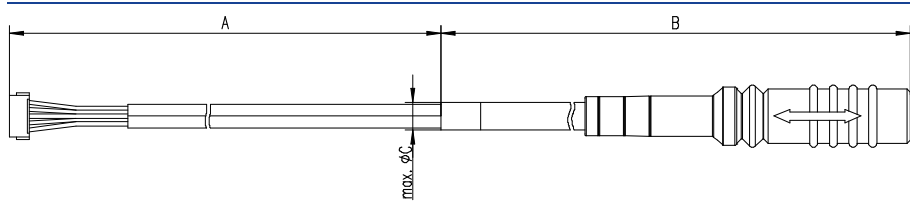

**Fig. 8-3** Interface Cable KA55

Dim	Millimeters	Inches
A	160.00	6.299
B	400.00	15.748
C	9.00	0.3543



**NOTE**

Strain relief on ECU cover necessary. Shield not connected to ECU housing.

### 8.2.1 Cable CBAM200

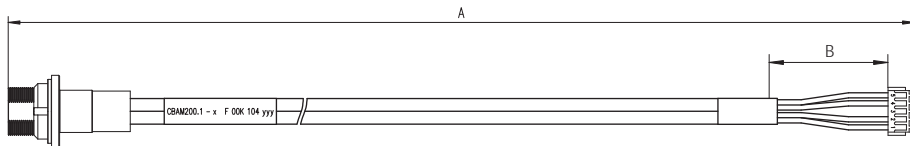

**Fig. 8-4** Interface Cable CBAM200-0m38

Dim	Millimeters	Inches
A	380.00	14.96
B	30.00	1.18



**NOTE**

Shield connected to ECU housing, allows for ECU housing flush mounting.

## 8.3 Power Supply Cables

### 8.3.1 Cable ETV

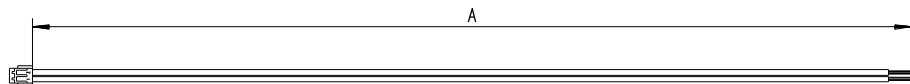

**Fig. 8-5** Power Supply Cable ETV

Dim	Millimeters	Inches
A	190.00	7.480

### 8.3.2 Cable with Filtercoil ETV2

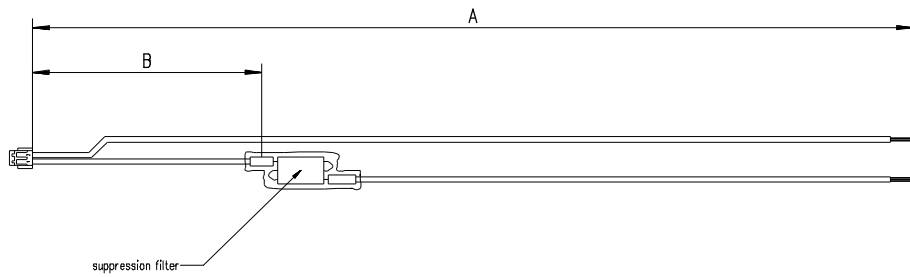

**Fig. 8-6** Power Supply Cable with Filtercoil ETV2

Dim	Millimeters	Inches
A	190.00	7.480
B	50.00	1.969

### 8.3.3 Cable K70

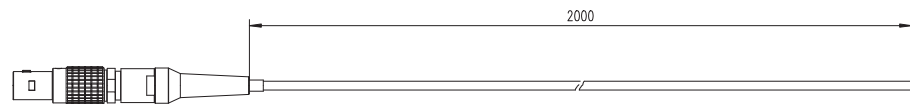

**Fig. 8-7** Power Supply Cable K70

Dim	Millimeters	Inches
A	2000	78.74

### 8.3.4 Cable KA50

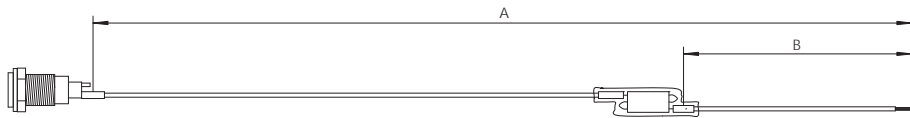

**Fig. 8-8** Power Supply Cable KA50

Dim	Millimeters	Inches
A	200	7.87
B	50	1.97

### 8.3.5 Cable CBM200

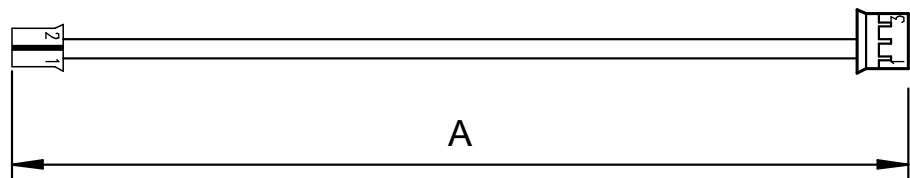
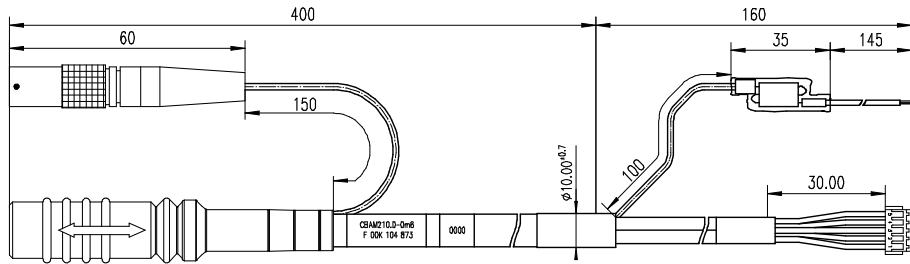

**Fig. 8-9** Power Supply Cable CBM200

Dim	Millimeters	Inches
A	100	3.94

## 8.4 Combined Interface and Power Supply Cables

### 8.4.1 Cable CBAM210

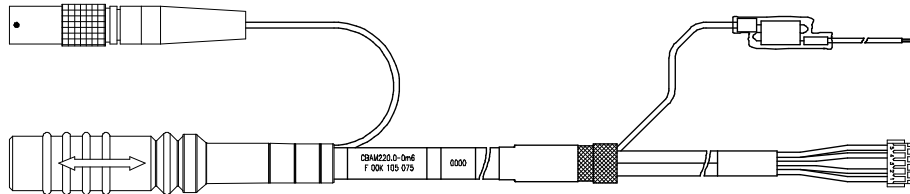

**Fig. 8-10** Combined Interface and Power Supply Cable CBAM210

**NOTE**

Shield not connected to ECU housing.

### 8.4.2 Cable CBAM220



**Fig. 8-11** Combined Interface and Power Supply Cable CBAM220

For cable CBAM220 dimensions refer to dimensions of cable CBAM210 in Fig. 8-10.

**NOTE**

Shield connected to ECU housing.

## 8.5 Adapters

### 8.5.1 Debug Adapter ETAF5

#### ETAF5 PCB

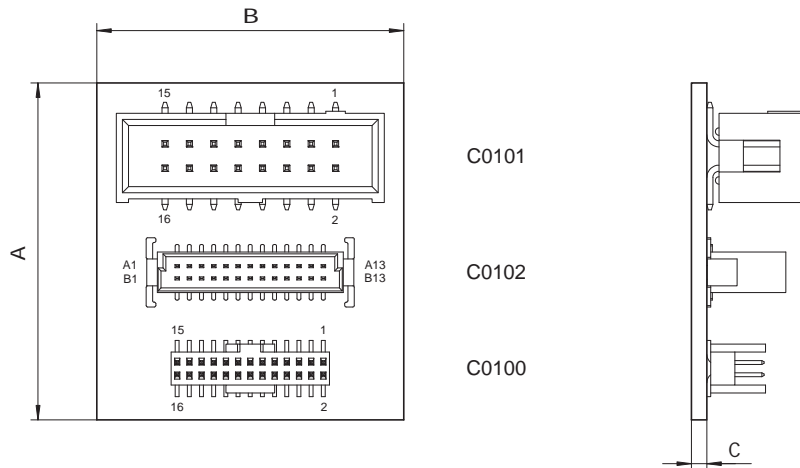
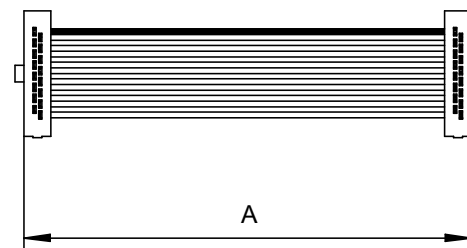

**Fig. 8-12** ETAF5 - Mechanical Dimensions and Component Placement

Dim	Millimeters	Inches
A	35.00	1.38
B	32.00	1.26
C	1.60	0.06

Connector	Description
C0100	to ETK Debug Connector
C0101	to Debugger
C0102	to ECU

#### ETAF5 Flatcable

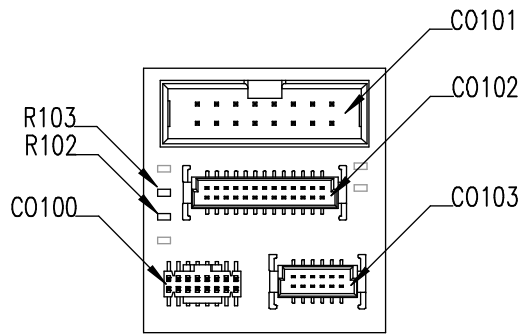

**Fig. 8-13** ETAF5 Flatcable

Dim	Millimeters	Inches
A	50.80	2.00

### 8.5.2 Debug Adapter ETAF9

#### ETAF9 Component Placement



**Fig. 8-14** ETAF9 Component Placement

#### ETAF9 PCB

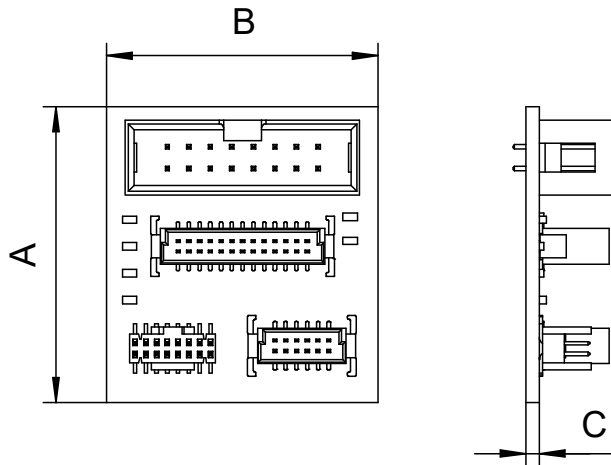

**Fig. 8-15** ETAF9 - Mechanical Dimensions and Component Placement

Dim	Millimeters	Inches
A	35.00	1.38
B	32.00	1.26
C	1.60	0.06

#### ETAF9 Flatcable

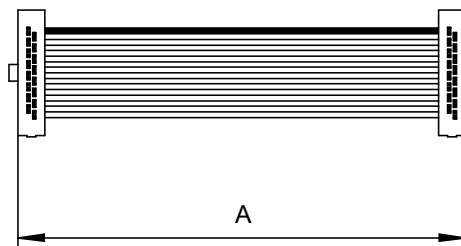

**Fig. 8-16** ETAF9 Flatcable

Dim	Millimeters	Inches
A	50.80	2.00

## 9 Ordering Information

---

### 9.1 ETK-T2.2

---

#### 9.1.1 ETK-T2.2A

Order Name	Short Name	Order Number
ETK-T2.2 with 441 pin $\mu$ C socket and 441 pin adapter for TC1792, TC1793(ED), TC1796(ED) and TC1797(ED) ECUs; without BDF	ETK-T2.2A	F 00K 107 061
<b>Package Contents</b>		
<ul style="list-style-type: none"> <li>• ETK-T2.2A Emulator Probe for the Infineon AURIX microprocessor family</li> <li>• List "Content of this Package"</li> <li>• ETK Safety Advice</li> <li>• China-RoHS-leaflet_Compact_cn</li> </ul>		

#### 9.1.2 ETK-T2.2B

Order Name	Short Name	Order Number
ETK-T2.2 with 441 pin $\mu$ C socket and 441 pin adapter for TC1792, TC1793(ED), TC1796(ED) and TC1797(ED) ECUs; with BDF support	ETK-T2.2B	F 00K 107 062
<b>Package Contents</b>		
<ul style="list-style-type: none"> <li>• ETK-T2.2B Emulator Probe for the Infineon AURIX microprocessor family</li> <li>• List "Content of this Package"</li> <li>• ETK Safety Advice</li> <li>• China-RoHS-leaflet_Compact_cn</li> </ul>		

#### 9.1.3 ETK-T2.2C

Order Name	Short Name	Order Number
ETK-T2.2 with 441 pin $\mu$ C socket and 416 pin adapter for TC1792, TC1793(ED), TC1796(ED) and TC1797(ED) ECUs; with BDF support; with mounting holes for secure fit in harsh environments	ETK-T2.2C	F 00K 107 063
<b>Package Contents</b>		
<ul style="list-style-type: none"> <li>• ETK-T2.2C Emulator Probe for the Infineon AURIX microprocessor family</li> <li>• List "Content of this Package"</li> <li>• ETK Safety Advice</li> <li>• China-RoHS-leaflet_Compact_cn</li> </ul>		

### 9.1.4 ETK-T2.2D

Order Name	Short Name	Order Number
ETK-T2.2D emulator probe with 416 pin adapter for a TC1797ED ECU, without socket, 1 MB memory / page	ETK-T2.2D	F 00K 107 064
<b>Package Contents</b>		
<ul style="list-style-type: none"> <li>• ETK-T2.2A Emulator Probe for the Infineon AURIX microprocessor family</li> <li>• List "Content of this Package"</li> <li>• ETK Safety Advice</li> <li>• China-RoHS-leaflet_Compact_cn</li> </ul>		

## 9.2 ECU/ETK Sockets and Adapters

Sockets are available from local Advanced Interconnect distributors.

### 9.2.1 Socket ECU - ETK

ECU Controller	ECU Socket
TC1792, TC1793(ED), TC1796, TC1797(ED)	Advanced Interconnect Socket 5FHSB416-716GG (416 pins)
TC1796ED	Advanced Interconnect Socket 7632TR (441 pins)

### 9.2.2 BGA Adapter ETK - Microcontroller

Controller	Adapter
TC1792, TC1793(ED), TC1796, TC1797(ED)	Advanced Interconnect BGA Adapter 5FHAX416-715GG (416 pins)
TC1796ED	Advanced Interconnect BGA Adapter 7633 (441 pins)

## 9.3 Debug Adapter

Order Name	Short Name	Order Number
Debug Adapter from Infineon OCDS1-Plug to ETK (ETAF5 PCB and ETAF5 Flat Cable)	ETAF5	F00K 104 220
Debug Adapter from Infineon OCDS1-Plug to ETK (ETAF9 PCB and ETAF9 Flat Cable)	ETAF9	F00K 105 897

## 9.4 Cables

Please contact your local ETAS representative for further cable information.

### 9.4.1 Power Supply Cables

Order Name	Short Name	Order Number
Cable JST PHR - JST PHR (2fc-3fc), 0m1	CBM200-0m1	F 00K 900 052
ETK Power Supply Cable, JST PHR - open wires (2fc-2c) 0m19	ETV	Y 261 A24 446
ETK Power Supply Cable with Filter Coil, JST PHR open wires (2fc-2c), 0m19	ETV2	F 00K 000 593
External Power Supply Cable for ETKs, Lemo 0B FGG - open wires (2fc-1c), 2 m	K70	Y 261 A24 942
ETK Power Supply Cable for External Supply, with Filter Coil, Lemo 0B EGG open wire (2fc-1c), 0m2	KA50	F 00K 000 940

### 9.4.2 Combined Interface and Power Supply Cables

Order Name	Short Name	Order Number
ETK ECU Adapter and Power Supply Cable, Lemo 1B PHG - JST PHR (4fc-5fc) / Lemo 0B PHG - open wires (2fc-2c), 0m6	CBAM210-0m6	F 00K 104 873
ETK ECU Adapter and Power Supply Cable, Shield on ECU-Housing, Lemo 1B PHG - JST PHR (4fc-5fc) / Lemo 0B PHG - open wires (2fc-2c), 0m60	CBAM220-0m6	F 00K 105 075

### 9.4.3 Interface Cables

Order Name	Short Name	Order Number
ETK ECU Adapter Cable, Shield on ECU-Housing, Lemo 1B PHG JST PHR (4fc-5fc), 0m6 <sup>1)</sup>	KA54	F 00K 001 302
ETK ECU Adapter Cable, Lemo 1B PHG JST PHR (4fc-5fc), 0m6 <sup>2)</sup>	KA55	F 00K 001 303
ETK ECU Adapter Cable, Shield on ECU-housing, Lemo 1B HMG JST PHG (4fc-5fc), 0m130	CBAM200-0m130	F 00K 104 852
ETK ECU Adapter Cable, Shield on ECU-housing, Lemo 1B HMG JST PHG (4fc-5fc), 0m38	CBAM200-0m38	F 00K 104 330
ETK ECU Adapter Cable, Shield on ECU-housing, Lemo 1B HMG JST PHG (4fc-5fc), 0m085	CBAM200-0m085	F 00K 104 312
ETK ECU Adapter Cable, Shield on ECU-housing, Lemo 1B HMG JST PHG (4fc-5fc), 0m115	CBAM200-0m115	F 00K 104 311

<sup>1)</sup>: ETK grounded via ECU housing

<sup>2)</sup>: ETK grounded via cable



## 9.5 Power Supply

---

Order Name	Short Name	Order Number
ETK power supply for 6-36V DC input	ETP1	F 00K 000 624
ETP2 Power Supply Interface for ETK	ETP2	F 00K 104 010

## 10 Contact Information

---

### ETAS Headquarters

ETAS GmbH

Borsigstraße 24  
70469 Stuttgart  
Germany

Phone: +49 711 3423-0  
Fax: +49 711 3423-2106  
Internet: [www.etas.com](http://www.etas.com)

### ETAS Subsidiaries and Technical Support

For details of your local sales office as well as your local technical support team and product hotlines, take a look at the ETAS website:

ETAS subsidiaries            Internet: [www.etas.com/en/contact.php](http://www.etas.com/en/contact.php)  
ETAS technical support    Internet: [www.etas.com/en/hotlines.php](http://www.etas.com/en/hotlines.php)

## Figures

---

Fig. 2-1	Adhesive Label (Example: Label for XETK-S14.0)	11
Fig. 2-2	WEEE-Symbol	12
Fig. 3-1	ETK-T2.2A/ ETK-T2.2B (left) and ETK-T2.2C (right)	14
Fig. 4-1	ETK-T2.2 Architecture	16
Fig. 4-2	ETK-T2.2A, ETK-T2.2D: internal and external Memory	18
Fig. 4-3	ETK-T2.2B, ETK-T2.2C: internal and external Memory	18
Fig. 4-4	Data Emulation and Measurement Data Memory: 2 Pages with 1024 kByte each 19	
Fig. 4-5	Division of the 256 Byte Trigger Segment	20
Fig. 4-6	Power Supply Connectors CON2 and CON3	23
Fig. 4-7	Power Supply Connector CON2	23
Fig. 4-8	Location of the Serial ETK Interface	24
Fig. 4-9	Location of the Debugger Interface	25
Fig. 4-10	Status LEDs	26
Fig. 4-11	Chip Select Configuration Bridge	27
Fig. 5-1	ETK-T2.2 Connection to the ECU	28
Fig. 5-2	ETK-T2.2 with Microcontroller mounted on ECU	28
Fig. 5-3	ETK-T2.2 Connection to the ECU and to the Debugger	29
Fig. 5-4	Permanent Power Supply inside ECU available	30
Fig. 5-5	Permanent Power Supply inside ECU not available	30
Fig. 5-6	Isolated Power Supply inside ECU	30
Fig. 7-1	Read Cycle: Data Emulation and Measurement Data DPR	40
Fig. 7-2	Write Cycle: Data Emulation and Measurement Data DPR	40
Fig. 7-3	Power Supply Connector CON2	41
Fig. 7-4	ETK-T2.2A and ETK-T2.2B Dimensions - Top View	41
Fig. 7-5	Microcontroller with Socket Adapter mounted (ETK-T2.2A and ETK-T2.2B)	42
Fig. 7-6	ETK-T2.2C Dimensions - Top View	43
Fig. 7-7	ETK-T2.2D Dimensions - Top View	44
Fig. 7-8	Microcontroller directly soldered (ETK-T2.2D).	44
Fig. 8-1	Interface Cable KA54, Proposal 1	45
Fig. 8-2	Interface Cable KA54, Proposal 2	46
Fig. 8-3	Interface Cable KA55	47
Fig. 8-4	Interface Cable CBAM200-0m38	47
Fig. 8-5	Power Supply Cable ETV	47
Fig. 8-6	Power Supply Cable with Filtercoil ETV2	48
Fig. 8-7	Power Supply Cable K70	48

Fig. 8-8	Power Supply Cable KA50 .....	48
Fig. 8-9	Power Supply Cable CBM200 .....	48
Fig. 8-10	Combined Interface and Power Supply Cable CBAM210 .....	49
Fig. 8-11	Combined Interface and Power Supply Cable CBAM220 .....	49
Fig. 8-12	ETAF5 - Mechanical Dimensions and Component Placement .....	50
Fig. 8-13	ETAF5 Flatcable .....	50
Fig. 8-14	ETAF9 Component Placement .....	51
Fig. 8-15	ETAF9 - Mechanical Dimensions and Component Placement .....	51
Fig. 8-16	ETAF9 Flatcable .....	51

# Index

---

- A**  
Adapters .....50  
Applications .....14  
Architecture .....16
- B**  
BGA Connector .....17  
Block diagram .....16  
Braindead Flash ..... 21, 37, 39
- C**  
Cable  
    Comb. Interface and Power Supply 49  
    Interface .....45  
    Power Supply .....47  
Code  
    Flash Memory .....21  
Code Flash Memory .....21  
Comb. Interface and Power Supply Cables  
    .....49  
Configuration .....35  
Configuration Parameter .....32
- D**  
Data .....21  
Data Emulation Memory .....19  
Data Flash Memory .....21  
Data Retention .....21  
Deactivation .....22  
Debug Adapter .....53  
Debug Interface .....25  
Documentation .....8
- E**  
ECU/ETK Sockets and Adapters .....53  
Electrical Characteristics .....37  
Emulation Memory .....35  
Environmental Conditions .....35  
ETAF5 Flatcable .....50  
ETAF5 PCB .....50  
ETAF9 Flatcable .....51  
ETAF9 PCB .....51  
ETAS Hardware .....34  
ETK Configuration .....31  
ETK Configuration Tool .....31  
ETKT2.0 Deactivation .....21  
ETK-T2.1 Versions ..... 16, 34
- F**  
Features .....15  
Flash Memory .....35
- I**  
Identifications on the product .....11  
Interface  
    ETK .....24  
    Processor .....17  
    Serial .....24  
Interface Cables ..... 45, 54  
Introduction .....14  
Isolated Power Supply .....30
- L**  
LED .....26
- M**  
Measured Memory .....35  
Measurement Data  
    Capture .....20  
Measurement Data Memory .....19  
Mechanical Dimension .....41  
Memory .....35  
    Code .....21  
Microcontroller Bus Interface .....36  
Microcontroller Support .....34
- O**  
Ordering Information .....52
- P**  
Power Supply .....23, 30, 55  
Power Supply Cables .....54  
Power Supply Connector ..... 23, 41  
Processor Interface .....17  
Product  
    Exclusion of liability .....8  
Product Back .....12  
Program Code .....21
- R**  
REACH regulation (EU) .....13  
Read Timing .....40  
Recycling .....12  
Reset .....22  
RoHS conformity  
    China .....13  
    European Union .....13
- S**  
Safety precautions .....8  
Serial ETK Interface ..... 24, 35  
Software Support .....34  
Status LED .....26  
Switching Characteristic .....40  
System Requirements .....34
- T**  
Testcharacteristics .....36  
Timing  
    Read .....40  
    Write .....40  
Trigger Segment .....20  
Triggering .....20
- U**  
UKCA conformity .....12

Update .....35  
Use, intended .....8

**W**

Waste Electrical and Electronic Equipment  
.....12  
WEEE .....12  
WEEE take-back system .....12  
Write Timing .....40