

ETAN8 R01_EN

FETK-T3.0 ECU Adapter, SAMTEC ERM - SAMTEC ERM (40mc – 34mc), 0m150



Copyright

The data in this document may not be altered or amended without special notification from ETAS GmbH. ETAS GmbH undertakes no further obligation in relation to this document. The software described in it can only be used if the customer is in possession of a general license agreement or single license. Using and copying is only allowed in concurrence with the specifications stipulated in the contract.

Under no circumstances may any part of this document be copied, reproduced, transmitted, stored in a retrieval system or translated into another language without the express written permission of ETAS GmbH.

© Copyright 2019 ETAS GmbH, Stuttgart

The names and designations used in this document are trademarks or brands belonging to the respective owners.

Document ETAN8 R01_EN – 03.2019

Contents

- 1 Introduction.....5
 - 1.1 3D View.....5
- 2 Technical Data6
 - 2.1 Mezz Board (ECU) Connector6
 - 2.2 Electrical Information7
 - 2.3 Mechanical Dimensions.....8
 - 2.4 Temperature Range8
- 3 Ordering Information.....9
- 4 ETAS Contact Addresses10

Figures

Figure 1: 3D View 5

Figure 2: Pin arrangement..... 6

Figure 3: Top View, Units inches [mm]..... 8

Figure 4: Side View, Units inches [mm]..... 8

1 Introduction

The ETAN8A cable adapts the ECU 34 pin SAMTEC ASP-137973-01 connector (34 pin Nexus Standard) to an FETK-T3.0. On the end that mates with the FETK, there is a single mounting hole that aligns with one of the FETK-T3 mounting holes for enhanced mechanical attachment. On the end that mates with the Renesas Mezz board, there are holes that align with the holes in the Renesas Mezz board (Renesas Part number Y-RH850-E2EVA2-468-MEZZ-V1).

1.1 3D View

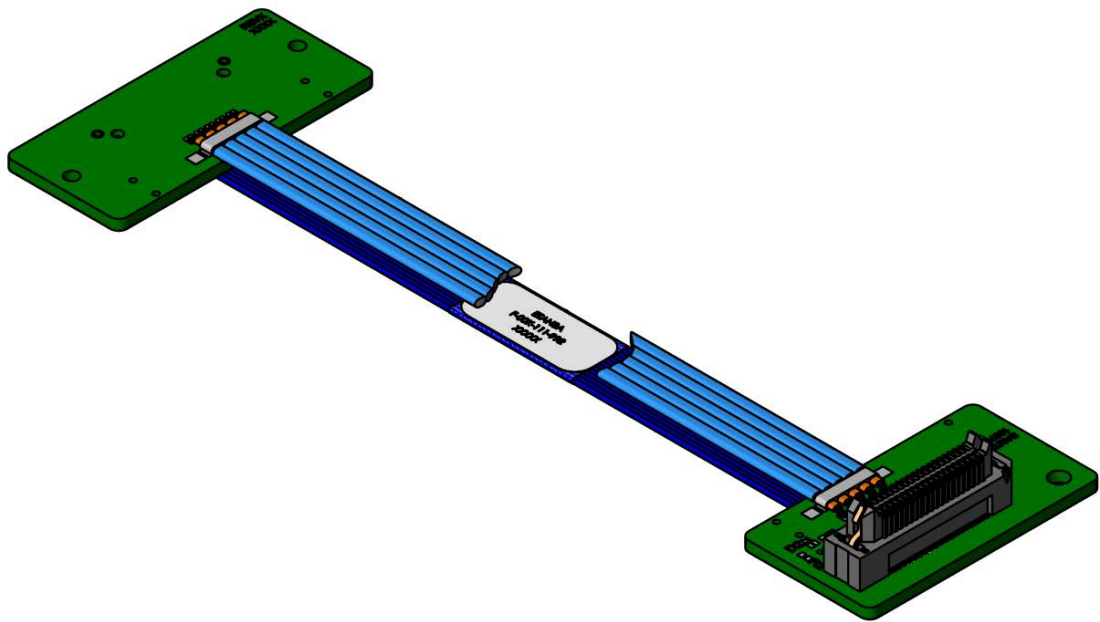

Figure 1: 3D View

2 Technical Data

2.1 Mezz Board (ECU) Connector

In order to be able to use the ETK adapter cable ETAN8A in the ECU, a 34 pin SAMTEC connector (e.g. ASP-137973-01) must be available on the Mezz Board or ECU. See figure 2 below for pin arrangement, and table 1 below for the pin assignment.

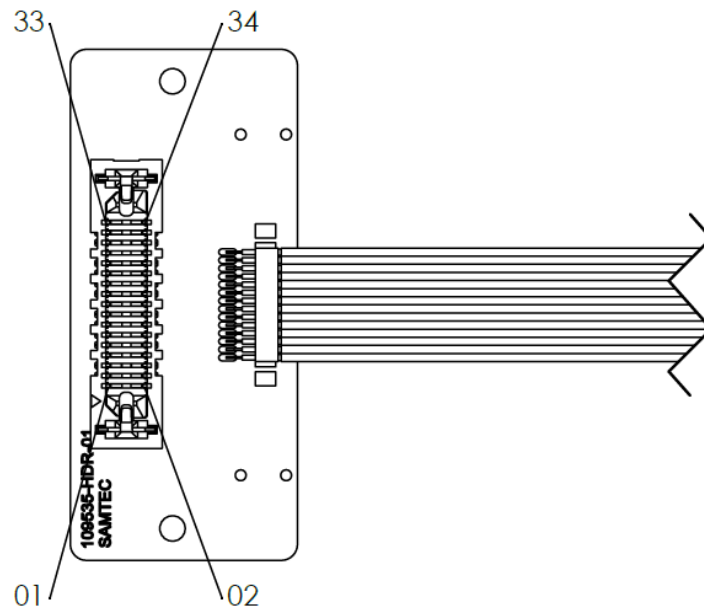

Figure 2: Pin arrangement

Pin Number	Signal Name
1	TX0_P
2	VDD (Sense)
3	TX0_N
4	TCK
5	GND
6	TMS
7	TX1_P
8	TDI
9	TX1_N
10	TDO
11	GND
12	/TRST

Pin Number	Signal Name
13	TX2_P
14	FLMD0
15	TX2_N
16	N/C
17	GND
18	/EVTO
19	TX3_P
20	N/C
21	TX3_N
22	/PORESET
23	GND
24	GND
25	N/C
26	ClockP
27	WDGDIS
28	ClockN
29	GND
30	GND
31	AURORA_RST
32	/RDY
33	VSTBY (Sense)
34	/RESETOUT

Table 1: Pin assignment

2.2 Electrical Information

The ETAN8A adapter cable has a 50 Ohm nominal impedance on pins 2, 4, 6, 8, 10, 12, 14, 18, 22, 27, 31, 32, 33, and 34. The ETAN8A adapter cable has a 100 Ohm nominal impedance for the differential signals on pins 1, 3, 7, 9, 13, 15, 19, 21, 26, and 28.

2.3 Mechanical Dimensions

The ETAN8A adapter cable has a minimum bend radius of 0.125 inches [3.175mm]. See figure 3 and 4 for mechanical dimensions.

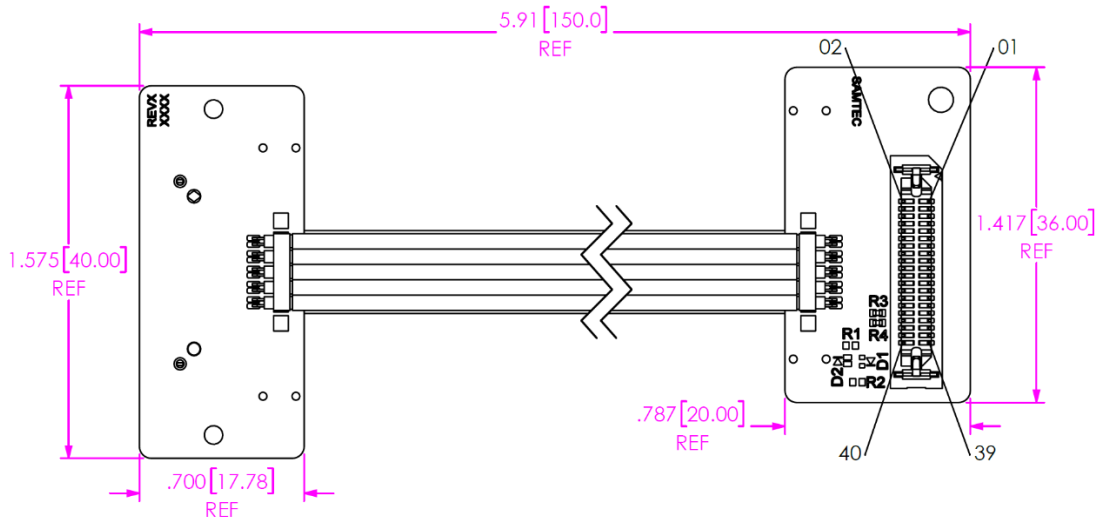

Figure 3: Top View, Units inches [mm]

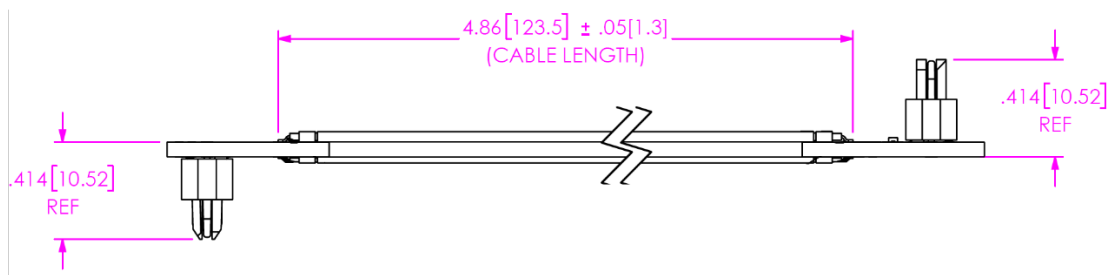

Figure 4: Side View, Units inches [mm]

2.4 Temperature Range

Condition	Temperature
Operating Temperature	-40°C - +110°C

3 **Ordering Information**

Short Name	Order - Number
ETAN8A	F 00K 111 992

4 **ETAS Contact Addresses**

ETAS HQ

ETAS GmbH	Phone:	+49 711 3423-0
Borsigstraße 24	Fax:	+49 711 3423-106
70469 Stuttgart	WWW:	www.etas.com
Germany		

ETAS Subsidiaries and Technical Support

For details of your local sales office as well as your local technical support team and product hotlines, take a look at the ETAS website:

ETAS subsidiaries	WWW:	www.etas.com/en/contact.php
ETAS technical support	WWW:	www.etas.com/en/hotlines.php