

CBEB105.1-1m0
Media Converter
User's Guide



Copyright

The data in this document may not be altered or amended without special notification from ETAS GmbH. ETAS GmbH undertakes no further obligation in relation to this document. The software described in it can only be used if the customer is in possession of a general license agreement or single license. Using and copying is only allowed in concurrence with the specifications stipulated in the contract.

Under no circumstances may any part of this document be copied, reproduced, transmitted, stored in a retrieval system or translated into another language without the express written permission of ETAS GmbH.

© **Copyright 2016** ETAS GmbH, Stuttgart

The names and designations used in this document are trademarks or brands belonging to the respective owners.

CBE105.1-1m0 - User's Guide R02 EN - 06.2016

Contents

1	About this Manual	5
1.1	Identification of Safety Notices	5
1.2	Presentation of Information	6
1.3	Scope of Supply	6
2	Basic Safety Notices	7
2.1	General Safety Information	7
2.2	Requirements for Users and Duties for Operators	7
2.3	Intended use	7
3	Hardware description	11
3.1	Overview	11
3.1.1	Description	11
3.1.2	Properties	11
3.2	Design	12
3.2.1	Housing	12
3.2.2	Connections	12
3.2.3	LEDs	13
3.3	Functions	14
3.3.1	Block diagram	14
3.3.2	Standby	14
3.3.3	Master-slave configuration	14
4	Startup	15
4.1	Cabling	15
4.2	Cabling example	16
5	Technical Data	17
5.1	General Data	17
5.1.1	Product labeling	17

5.1.2	Standards and Norms	18
5.1.3	Environmental Conditions	18
5.1.4	Cleaning the product.	18
5.1.5	Mechanical Data	18
5.2	RoHS conformity	19
5.2.1	European Union	19
5.2.2	China	19
5.3	CE marking	19
5.4	Product return and recycling	19
5.5	Use of Open Source Software	20
5.6	System Requirements	20
5.7	Pin Assignment	20
5.7.1	D-SUB9-Plug	20
5.7.2	LEMO-Plug	21
5.8	Electrical Data	21
6	Ordering Information	23
7	ETAS Contact Addresses	25
	Figures	27
	Index	29

1 **About this Manual**

This chapter contains information about the following topics:

- "Identification of Safety Notices" on page 5
- "Presentation of Information" on page 6
- "Scope of Supply" on page 6

1.1 **Identification of Safety Notices**

The safety notices contained in this manual are identified with the danger symbol shown below:



The safety notices shown below are used for this purpose. They provide notes to extremely important information. Please read this information carefully.



DANGER!

indicates an immediate danger with a high risk of death or serious injury, if not avoided.



WARNING!

indicates a possible danger with moderate risk of death or (serious) injury, if not avoided.



CAUTION!

identifies a hazard with low risk that could result in minor or medium physical injuries or property damages if not avoided.

1.2 Presentation of Information

All activities to be performed by the user are presented in a "Use Case" format. That is, the goal to be accomplished is briefly defined in the heading, and the respective steps required for reaching this goal are then presented in a list. The presentation looks as follows:

Goal definition:

any advance information...

- Step 1
Any explanation for step 1...
- Step 2
Any explanation for step 2...
- Step 3
Any explanation for step 3...

Any concluding comments...

Typographical conventions

The following typographical conventions are used:

Bold	Labels of the device
<i>Italic</i>	Particularly important text passages

Important notes for the user are presented as follows:

Note

Important note for the user.

1.3 Scope of Supply

Prior to the initial commissioning of the module, please check whether the module was delivered with all required components and cables (see chapter "Ordering Information" on page 23).

Additional cables and adapters can be obtained separately from ETAS. A list of available accessories and their order designation is located in chapter "Ordering Information" on page 23 of this manual or in the ETAS product catalog.

2 Basic Safety Notices

This chapter contains information about the following topics:

- "General Safety Information" on page 7
- "Requirements for Users and Duties for Operators" on page 7
- "Intended use" on page 7.

2.1 General Safety Information

Please observe the Product Safety Notices ("ETAS Safety Notice") and the following safety notices to avoid health issues or damage to the device.

Note

Carefully read the documentation (Product Safety Advice and this User's Guide) that belongs to the product prior to the startup.

ETAS GmbH does not assume any liability for damages resulting from improper handling, unintended use or non-observance of the safety precautions.

2.2 Requirements for Users and Duties for Operators

The product may be assembled, operated and maintained only if you have the necessary qualification and experience for this product. Improper use or use by users without sufficient qualification can lead to damages or injuries to one's health or damages to property.

The safety of systems that are using the product is the responsibility of the system integrator.

General safety at work

The existing regulations about safety at work and accident prevention must be followed. All applicable regulations and statutes regarding operation must be strictly followed when using this product.

2.3 Intended use

Application area of the product

This product was developed and approved for applications in the automotive sector. The product is designed for use in the interior, in the passenger cells or in the trunk of vehicles.

For use in other application areas, please contact your ETAS contact partner.

Requirements for the technical state of the product

The product is designed in accordance with state-of-the-art technology and recognized safety rules. The product may be operated only in a technically flawless condition and according to the intended purpose and with regard to safety and dangers as stated in the respective product documentation. If the product is not used according to its intended purpose, the protection of the product may be impaired.

Requirements for operation

- Use the product only according to the specifications in the corresponding User's Guide. In case of any deviating use, the product safety is not ensured.
- Observe the requirements on the ambient conditions.
- Do not use the product in potentially explosive atmospheres.

Electrical safety and power supply

- Observe the applicable regulations as well as the statutes and regulations on safety at work at the location site!
- Connect only current circuits with safety extra-low voltage in accordance with EN 61140 (degree of protection III) to the connections of the product.
- Ensure that the connection and setting values are being followed (see the information in the chapter "Technical Data").
- Do not apply any voltages to the connections of the product that do not correspond to the specifications of the respective connection.

Power supply

- The power supply for the product must be safely disconnected from the supply voltage. For example, use a car battery or a suitable lab power supply.
- Use only lab power supplies with double protection to the supply network (with double / reinforced insulation (DI/ RI)).
- The lab power supply must be designed for an operating altitude of 5,000 m and for an ambient temperature of up to 70 °C.
- For regular operation of the products as well as for very long standby operation, it is possible that the vehicle battery will be depleted.

Connection to the power supply

- Use the media converter only in vehicles with central load dump protection.
- The power supply cable may not be connected directly to the vehicle battery or the lab power supply but, instead, via a suitable fuse.
- Ensure that the connectors of the lab power supply, the power supply at the product and the vehicle battery are easily accessible!
- Route the power cord in such a way that it is protected against abrasion, damages, deformation and kinking.
- Do not place any objects on the power cord!

**DANGER!*****Dangerous electrical voltage!***

Connect the power cable only with a suitable vehicle battery or with a suitable lab power supply! The connection to power outlets is not allowed!

To prevent an inadvertent insertion in power outlets, ETAS recommends to equip the power cables with safety banana plugs in areas with power outlets.

De-energizing the product

The CBEB105.1-1m0 does not feature an operating voltage switch. The product can be de-energized as follows:

- Disconnect the LEMO plug of the media converter from the module
or
- De-energize the module connected to the LEMO plug.

Cabling

Approved cables:

- Use exclusively ETAS cables at the connections of the product!
- Adhere to the maximum permissible cable lengths!
- Do not use any damaged cables! Cables may be repaired only by ETAS!



CAUTION!

Never apply force to insert a plug into a socket.

Ensure that there is no contamination in and on the connection, that the plug fits the socket, and that you correctly aligned the plugs with the connection.

For detailed information about cabling, see the User's Guide of the module.



CAUTION!

Potential equalization in the vehicle is possible via the shield of the connecting cables of the modules!

Install the products only at locations with the same electrical potential or isolate the products from the installation location.

Requirements for the place of installation

- Place the product on a smooth, even and solid ground.
- Securely fasten the product.

Requirements on the ventilation

- Keep the product away from heat sources and protect it against direct exposure to the sun.
- The free space above and behind the product must be selected so that sufficient air circulation is ensured.

Damage of the product and loss of properties in accordance with IP40



CAUTION!

Loss of Properties in accordance with IP40!

Do not open or modify the product housing!

Work on the product housing may be performed only by qualified technical personnel.

Transport

- Do not transport the product using the cable of the product or any other cable.
- Prior to the transport, disconnect the cables from the product.

Maintenance

The product is maintenance-free.

Repair

If an ETAS hardware product should require a repair, return the product to ETAS.

Cleaning the module housing

- Use a dry or lightly moistened, soft, lint-free cloth for cleaning the module housing.
- Do not use any sprays, solvents or abrasive cleaners which could damage the housing.
- Ensure that no moisture enters the housing. Never spray cleaning agents directly onto the product.

3 Hardware description

This chapter contains information about the following topics:

- "Overview" on page 11
- "Design" on page 12
- "Functions" on page 14

3.1 Overview

3.1.1 Description



Fig. 3-1 Media Converter CBEB105.1-1m0

The Media Converter CBEB105.1-1m0 converts automotive Ethernet to standard Ethernet (IEEE802.3). It connects ETKs with automotive Ethernet interface (BR_XETK) and modules with integrated standard Ethernet interface.

3.1.2 Properties

The most important properties of the CBEB105.1-1m0 Media Converter:

- Converting automotive Ethernet to standard Ethernet (IEEE802.3)
- Automotive-capable product that is suitable for use in the development environment and in the vehicle on test courses.
 - Immune to ambient conditions (temperature, EMC)
 - Wide supply voltage range
 - High level of mechanical stability and robustness
- Display of operating status and error states
- D-SUB9 plug for connecting the product
- Standby operation
- Master operation
- Configurable for slave operation
- No additional drivers required
- Together with BR_XETKs, the product supports the measurement, application and flash programming.

Complete technical data for the Media Converter can be found in the chapter "Technical Data" on page 17.

3.2 Design

3.2.1 Housing

The housing consists of a colored thermoplastic elastomer with rubber design. The housing, plugs and plug connectors of the cables meet degree of protection IP40.



CAUTION!

Loss of Properties in accordance with IP40!

Do not open or modify the product housing!

Work on the product housing may be performed only by qualified technical personnel.

3.2.2 Connections







Fig. 3-2 CBE105.1-1m0 Connections

No. in Fig. 3-2	Connection	Protocol
1	D-SUB9	Automotive Ethernet
2	LEMO 1B	Standard Ethernet



3.2.3 LEDs

The CBEB105.1-1m0 Media Converter features 3 LEDs. They indicate the following states:

ON ER - power supply / operating status

LED code	Display	State
ON OFF 	Off	No power supply
ON  OFF	Green illuminated	Operational
ON  OFF	Flashing green (0.1 s on / 1.9 s off)	Standby
ON  OFF	Flashing green (0.5 s on / 0.5 s reduced)	Slave
ON  OFF	Flashing red	Boot error - restart required: Disconnect the LEMO plug from the module for 5 s. <hr/> Hardware error: If the LED continues to permanently flash even after a reboot, send the product to ETAS.

HOST - Standard Ethernet

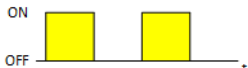
LED code	Display	State
ON OFF 	Off	Link inactive
ON  OFF	Yellow illuminated	Link active
ON  OFF	Flashing yellow acc. to network activity	Network activity

ECU - Automotive Ethernet

LED code	Display	State
ON OFF _____ t	Off	Link inactive
ON OFF _____ t	Yellow illuminated	Link active
ON OFF _____ t	Flashing yellow acc. to network activity	Network activity

3.3 Functions

3.3.1 Block diagram

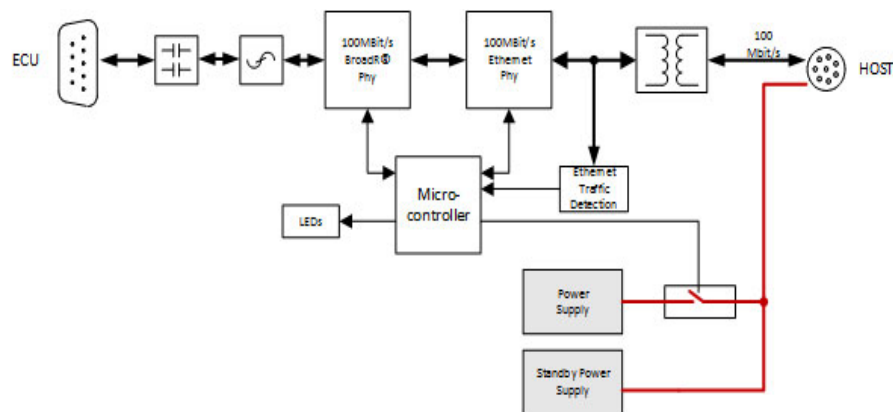

Fig. 3-3 Block diagram

The CBE105.1-1m0 Media Converter features an automotive Ethernet interface at the D-SUB9 plug as well as a standard Ethernet interface (IEEE 802.3) at the LEMO plug.

3.3.2 Standby

If a BR_XETK is connected to the Media Converter, the product checks a connection on the HOST side. If the product does not detect a connection within 5 minutes, it switches to standby mode.

3.3.3 Master-slave configuration

The product is configured as master by default. For configuration as slave, please contact your ETAS contact partner.

4 Startup

This chapter contains information about the following topics:

- "Cabling" on page 15
- "Cabling example" on page 16

4.1 Cabling

The CBEB105.1-1m0 can be integrated into the measuring setup without any problems and without first having to de-energize other modules. The following steps describe the startup in a an energized cabling system:

Startup of CBEB105.1-1m0

1. Connect the LEMO plug of the Media Converter with the module.
The **ON ER** LED lights green.
The **HOST** LED signals network activity.
2. Connect the D-SUB9 plugs of the Media Converter with the ECU with integrated BR_XETK.
The **ECU** LED signals network activity.

4.2 Cabling example

Connection of Media Converter to BR_XETK via ES600

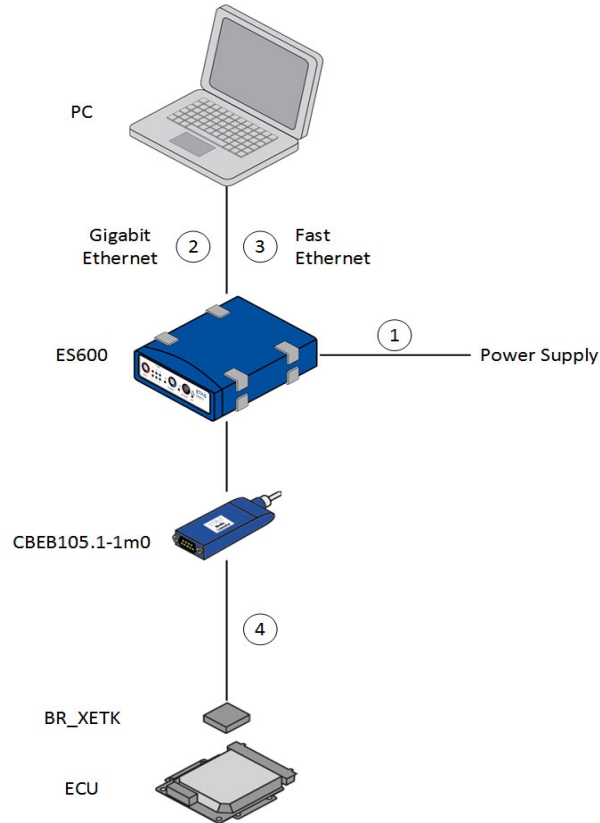

Fig. 4-1 Connection of Media Converter to BR_XETK via ES600

Cables in Fig. 4-1	Function	Short name
1	Cable for the "7-29 V DC " connection	CBP120, CBP1205
2	Cable for the "GE-HOST" connection	CBE100
3	Cable for the "FE-HOST" connection	CBE130, CBE140
4	Cable for the connection "ECU with BR_XETK" (customer-specific - Please contact your ETAS contact partner.)	

5 Technical Data



This chapter contains information on the following topics:

- "General Data" on page 17
- "RoHS conformity" on page 19
- "CE marking" on page 19
- "Product return and recycling" on page 19
- "System Requirements" on page 20
- "Pin Assignment" on page 20.
- "Electrical Data" on page 21

5.1 General Data

5.1.1 Product labeling

The following symbols are used for product labeling:

Symbol	Beschreibung
	Prior to operating the product, be sure to read the user's guide!
1: NC	
2: NC	
3: Shielding	
4: BroadR-Reach(R)(+)	
5: BroadR-Reach(R)(-)	
6: NC	
7: Reserved	
8: Reserved	
9: NC	
SN: 123456	Serial number (seven-digit)
F 00K 110 321	Ordering number of the product, see chapter "Ordering Information" on page 23
6-32 V DC	Operating voltage
200 mA	Power consumption
	Labeling for CE conformity, see chapter "CE marking" on page 19
	Labeling for WEEE, see chapter "Product return and recycling" on page 19

5.1.2 Standards and Norms

The Media Converter CBEB105.1-1m0 adheres to the following standards and norms:

Norm	Prüfung
IEC 61010-1	
IEC 61326-1	

5.1.3 Environmental Conditions

Operating temperature range	-40 °C to +70 °C -40 °F to +158 °F
Storage temperature range (module without packaging)	-40 °C to +85 °C -40 °F to +285 °F
Altitude	max. 5000 m / 16400 ft
Protection class	IP40
Humidity	15 % to 95 %, noncondensing

5.1.4 Cleaning the product

We recommend to clean the product with a dry cloth.

5.1.5 Mechanical Data

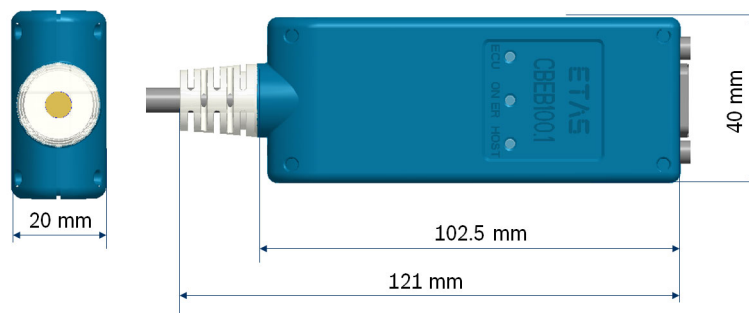

Fig. 5-1 Dimensions

Dimensions (H x W x D)	40 mm x 20 mm x 102.5 mm 1.57 in x 0.79 in x 4.04 in
Length (Housing with cable)	1102.5 mm / 4.04 in
Weight (Housing with cable)	115 g / 0.25lb

5.2 RoHS conformity

5.2.1 European Union

The EU Directive 2011/65/EU limits the use of certain dangerous materials for electric and electronic devices (RoHS conformity).

ETAS confirms that the product meets this directive applicable in the European Union.

5.2.2 China

ETAS confirms that the product meets the "China RoHS" (Management Methods for Controlling Pollution Caused by Electronic Information Products Regulation) guidelines applicable to the People's Republic of China with a China RoHS label attached to the product or its packaging.

5.3 CE marking

With the CE mark attached to the product or its packaging, ETAS confirms that the product corresponds to the product-specific, applicable European Directives. The CE Declaration of Conformity for the product is available upon request.

5.4 Product return and recycling

The European Union (EU) has issued the guideline on waste electric and electronic equipment (Waste Electrical and Electronic Equipment - WEEE) in order to ensure the institution of systems for collection, handling, and disposal of all electronic scrap.

This ensures that the devices are recycled in a resource-friendly way that does not represent any risk to personal health and the environment.



Fig. 5-2 WEEE symbol

The WEEE symbol (see Fig. 5-2 on page 19) on the product or its packaging identifies that the product may not be disposed of together with the remaining trash.

The user is obligated to separate the waste equipment and to provide it to the WEEE return system for reuse.

The WEEE Directive applies to all ETAS devices, but not to external cables or batteries.

Additional information about the recycling program of ETAS GmbH is available from the ETAS sales and service locations (see chapter 7 on page 25).

5.5 Use of Open Source Software

The product uses Open Source Software (OSS). This software is installed in the product at the time of delivery and does not have to be installed or updated by the user. Reference shall be made to the use of the software in order to fulfill OSS licensing terms. Additional information is available in the document "OSS Attributions List" at the ETAS website www.etas.com.

5.6 System Requirements

The CBEB105.1-1m0 can be connected to modules with a Fast-Ethernet-interface, e.g.:

- ES600
- ES592, ES593, ES595
- ES720

5.7 Pin Assignment

5.7.1 D-SUB9-Plug

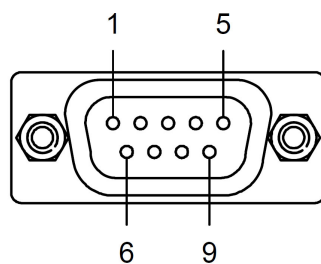

Fig. 5-3 Pin assignment D-SUB9-Plug

Pin	Signal	Meaning
1	NC	not connected
2	NC	not connected
3	Schirmung	Shielding
4	BroadR-Reach (+)	BroadR-Reach Plus
5	BroadR-Reach (-)	BroadR-Reach Minus
6	NC	not connected
7	reserviert	reserved
8	reserviert	reserved
9	NC	not connected

5.7.2 LEMO-Plug

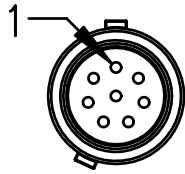

Fig. 5-4 Pin assignment LEMO-Plug

Pin	Signal	Beschreibung
1	UBATT +	Supply voltage, positive
2	UBATT +	Supply voltage, positive
3	UBATT -	Supply voltage, negative
4	TX+	send data, positive
5	RX-	receive, negative
6	TX-	send data, negative
7	NC	not conneted
8	RX+	receive data, positive

5.8 Electrical Data

Operating voltage	6 V to 32 V DC
Valid cranking voltage	<3 sec. to min. 3 V DC
Overvoltage 60 minutes	36 V DC
Current consumption	max. 200 mA
Current consumption (operation)	typ. 85 mA at 12 V DC
Current consumption (standby)	typ. 5.5 mA at 12 V DC
Protection	against reverse polarity

6 **Ordering Information**

Order name	Short name	Order number
Media Converter Cable, D-SUB - LEMO (9mc-8mc), 1m	CBEB105.1-1m0	F-00K-110-321

Package Contents

CBEB105.1-1m0 Media Converter
List "Content of this Package"
ETAS Safety Advice CBEB100
China_RoHS-leaflet_Compact_green_cn

7 **ETAS Contact Addresses**

ETAS HQ

ETAS GmbH

Borsigstraße 14

70469 Stuttgart

Germany

Phone: +49 711 3423-0

Fax: +49 711 3423-2106

WWW: www.etas.com

ETAS Subsidiaries and Technical Support

For details of your local sales office as well as your local technical support team and product hotlines, take a look at the ETAS website:

ETAS subsidiaries WWW: www.etas.com/en/contact.php

ETAS technical support WWW: www.etas.com/en/hotlines.php

Figures

Fig. 3-1	Media Converter CBEB105.1-1m0	11
Fig. 3-2	CBEB105.1-1m0 Connections.....	12
Fig. 3-3	Block diagram.....	14
Fig. 4-1	Connection of Media Converter to BR_XETK via ES600.....	16
Fig. 5-1	Dimensions.....	18
Fig. 5-2	WEEE symbol.....	19
Fig. 5-3	Pin assignment D-SUB9-Plug.....	20
Fig. 5-4	Pin assignment LEMO-Plug	21

Index

A

Accident prevention 7

B

Block diagram 14

C

Cabling 15

Cabling example 16

CE Declaration of Conformity 19

Connections 12

D

Data

 electrical 21

 mechanical 18

E

Environmental Conditions 18

ETAS Contact Addresses 25

F

Functions 14

G

General Data 17

H

Hardware

 system requirements 21

Housing 12

L

LEDs 13

M

Master configuration 14

N

Norms 18

O

Operation

 Conventions 6

 Use Case 6

Ordering Information 23

P

Presentation of information 6

Product

 Exclusion of liability 7

Product return 19

Properties 11

Q

Qualification, required 7

R

Recycling 19

RoHS conformity

 China 19

 European Union 19

S

Safety at work 7

Safety notices

 basic 7

 Identification 5

Safety precautions 7

Scope of supply 6

Slave configuration 14

Standards 18

Standby 14

Startup 15

System requirements 20

U

Use, intended 7

W

Waste Electrical and Electronic Equipment
- WEEE 19