



ES5372.1-B 1

Slot Carrier Board for ES4455.2 and ES4456.2

User's Guide

Copyright

The data in this document may not be altered or amended without special notification from ETAS GmbH. ETAS GmbH undertakes no further obligation in relation to this document. The software described in it can only be used if the customer is in possession of a general license agreement or single license. Using and copying is only allowed in concurrence with the specifications stipulated in the contract.

Under no circumstances may any part of this document be copied, reproduced, transmitted, stored in a retrieval system or translated into another language without the express written permission of ETAS GmbH.

© **Copyright 2020** ETAS GmbH, Stuttgart

The names and designations used in this document are trademarks or brands belonging to the respective owners.

ES5372.1-B 1 Slot Carrier Board for ES4455.2 and ES4456.2 - User's Guide
V1.0.0 R06 EN - 11.2023

Contents

1	Introduction	4
1.1	Properties	4
1.1.1	Properties of the ES5372.1-B	4
1.1.2	ES5372.1-B Block Diagram with ES4455.2	5
1.1.3	ES5372.1-B Block Diagram with ES4456.2	6
1.2	Basic Safety Notices	7
1.2.1	Identification of Safety Notices	7
1.2.2	General Safety Information	7
1.2.3	Requirements for Users and Duties for Operators	8
1.2.4	Intended Use	8
1.3	Identifications on the Product	14
1.3.1	CE Mark	14
1.3.2	RoHS Conformity	14
1.3.3	P007 Identification in Accordance with ISO 7010:2011	15
1.4	Product Return and Recycling	15
1.5	Materials Subject to Declaration	15
1.6	About this Manual	16
1.6.1	Working with this Manual	16
2	Setup, Installation and Fuses	18
2.1	Position of Plug Connections	20
2.2	Fuses	20
2.3	Installing the ES4456.2 in an ES5372.1-B	21
2.4	Installing the ES4455.2 in an ES5372.1-B	22
2.5	Installation / Removal of the ES5300.1-B into / from the ES5300.1-A Housing and ES5300.1-B Housing	24
3	Connections and Plug Connections	27
3.1	Backplane Connector CO402	27
3.2	Plug Connector X1	29
3.2.1	Technical Details of Plug Connector X1	30
3.3	Plug Connector X2 Load 0..7 on the Front Plate for Installed ES4456.2	32
3.4	Plug Connector CO201 for ES4455.2 or ES4456.2	33
4	Technical Data and Standards	36
4.1	Technical Data	36
4.2	Standards Met	37
5	Ordering Data	38
6	ETAS Contact Addresses	39
	Index	40

1 Introduction

This user's guide contains the description of the ES5372.1-B 1 Slot Carrier Board for ES4455.2 and ES4456.2. The ES5372.1-B is an adapter card that allows operating the ES4455.2 Load Carrier Board and the ES4456.2 Load Board for 8 RB CRI3-x Piezo Injectors in the ES5300.1-A Housing and in the ES5300.1-B Housing. The ES5372.1-B, fitted with the ES4455.2, can be used for connecting external loads, e.g. injectors. If the ES5372.1-B is fitted with the ES4456.2, it can also be used to simulate eight piezo injectors.

Since the ES5372.1-B occupies only one slot in the ES5300.1-A Housing or in the ES5300.1-B Housing, it is a space-saving alternative compared to the ES5372.1 if external loads are to be connected.

This chapter contains information about the following topics:

- "Properties" on page 4
- "Basic Safety Notices" on page 7
- "Identifications on the Product" on page 14
- "CE Mark" on page 14
- "RoHS Conformity" on page 14
- "Product Return and Recycling" on page 15
- "Materials Subject to Declaration" on page 15
- "About this Manual" on page 16

1.1 Properties

The chapter describes the fundamental properties of the ES5372.1-B.

1.1.1 Properties of the ES5372.1-B

The ES5372.1-B is a plug-in card for a LABCAR HiL system to be used in the ES5300.1-A Housing and in the ES5300.1-B Housing. The ES5372.1-B may be fitted with the ES4455.2 or the ES4456.2.

The properties of the ES5372.1-B are as follows:

- Plug-in card for a LABCAR HiL system
- Compatibility with the ES5300.1-A Housing and ES5300.1-B Housing
- Slot for an ES4455.2 or an ES4456.2 plug-in card
- 1 slot width for fitting a ES4455.2
- 3 slot width for fitting a ES4456.2
- Calibration of four external loads in a state fitted with the ES4455.2
- Simulation of eight piezo injectors in a state fitted with the ES4456.2

For additional specific properties in the fitted state, please read the ES4455.2 user's guide or the ES4456.2 user's guide.

1.1.2 ES5372.1-B Block Diagram with ES4455.2

The block diagram in Fig. 1-1 on page 5 shows the ES5372.1-B, fitted with an ES4455.2.

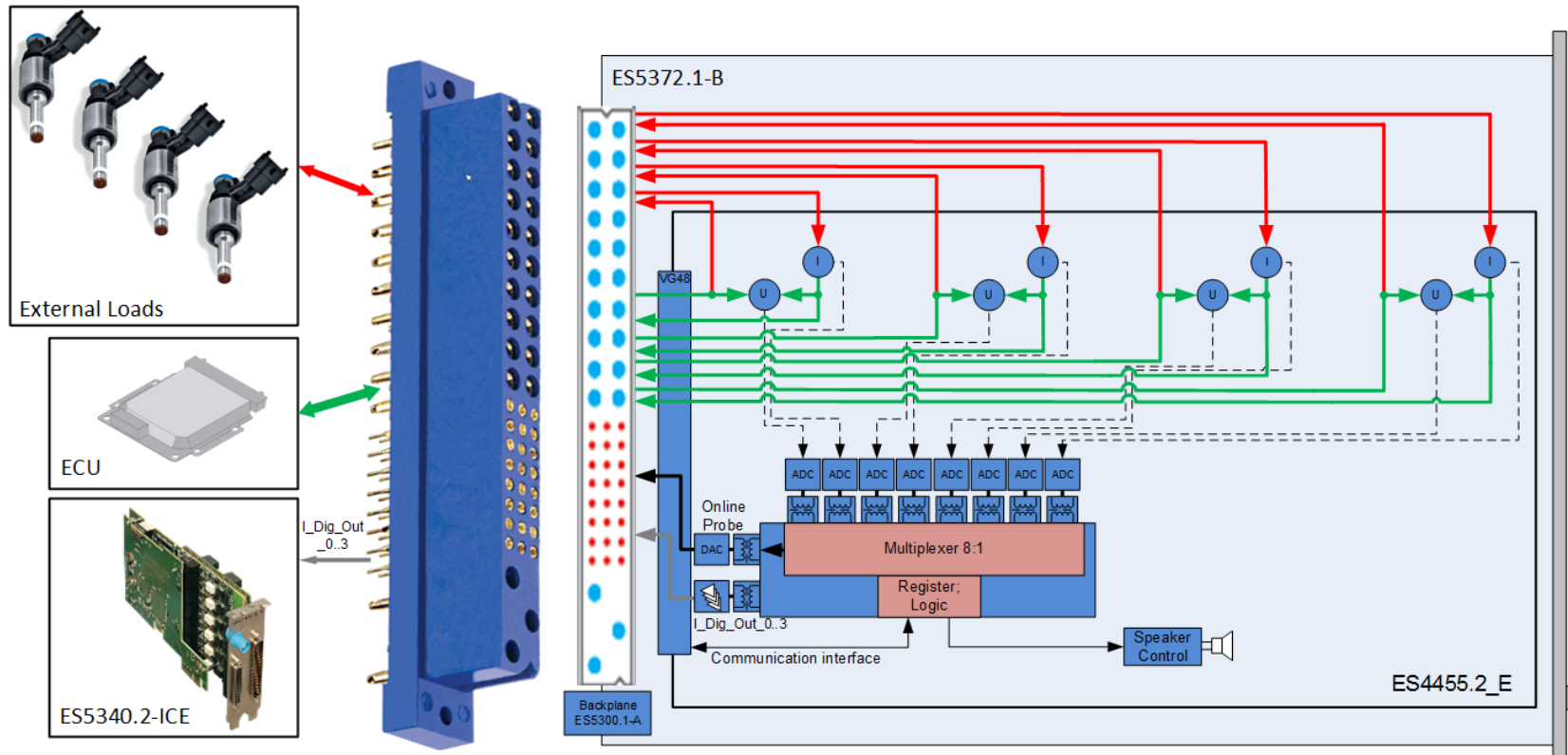

Fig. 1-1 Block diagram of ES5372.1-B, fitted with an ES4455.2

Fig. 1-2 shows an example for the use of the ES5372.1-Bs in an HiL system.

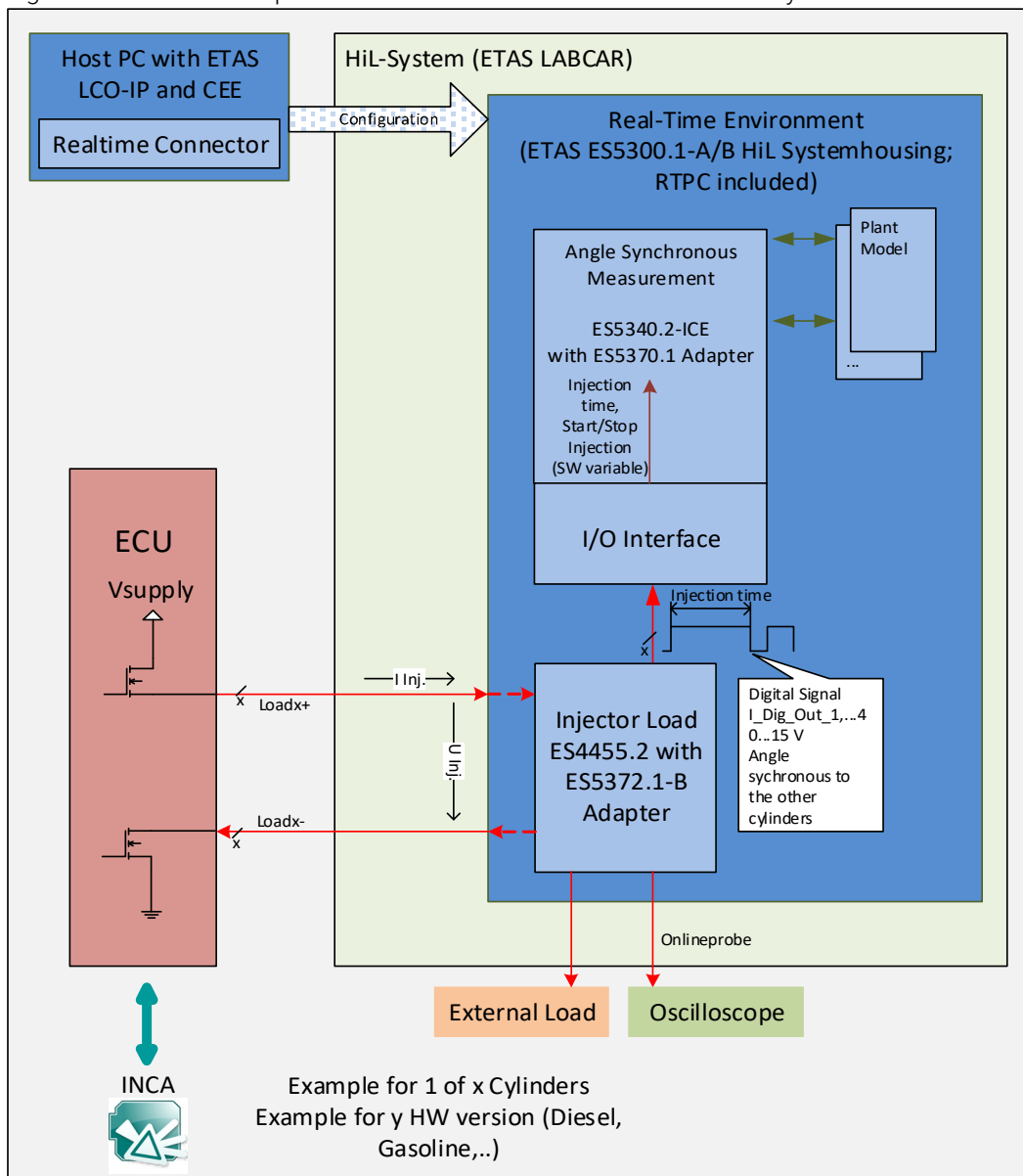

Fig. 1-2 Example for the integration of an ES5372.1-B in a LABCAR HiL system.

1.1.3 ES5372.1-B Block Diagram with ES4456.2

The block diagram for the ES4456.2 is located in the ES4456.2 user's guide.

1.2 Basic Safety Notices

Observe the following safety notices to avoid health issues or damage to the device.

1.2.1 Identification of Safety Notices

The safety notices contained in this manual are identified with the danger symbol shown below:



The safety notices shown below are used for this purpose. They provide notes to extremely important information. Read this information carefully.



CAUTION

identifies a hazard with low risk that could result in minor or medium physical injuries or property damages if not avoided.



WARNING

indicates a possible danger with moderate risk of death or (serious) injury, if not avoided.



DANGER

indicates an immediate danger with a high risk of death or serious injury, if not avoided.

1.2.2 General Safety Information

Observe the following safety notices to avoid health issues or damage to the device.



NOTE

The User's Guide and the Product Safety Advice must be read carefully prior to the startup of the product!

ETAS GmbH does not assume any liability for damages resulting from improper handling, unintended use or non-observance of the safety precautions.

1.2.3 Requirements for Users and Duties for Operators

The product may be assembled, operated and maintained only if you have the necessary qualification and experience for this product. Improper use or use by a user without sufficient qualification can lead to damages or injuries to one's health or damages to property.

The system integrator is responsible for the safety of systems that use the product.

General Safety at Work

Follow the existing regulations for work safety and accident prevention. All applicable regulations and laws regarding operation must be strictly adhered to when using this product.

1.2.4 Intended Use

The ES5372.1-B is a plug-in card for the ES5300.1-A Housing and the ES5300.1-B Housing. The ES5372.1-B is used for accepting an ES4455.2 or an ES4456.2 plug-in card.

The ES5372.1-B consists of the following:

- Slot for ES4455.2 or ES4456.2
- SPI interface to the ES5300.1-A Housing or ES5300.1-B Housing for configuring the cards
- Output interface to the ECU
- Digital interface for battery node control signals
- Voltage supply of the ES4455.2 or the ES4456.2
- Replacement load simulation for connecting to ECU output stages
- Interface for the battery voltage
(The simulation of the vehicle battery itself is not part of the ES5300.1-A Housing or ES5300.1-B Housing and cannot be installed here.)

The ES5372.1-B may be installed and operated only in the ES5300.1-A Housing or in the ES5300.1-B Housing.

The intended use of the ES5372.1-B in an ES5300.1-A Housing or ES5300.1-B Housing is:

- Use as a component in industrial lab facilities or at industrial workplaces
- Use as hardware interface for ECUs in a hardware-in-the-loop test system
- Use in conjunction with ETAS software that supports the ES5300.1-A Housing and the ES5300.1-B Housing
- Use as interface in cooperation with software programs that operate the standardized, documented and open APIs of ETAS software products

The ES5372.1-B is not intended for the following:

- Use within a vehicle on the road.
- Use as part of a life support system.
- Use as part of a medical application
- In applications where misuse can lead to injuries or damages.
- Use in environments in which conditions prevail that fall outside the specified ranges (see "Ambient Conditions" on page 37).
- Use with signal conditioning that falls outside the specified ranges (see voltages, currents and power consumption in the chapter "Technical Data" on page 36)

Requirements for the Technical State of the Product

The product is designed in accordance with state-of-the-art technology and recognized safety rules. The product may be operated only in a technically flawless condition and according to the intended purpose and with regard to safety and dangers as stated in the respective product documentation. If the product is not used according to its intended purpose, the protection of the product may be impaired.

Requirements for Operation

The following requirements are necessary for safe operation:

- Use the product only according to the specifications in the corresponding User's Guide. With any deviating operation, the product safety is no longer ensured.
- Do not use the product in a wet or damp environment.
- Do not use the product in potentially explosive atmospheres.

Electrical Safety and Power Supply

Observe the regulations applicable at the operating location concerning electrical safety as well as the laws and regulations concerning work safety!



DANGER

Risk of electric shock!

At the plug X2 Load 0...7 high voltages may still be present even after disconnecting the counter plug.

After disconnecting the cable, wait one minute before touching the connections or the circuit board. Parallel to the capacitors are resistors that allow a safe discharging.

Failure to do so poses a danger to life and health.

**WARNING****Danger of high voltages!**

The components, plug connectors, conductor paths of the ES5372.1-B and the installed ES4455.2 or ES4456.2 may have dangerous voltages. These voltages can also be present when the ES5372.1-B is not installed in the ES5300.1-A Housing or in the ES5300.1-B Housing or the ES5300.1-A Housing or if the ES5300.1-B Housing is switched off.

Ensure that the ES5372.1-B is protected against touching it during operation. Switch off the ES5300.1-A Housing or the ES5300.1-B Housing and pull the power plug. Wait at least three minutes before removing the ES5372.1-B.

**WARNING****Danger trough electromagnetic radiation!**

The ES5372.1-B, fitted with the ES4455.2 or the ES4456.2 and loads connected to it, can emit electromagnetic radiation during operation which can cause interference with the operation or damage pacemakers or implanted defibrillators.

The ES5372.1-B may be operated only in areas where persons with pacemakers are prohibited from entering. At the entrances to these areas, the P007 identification, "No access for persons with pacemakers or implanted defibrillators" in accordance with ISO 7010:2011 "Registered Safety Signs", must be attached and clearly legible.

Failure to observe it can lead to health hazards and even death for persons with pacemakers and implanted defibrillators.

**WARNING****Fire hazard!**

Use only fuses that meet the specification in Tab. 2-1 on page 21! Never bridge defective fuses!

Failure to observe the fuse specification can lead to excess currents, short circuits and fires.

Power Supply

The product is powered by the ES5300.1-A Housing or the ES5300.1-B Housing via the PCIe Backplane Connector.

Insulation Requirements for Lab Power Supplies to Circuits Connected to the HIL System:

- The power supply to live circuitry must be safely isolated from the supply voltage. For example, use a car battery or a suitable lab power supply.
- Only use lab power supplies with dual protection for the supply network (with double/reinforced insulation (DI/RI)). This requirement is met by lab power supplies that comply with IEC/EN 60950 or IEC/EN 61010.
- The lab power supply must be approved for use at a height of 2000 m and in ambient temperatures of up to 40 °C.

De-energizing a Plug-in Board

Switch off the ES5300.1-A Housing or the ES5300.1-B Housing and external power supplies, and unplug the power plug and other connectors attached to the plug-in board. Wait at least three minutes before removing the plug-in board.

Approved Cables

The signal lines must not exceed a maximum length of 3 m.



WARNING

Fire hazard!

Use only approved cables for creating cable assemblies (e.g. for connecting the ECU and external loads). The cables used must be suitable particularly for occurring currents, voltages and temperatures and flame-retardant in accordance with one of the following standards IEC 60332-1-2, IEC 60332-2-2, UL 2556/UL1581VW-1!

Requirements for the Installation Location



WARNING

This is class A equipment. This equipment can cause radio interference in residential areas. Should that be the case, the operator may be requested to institute reasonable measures.

Requirements for Ventilation



CAUTION

The air circulation inside the ES5300.1-A housing and the ES5300.1-B housing can be ensured only if all free slots are covered with front plates. Otherwise, it may lead to overtemperatures and trip the overtemperature protection of the ES5300.1-A or the ES5300.1-B. For this reason, install front plates in all free slots!

Transport and Installation

To avoid damages to the hardware from electrostatic discharge, please observe the following precautionary measures:



CAUTION

Some components of the ES5372.1-B and the ES4455.2 or ES4456.2 to be installed can be damaged or destroyed by electrostatic discharges. Leave the plug-in cards in their transport packaging until their installation. Remove, configure and install the ES5372.1-B and the ES4455.2 or the ES4456.2 only at a workplace secured against static discharges.



CAUTION

In order to prevent damage to the plug-in boards and the LABCAR housing, and thereby also avoid damage to property or health, observe the installation instructions and information contained in the relevant User's Guides.



WARNING

Risk of electric shock, fire hazard!

For safety reasons, the assembly of the ES5372.1-B and ES4456.2 may be performed only at ETAS. If you purchased the two products individually, please contact your ETAS contact person so that the ES5372.1-B and the ES4456.2 can be returned to ETAS for assembly. Failure to observe it can lead to an incorrect pin assignment, damage to the board of the ES4456.2 or short circuits. This causes a risk of electric shock from high voltages and of fires.



CAUTION

If cards (e.g. for startup or calibration) are unlocked but not completely removed from the housing, they must be pulled out far enough that the distance between the respective card and the backplane of the housing is at least 1 cm. Otherwise, contacts may be established between the cards and lead to their destruction.

Connecting/Disconnecting Devices

To avoid injuries and hardware damages, observe the following precautionary measures:

- Do not apply any voltages to the connections of the ES5372.1-B that do not correspond to the specifications of the respective connection.
- Do not connect or disconnect any devices while the ES5300.1-A Housing or ES5300.1-B Housing or external devices are switched on. First, switch off the ES5300.1-A Housing or ES5300.1-B Housing by shutting down the real-time PC and by activating the On/Off switch at the rear and unplug the power cable.
- When plugging in connectors, ensure that they are inserted straight and no pins are bent.
- When crimping the plug contacts of Positronic, use only the crimping tool intended for this purpose.

Maintenance

The product does not require maintenance.

Repairs







If an ETAS hardware product needs to be repaired, return the product to ETAS.

Cleaning

The product is not expected to require cleaning.

1.3 Identifications on the Product

The following Symbols are Used for Product Labeling:

Symbol	Description
	The User's Guide must be read prior to the startup of the product
	W012 identification in accordance with DIN EN ISO 7010: "Warning about electrical voltage"
	Marking for CE conformity (see "CE Mark" on page 14)
	Marking for China RoHS (see "RoHS Conformity" on page 14)
	Marking for conformity with WEEE directive (see "Product Return and Recycling" on page 15)
	P007 identification in accordance with ISO 7010:2011: "No access for persons with pacemakers and implanted defibrillators". "Operational malfunction or damage to pacemakers and implanted defibrillators".

Observe the information in the chapter "Technical Data and Standards" on page 36.

1.3.1 CE Mark

With the CE mark attached to the product or its packaging, ETAS confirms that the product corresponds to the product-specific, applicable European Directives. The CE Declaration of Conformity for the product is available upon request.

1.3.2 RoHS Conformity

European Union

The EU directive 2011/65/EU limits the use of certain dangerous materials for electric and electronic devices (RoHS conformity).

ETAS confirms that the product meets this directive applicable in the European Union.

China

With the China RoHS identification attached to the product or its packaging, ETAS confirms that the product meets the guidelines of the "China RoHS" (Management Methods for Controlling Pollution Caused by Electronic Information Products Regulation) applicable in the People's Republic of China.

1.3.3 P007 Identification in Accordance with ISO 7010:2011

Under consideration of the standard ISO 7010:2011, the product is labeled with the symbol "No access for persons with pacemakers or implanted defibrillators".

The ES5372.1-B Carrier Board may be operated only in areas where persons with pacemakers are prohibited from entering. The user is obligated to attach a clearly legible P007 identification, "No access for persons with pacemakers or implanted defibrillators" in accordance with ISO 7010:2011 "Registered Safety Signs", at the entrances to these areas.

1.4 Product Return and Recycling

The European Union (EU) released the Directive for Waste Electrical and Electronic Equipment - WEEE to ensure the setup of systems for collecting, treating and recycling electronic waste in all countries of the EU.

This ensures that the devices are recycled in a resource-friendly way that does not represent any risk to personal health and the environment.



Fig. 1-3 WEEE symbol

The WEEE symbol on the product or its packaging identifies that the product may not be disposed of together with the remaining trash.

The user is obligated to separately collect old devices and provide them to the WEEE return system for recycling.

The WEEE Directive applies to all ETAS devices, but not to external cables or batteries.

Additional information about the recycling program of ETAS GmbH is available from the ETAS sales and service locations (see "ETAS Contact Addresses" on page 39).

1.5 Materials Subject to Declaration

Some products from ETAS GmbH (e.g. modules, boards, cables) use components with materials that are subject to declaration in accordance with the REACH regulation (EC) no.1907/2006.

Detailed information is located in the ETAS download center in the customer information "REACH Declaration" < www.etas.com/Reach >. This information is continuously being updated.

1.6 About this Manual

This manual consists of the following chapters:

- "Introduction" on page 4
This chapter
- "Setup, Installation and Fuses" on page 18
This chapter contains a description of the components of the ES5372.1-B. It also contains instructions for installation and information about the fuses.
- "Connections and Plug Connections" on page 27
This section provides a description of the different connections of the ES5372.1-B.
- "Technical Data and Standards" on page 36
This chapter contains the technical data of the ES5372.1-B and the applicable standards.
- "Ordering Data" on page 38

1.6.1 Working with this Manual

Presentation of Information

All activities to be performed by the user are presented in a "Use Case" format. That is, the goal to be accomplished is briefly defined in the heading, and the respective steps required for reaching this goal are then presented in a list. The presentation looks as follows:

Target Definition

Any advance information...

1. Step 1
Any explanation for step 1...
2. Step 2
Any explanation for step 2...

Any concluding comments...

Specific example:

Creating a New File

Before creating a new file, no other file may be open.

1. Select **File** → **New**.
The "Create File" dialog box appears.
2. Enter the name of the new file in the "File name" field.
The file name may not have more than 8 characters.
3. Click on **OK**.

The new file is being created and saved under the name you specified. You can now work with the file.

Typographical Conventions

The following typographical conventions are used:

Select File → Open .	Menu commands are displayed in bold/blue.
Click on OK .	Buttons are displayed in bold/blue.
Press <ENTER>.	Key commands are printed in small capitals enclosed in angle brackets.
The "Open file" dialog window appears.	Names of program windows, dialog windows, fields and similar are given in quotation marks.
Select the <code>setup.exe</code> file.	Text in selection lists, program code, as well as path and file names are displayed using the <code>Courier</code> font.
A conversion between the logical and arithmetic data types is <i>not</i> possible.	Content-based highlights and newly introduced terms are placed in <i>italics</i> .

Important notes for the user are presented as follows:

 **NOTE**

Important note for the user.

2 Setup, Installation and Fuses

This chapter contains a description of the components of the ES5372.1-B. It also contains instructions for installation and information about the fuses.

Fig. 2-1 shows the ES5372.1-B and the ES5372.1-B with installed ES4455.2 (center) and installed ES4456.2 (bottom).

The assembly instructions for the installation are located in chapter 2.4 on page 22.

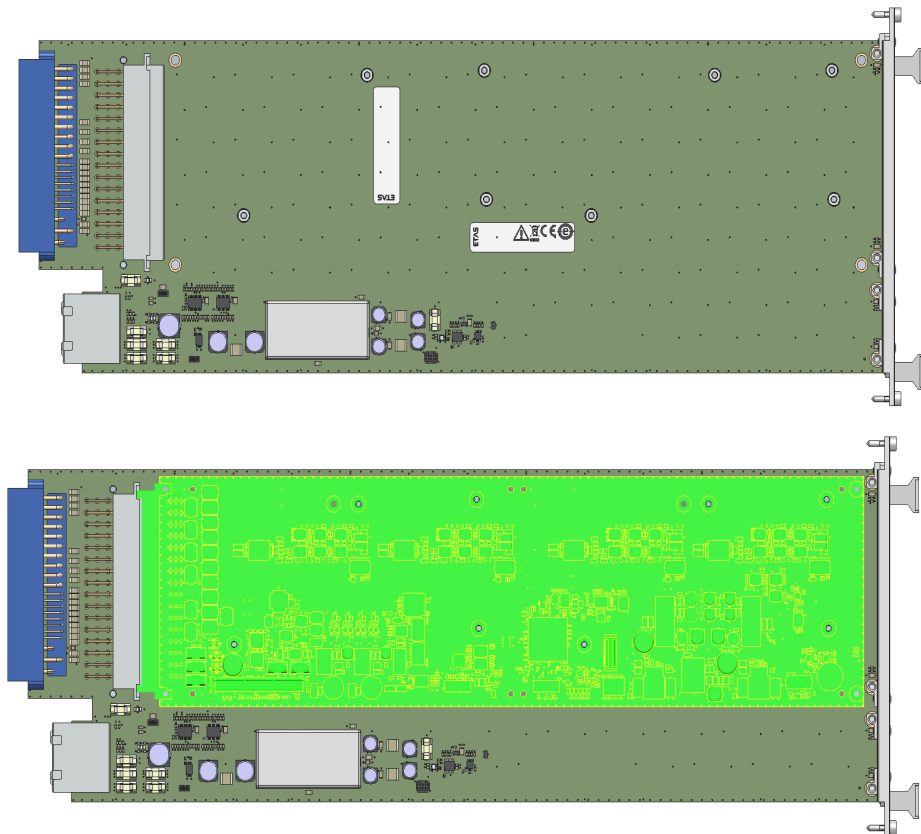

Fig. 2-1 ES5372.1-B unpopulated and with installed ES4455.2 (light green)

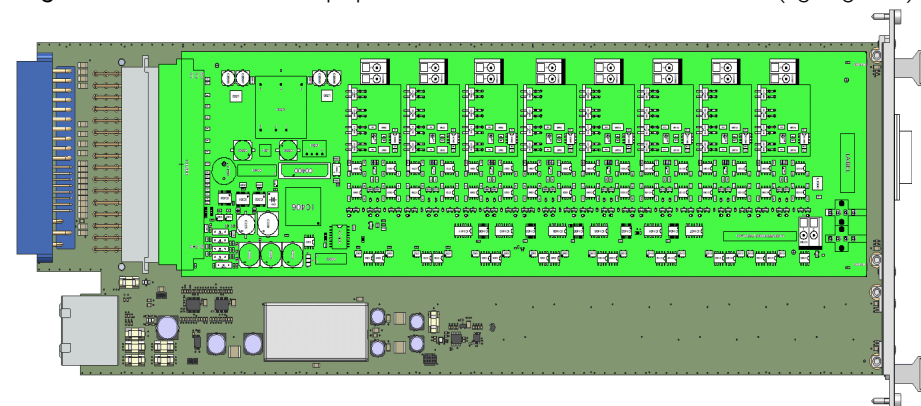

Fig. 2-2 ES5372.1-B with installed ES4456.2 (light green)

Front plate with pacemaker symbol

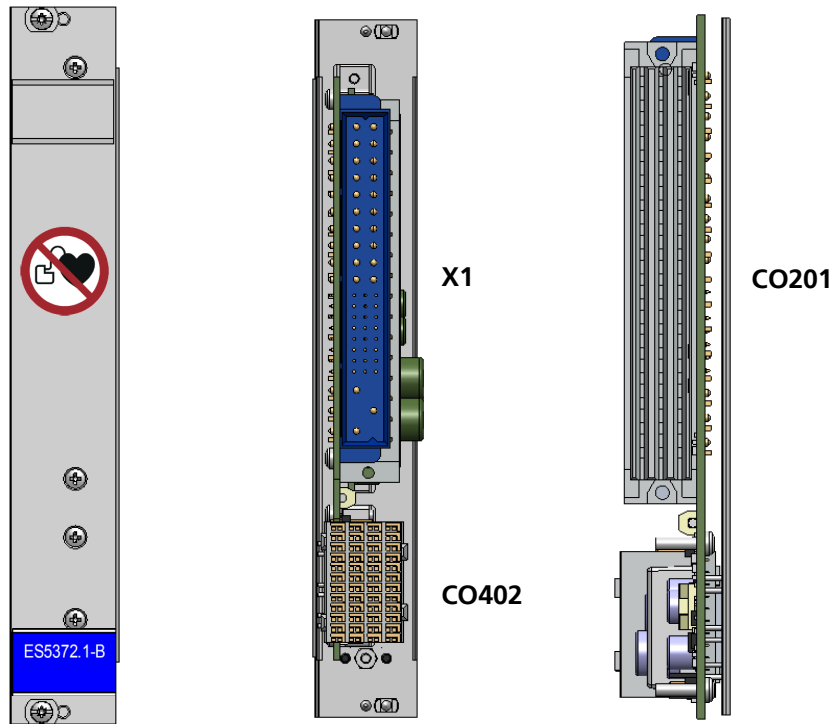

Fig. 2-3 Front plate (left), rear side plug connector (center) and plug connector for the ES4455.2 and ES4456.2 (right)



Fig. 2-4 Front plate with installed ES4456.2

2.1 Position of Plug Connections

The ES5372.1-B has various plug connectors for internal and external connections. The positions of the plug connectors are shown in Fig. 2-3.

The ES5372.1-B and plugged-in boards are supplied with voltage via the backplane of the ES5300.1-A Housing or the ES5300.1-B Housing. The electrical connection is done via plug connector CO402 (see "Backplane Connector CO402" on page 27).

CO201 is used to connect the ES4455.2 or the ES4456.2 with the ES5372.1-B.

All signals and load channels are connected to X1. In particular, X1 is used for connection to the following:

- External loads
- ECU
- ES5340.2-ICE for calibrating the injection signals (I_Dig_outx)
- Oscilloscope to the analog output for the online probe

If combined with ES4456.2, the load channels are connected to X2.

The pin assignment of the plug connections is located in "Connections and Plug Connections" on page 27.

2.2 Fuses

The voltages of the backplane of the ES5300.1-A Housing or the ES5300.1-B Housing are protected by four fuses on the ES5372.1-B. Two additional fuses FU100 can be installed for protecting external battery voltages (reference ground - VBAT).

Fig. 2-5 on page 21 shows the position of the fuses. Tab. 2-1 on page 21 lists the fuses with specification.

In case of a fuse defect, we recommend sending the board to ETAS for further testing. For this purpose, you should send the device to ETAS (see "ETAS Contact Addresses" on page 39).

If a fuse trips multiple times, the device must be sent to ETAS.



WARNING

Fire hazard!

Use only fuses that meet the specification in Tab. 2-1 on page 21! Never bridge defective fuses!

Failure to observe the fuse specification can lead to excess currents, short circuits and fires.



CAUTION

Replace fuses only with ES5372.1 Carrier Board removed! Observe "Installation / Removal of the ES5300.1-B into / from the ES5300.1-A Housing and ES5300.1-B Housing" on page 24 for this purpose.

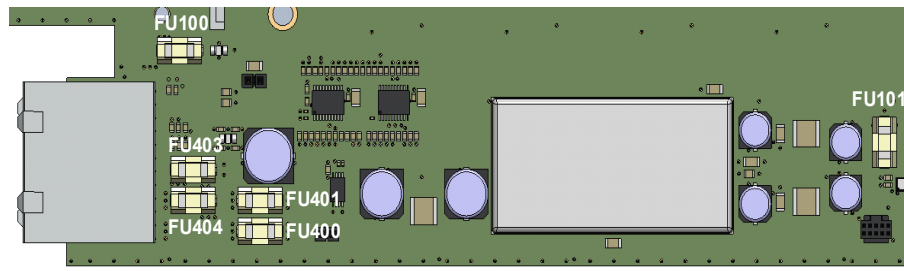

Fig. 2-5 Position of the fuses

Fuse	Type	Specification	Protection of (voltage)
FU100	NANO2® Slo-Blo® Fuse 452/454 Series	T5A	-VBAT
FU101	NANO2® Slo-Blo® Fuse 452/454 Series	not populated	not populated
FU400	NANO2® Slo-Blo® Fuse 452/454 Series	T3A	12 V
FU401	NANO2® Slo-Blo® Fuse 452/454 Series	T3A	3,3 V
FU403	NANO2® Slo-Blo® Fuse 452/454 Series	not populated	not populated
FU404	NANO2® Slo-Blo® Fuse 452/454 Series	T1.5A	-12 V

Tab. 2-1 Specification of the fuses on the ES5372.1-B

Position and specification of fuses on the ES4455.2 and ES4456.2 plug-in cards are described in the ES4455.2 user's guide or in the ES4456.2 user's guide.

2.3 Installing the ES4456.2 in an ES5372.1-B

The installation of the ES4456.2 may be performed only by ETAS.



WARNING

Risk of electric shock, fire hazard!

For safety reasons, the assembly of the ES5372.1-B and ES4456.2 may be performed only at ETAS. If you purchased the two products individually, please contact your ETAS contact person so that the ES5372.1-B and the ES4456.2 can be returned to ETAS for assembly. Failure to observe it can lead to an incorrect pin assignment, damage to the board of the ES4456.2 or short circuits. This causes a risk of electric shock from high voltages and of fires.

2.4 Installing the ES4455.2 in an ES5372.1-B

The ES4455.2 is used below to describe the installation in the ES5372.1-B.



CAUTION

The ES5372.1-B may be fitted only with the ES4455.2 or the ES4456.2. If other plug-in cards than the ES4455.2 or ES4456.2 are used, it may lead to damage of the ES5300.1-A Housing, ES5300.1-B Housing, the plug-in cards and/or damages to property and injuries.



CAUTION

Some components of the ES5372.1-B and the ES4455.2 or ES4456.2 to be installed can be damaged or destroyed by electrostatic discharges. Leave the plug-in cards in their transport packaging until their installation. Remove, configure and install the ES5372.1-B, the ES4455.2 and the ES4456.2 only at a workplace secured against static discharges.

Installing the ES4455.2 in an ES5372.1-B

The installation of the ES4455.2 is described below.

1. Ensure that ESD-compliant conditions exist at your workplace.

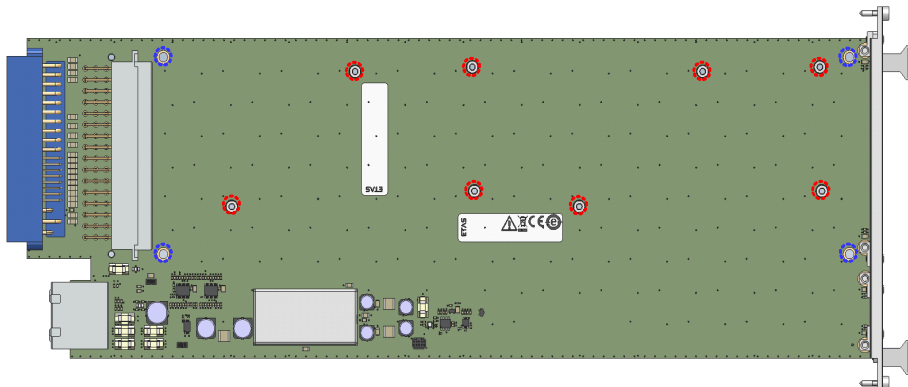

Fig. 2-6 ES5372.1-B with spacer bolts marked in red and blue

2. Guide the ES4455.2 (light green) at an angle from the top onto the ES5372.1-B and connect the plug connectors (Fig. 2-7).



NOTE

Ensure that the components and conductor paths on the back of the ES4455.2 are not damaged during installation.

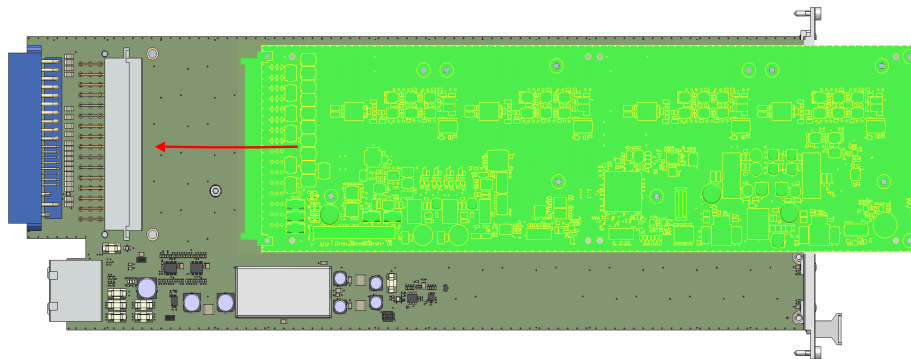

Fig. 2-7 Installation of an ES4455.2 (light green) in the ES5372.1-B

3. Place the 12 supplied washers on the drilled holes marked in red and blue in Fig. 2-8.
4. Install the supplied screws on the ES4455.2 Load Carrier Board using a T8 screwdriver.

i NOTE

The spacer bolts, the washers on the spacer bolts and the screws are electrical contacts between the ES5372.1-B and the ES4455.2. Install all screws and washers as described and ensure that the screws are sufficiently tightened (finger-tight).

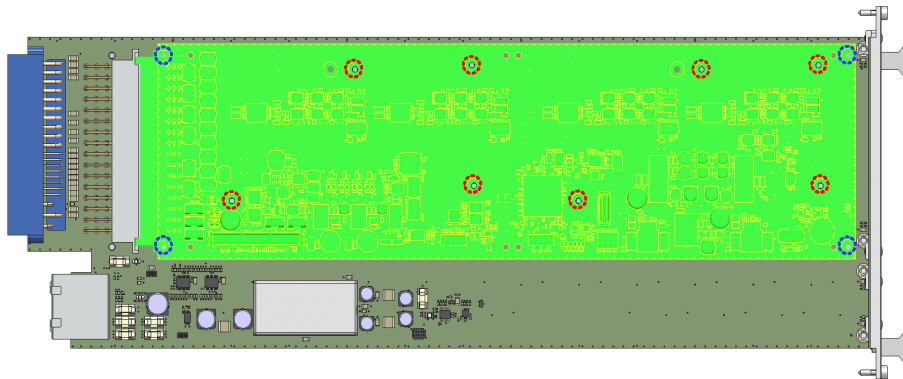

Fig. 2-8 Position of the drilled holes on the ES5372.1-B with installed ES4455.2

Red: electrical contacts, blue: mechanical connections

5. Place the small blue plate with the product description (ES4455.2) on the free space of the ES5372.1-B handle for product identification.

2.5 Installation / Removal of the ES5300.1-B into / from the ES5300.1-A Housing and ES5300.1-B Housing

This chapter describes how to install or remove the ES5372.1-B into or from the ES5300.1-A housing or into or from the ES5300.1-B housing.



WARNING

Danger through electromagnetic radiation!

The ES5372.1-B, fitted with the ES4455.2 or the ES4456.2 and loads connected to it, can emit electromagnetic radiation during operation which can cause interference with the operation or damage pacemakers or implanted defibrillators.

The ES5372.1-B may be operated only in areas where persons with pacemakers are prohibited from entering. At the entrances to these areas, the P007 identification, "No access for persons with pacemakers or implanted defibrillators" in accordance with ISO 7010:2011 "Registered Safety Signs", must be attached and clearly legible.

Failure to observe it can lead to health hazards and even death for persons with pacemakers and implanted defibrillators.



CAUTION

Do not install any plug-in cards while the ES5300.1-A Housing and/or the ES5300.1-B Housing is switched on. First, switch off the ES5300.1-A housing and/or the ES5300.1-B Housing by shutting down the real-time PC and by actuating the On/Off switch at the rear side.



DANGER

Danger from high voltages!

The components, plug connectors, conductor paths of the ES5372.1-B and the installed ES4455.2 or ES4456.2 may have dangerous voltages. These voltages can also be present when the ES5372.1-B is not installed in the ES5300.1-A Housing or in the ES5300.1-B Housing or the ES5300.1-A Housing or the ES5300.1-B Housing is switched off.

Ensure that the ES5372.1-B is protected against touching it during operation. Switch off the ES5300.1-A Housing or the ES5300.1-B Housing and pull the power plug. Wait at least three minutes before removing the ES5372.1-B.



CAUTION

Some components of the ES5372.1-B and the ES4455.2 or ES4456.2 to be installed can be damaged or destroyed by electrostatic discharges. Leave the plug-in cards in their transport packaging until their installation. Remove, configure and install the ES5372.1-B, the ES4455.2 and the ES4456.2 only at a workplace secured against static discharges.

**CAUTION**

While installing or removing the ES5372.1 Carrier Board into or from the ES5300.1-A Housing and the ES5300.1-B Housing, observe the following: Always guide the plug-in cards with both hands. The fitted cards are heavy and may fall if carried with one hand only.

**CAUTION**

The air circulation inside the ES5300.1-A housing and the ES5300.1-B housing can be ensured only if all free slots are covered with front plates. Otherwise, it may lead to overtemperatures and trip the overtemperature protection of the ES5300.1-A or the ES5300.1-B. For this reason, install front plates in all free slots!

**CAUTION**

If cards (e.g. for startup or calibration) are unlocked but not completely removed from the housing, they must be pulled out far enough that the distance between the respective card and the backplane of the housing is at least 1 cm. Otherwise, contacts may be established between the cards and lead to their destruction.

Installing the ES5372.1 Carrier Board in an ES5300.1-A Housing or ES5300.1-B Housing

1. Ensure that ESD-compliant conditions exist at your workplace.
2. Shut down the real-time PC and switch off the power supply of the ES5300.1-A or ES5300.1-B using the switch at the rear of the housing.
3. Wait at least three minutes for the components (capacitors, etc.) to be discharged.
4. Insert the ES5372.1-B (handle at the front plate with small blue plate must point down!) into the upper and lower rail of the slot and push it in a little bit.
5. Carefully push in the carrier card until the backplane connector of the ES5372.1-B is completely inserted in the socket of the backplane.

**NOTE**

Watch for cables in the insert area while pushing the card in – pull the lines into the front door area if necessary. While pushing in the card, ensure that the electrolytic capacitors of the ES4455.2 are not sheared off.

6. Fix the carrier card by fastening the front plate with screws.

7. Install front plates at all open slots before putting the ES5372.1-B into operation (see also the "Caution" safety note on Page 25).

Removing the ES5372.1-B from an ES5300.1-A Housing or ES5300.1-B Housing

1. Ensure that ESD-compliant conditions exist at your workplace.
2. Shut down the real-time PC and switch off the power supply of the ES5300.1-A or ES5300.1-B using the switch at the rear of the housing.
3. Wait at least three minutes for the components (capacitors, etc.) to be discharged (see also the "Warning" safety note on Page 24).
4. Loosen the screws on the front plate. Carefully guide the card out of the housing using both hands.

3 Connections and Plug Connections

This section provides a description of the different connections of the ES5372.1-B.



WARNING

Fire hazard!

Use only approved cables for creating cable assemblies (e.g. for connecting the ECU and external loads). The cables used must be suitable particularly for occurring currents, voltages and temperatures and flame-retardant in accordance with one of the following standards IEC 60332-1-2, IEC 60332-2-2, UL 2556/UL1581VW-1!

3.1 Backplane Connector CO402

The backplane connector CO402 forms the communication interface to the ES5300.1-A Housing and to the ES5300.1-B Housing. The CO402 is also used to provide the voltage supply for the ES5372.1-B.

Type: ERNI ERMet ZD 4-pair angled female multi-point connector (4-12) (order no. 973099)

Counterplug (in ES5300): ERNI ERMet ZD 4-pair straight male multi-point connector (4-12) (order no. 973096)

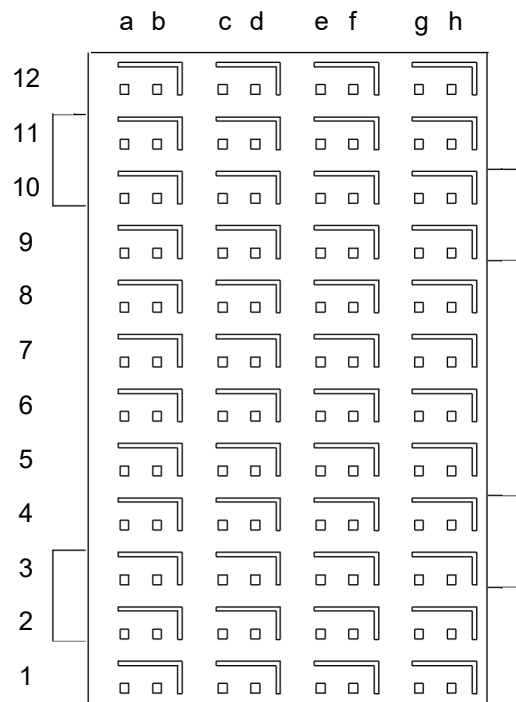

Fig. 3-1 Connector CO402 to backplane (top view)

The assignment of the pins is as follows (the maximum possible pin assignment for the ES5300.1-A Housing and the ES5300.1-B Housing is indicated here):

	h	g	f	e	d	c	e	a
12	GBLI_TX_n_0	GBLI_TX_p_0	GBLI_RX_n_0	GBLI_RX_p_0	M_LVDS_n_7	M_LVDS_p_7	BN_5	BN_4
12-shield	GND		GND		GND		GND	
11	GBLI_TX_n_1	GBLI_TX_p_1	GBLI_RX_n_1	GBLI_RX_p_1	M_LVDS_n_6	M_LVDS_p_6	SPI_CS_B_n	SPI_CS_A_n
11-shield	GND		GND		GND		GND	
10	GBLI_TX_n_2	GBLI_TX_p_2	GBLI_RX_n_2	GBLI_RX_p_2	M_LVDS_n_5	M_LVDS_p_5	SPI_MOSI	SPI_CLK
10-shield	GND		GND		GND		GND	
9	GBLI_TX_n_3	GBLI_TX_p_3	GBLI_RX_n_3	GBLI_RX_p_3	M_LVDS_n_4	M_LVDS_p_4	PCIE_WAKE_n	SPI_MISO
9-shield	GND		GND		GND		GND	
8	GBLI_PRESENT_n	GEO_ADDR_4	PCIE_REFCLK_n	PCIE_REFCLK_p	M_LVDS_n_3	M_LVDS_p_3	n.c.	n.c.
8-shield	GND		GND		GND		GND	
7	PCIE_RX_n_0	PCIE_RX_p_0	PCIE_TX_n_0	PCIE_TX_p_0	M_LVDS_n_2	M_LVDS_p_2	n.c.	n.c.
7-shield	GND		GND		GND		GND	
6	<i>Ass. internally</i>	<i>Ass. internally</i>	<i>Ass. internally</i>	<i>Ass. internally</i>	M_LVDS_n_1	M_LVDS_p_1	PCIE_JTAG_TCK	PCIE_JTAG_TDI
6-shield	GND		GND		GND		GND	
5	<i>Ass. internally</i>	<i>Ass. internally</i>	<i>Ass. internally</i>	<i>Ass. internally</i>	M_LVDS_n_0	M_LVDS_p_0	PCIE_JTAG_TDO	PCIE_JTAG_TMS
5-shield	GND		GND		GND		GND	
4	<i>Ass. internally</i>	<i>Ass. internally</i>	<i>Ass. internally</i>	<i>Ass. internally</i>	GEO_ADDR_1	GEO_ADDR_0	BN_3	BN_2
4-shield	GND		GND		GND		GND	
3	VCC24	VCC24	GEO_ADDR_3	GEO_ADDR_2	PCIE_SMBDAT	PCIE_SMBCLK	BN_1	BN_0
3-shield	VCC3_3		VCC3_3		VCC3_3		VCC3_3	
2	VSS12	VSS12	VCC3_3	VCC5	PCIE_PERST_n	PCIE_PRSENT1_n	PCIE_PRSENT2_n_X1	PCIE_PRSENT2_n_X4
2-shield	VCC12		VCC12		VCC12		VCC12	
1	VCC3_3	VCC3_3	VCC5	VCC5	VCC12	VCC12	VCC12	VCC12
1-shield	VCC12		VCC12		VCC12		VCC12	

3.2 Plug Connector X1

The plug connector X1 enable a connection of the ES5372.1-B to an ECU.

Fig. 3-2

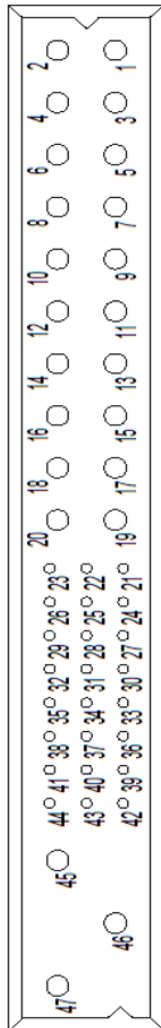

Fig. 3-2 Pin numbering of the plug connector X1

The pin assignment for the plug connector X1 is listed in Tab. 3-1 on page 31 and in Tab. 3-2 on page 32.

For a more detailed description of the functions of the installed ES4455.2 or ES4456.2, please read the ES4455.2 user's guide or the ES4456.2 user's guide or contact the Technical Support (see "ETAS Contact Addresses" on page 39).

3.2.1 Technical Details of Plug Connector X1

Below is the order information for connectors, counterplugs and crimp contacts.

Type: PCIH47M400A1, male

Manufacturer: Positronic

Order number: PCIH47M400A1/AA

Counterplug:

Type: PCIH47F8000, female

Manufacturer: Positronic

Order number: PCIH47F8000/AA

Crimp contacts:

Type: FC422N8

Count: 24

Manufacturer: Positronic

Order number: FC422N8/AA

Type: FC114N2

Count: 23

Manufacturer: Positronic

Order number: FC114N2/AA-1565.0

The counterplug and the crimp contacts are part of the scope of supply.

NOTE

When crimping the plug contacts of Positronic, use only the crimping tool intended for this purpose.

The pin assignment of X1 is as follows:

Pin Assignment of X1 for a ES4455.2 Equipped with ES5372.1-B

Short name	Type	#	PIN (signal)	PIN (ref.)	Short name
LOAD_1+	Connection for ECU	1	19	17	LOAD_1-
LOAD_2+	Connection for ECU	2	15	13	LOAD_2-
LOAD_3+	Connection for ECU	3	11	9	LOAD_3-
LOAD_4+	Connection for ECU	4	7	5	LOAD_4-
EXT_LOAD_1+	Connection for external load	1	20	18	EXT_LOAD_1-
EXT_LOAD_2+	Connection for external load	2	16	14	EXT_LOAD_2-
EXT_LOAD_3+	Connection for external load	3	3	1	EXT_LOAD_3-
EXT_LOAD_4+	Connection for external load	4	4	2	EXT_LOAD_4-
I_DIG_OUT_1	Digital output	1	29	25	GND_DIG_OUT*
I_DIG_OUT_2	Digital output	2	27	28	GND_DIG_OUT*
I_DIG_OUT_3	Digital output	3	32	31	GND_DIG_OUT*
I_DIG_OUT_4	Digital output	4	30	34	GND_DIG_OUT*
				22, 37, 40, 43	GND_DIG_OUT*
Online_Probe	Analog output		23	21	Online_Probe_Ref
				45, 46, 47	-VBAT
*) The pins 25, 28, 31, 34, 22, 37, 40 and 43 GND_DIG_OUT are internally connected to each other.					

Tab. 3-1 Pin assignment of X1 for ES4455.2

Pin Assignment of X1 for a ES4456.2 Equipped with ES5372.1-B

Short name	Type	#	PIN (signal)
V_Meas_Out_1	Analog output	1	23
V_Meas_Out_2	Analog output	2	21
V_Meas_Out_3	Analog output	3	26
V_Meas_Out_4	Analog output	4	24
V_Meas_Out_5	Analog output	5	29
V_Meas_Out_6	Analog output	6	27
V_Meas_Out_7	Analog output	7	32
V_Meas_Out_8	Analog output	8	30
AGND	Ground		22, 25, 28, 31, 34, 37, 40, 43

Tab. 3-2 Pin assignment of X1 for ES4456.2

3.3 Plug Connector X2 Load 0..7 on the Front Plate for Installed ES4456.2

The plug connector X2 "Load 0..7" is used for connecting the loads for the ES4456.2.

Type: ITT Cannon CA02COM-E20-29P-B (male)

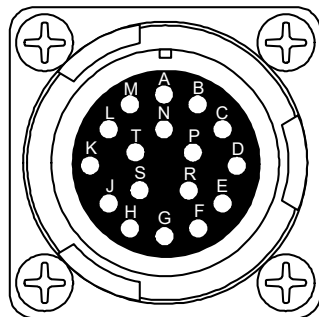

Fig. 3-3 Plug connector X2 Load 0..7



DANGER

Risk of electric shock!

At the plug X2 Load 0..7, high voltages may still be present even after disconnecting the counter plug.

After disconnecting the cable, wait one minute before touching the connections or the circuit board. Parallel to the capacitors are resistors that allow a safe discharging.

The pin assignment is as follows:

Pin	Signal	Pin	Signal
A	Load 1_High	Ch	Load 3_High
B	Load 2_High	L	Load 5_Low
C	Load 1_Low	M	Load 6_Low
D	Load 2_Low	N	Load 7_Low
E	Load 3_Low	P	Load 8_Low
F	Load 4_Low	R	Load 7_High
G	Load 5_High	S	Load 8_High
H	Load 6_High	T	n.c.
J	Load 4_High	Housing	Protective ground

Tab. 3-3 Pin assignment X2 Load 0..7

3.4 Plug Connector CO201 for ES4455.2 or ES4456.2

The plug connector CO201 is the electrical Interface between ES5372.1-B and ES4455.2 or ES4456.2.

The pin assignment of CO201 is described in Tab. 3-4 on page 34 and Tab. 3-5 on page 35.

Type: DIN41612_Type_F_MALE

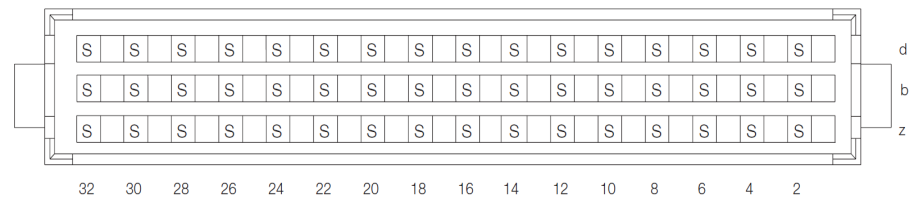

Fig. 3-4 Plug connector CO201

The pin assignment for the plug connector CO201 in the case of an installed ES4455.2 is as follows:.

Pin	Signal	Pin	Signal	Pin	Signal
z2	+12 V	b2	GND	d2	n.c.
z4	+5 V	b4	n.c.	d4	+3_3 V
z6	SPI_GTL_MISO	b6	SPI_GTL_MOSI	d6	SPI_GTL_CLK
z8	nCS0	b8	JTAG_TDI_CON	d8	JTAG_TDO_CON
z10	JTAG_TCK_CON	b10	JTAG_TMS_CON	d10	I_Dig_Out_1
z12	I_Dig_Out_2	b12	I_Dig_Out_3	d12	I_Dig_Out_4
z14	Online_Probe	b14	Online_Probe_GND	d14	n.c.
z16	n.c.	b16	I_Dig_Out_x_GND	d16	-UBAT
z18	Load 1+	b18	Load 1+	d18	Load 1+
z20	Load 1-	b20	Load 1-	d20	Load 1-
z22	Load 2+	b22	Load 2+	d22	Load 2+
z24	Load 2-	b24	Load 2-	d24	Load 2-
z26	Load 3+	b26	Load 3+	d26	Load 3+
z28	Load 3-	b28	Load 3-	d28	Load 3-
z30	Load 4+	b30	Load 4+	d30	Load 4+
z32	Load 4-	b32	Load 4-	d32	Load 4-

Tab. 3-4 Pin assignment CO201 for ES4455.2

The pin assignment for the plug connector CO201 in the case of an installed ES4456.2 is as follows:

Pin	Signal	Pin	Signal	Pin	Signal
z2	+12V	b2	GND	d2	-12V
z4	+5V	b4	VCC24	d4	+3,3V
z6	SPI_GTL_MISO	b6	SPI_GTL_MOSI	d6	SPI_GTL_CLK
z8	nCS0	b8	JTAG_TDI_CON	d8	JTAG_TDO_CON
z10	JTAG_TCK_CON	b10	JTAG_TMS_CON	d10	V_Meas_Out_1
z12	V_Meas_Out_2	b12	V_Meas_Out_3	d12	V_Meas_Out_4
z14	V_Meas_Out_5	b14	V_Meas_Out_6	d14	V_Meas_Out_7
z16	V_Meas_Out_8	b16	V_Meas_GND	d16	n. c.
z18	n. c.	b18	n. c.	d18	n. c.
z20	n. c.	b20	n. c.	d20	n. c.
z22	n. c.	b22	n. c.	d22	n. c.
z24	n. c.	b24	n. c.	d24	n. c.
z26	n. c.	b26	n. c.	d26	n. c.
z28	n. c.	b28	n. c.	d28	n. c.
z30	n. c.	b30	n. c.	d30	n. c.
z32	n. c.	b32	n. c.	d32	n. c.

Tab. 3-5 Pin assignment CO201 for ES4456.2 (update pin assignment for ES4456.2)



WARNING

The plug connector CO201 is permitted only as interface for ES4455.2 and ES4456.2. If other plug-in cards than the ES4455.2 or ES4456.2 are used, it may lead to damage of the ES5300.1-A Housing, ES5300.1-B Housing, the plug-in cards and/or damages to property and injuries.

4 Technical Data and Standards

This chapter contains the technical data of the ES5372.1-B and the applicable standards.

4.1 Technical Data

Plug Connector X1 Equipped with ES4455.2

Pins 1-20, 45,46,47 (load channels)	
Abs. max. load current	+/- 20 A für max. 1 ms
Abs. max. load voltage per channel	+/- 60 V DC für max. 1 ms
Abs. max. duty cycle	25%
Max. power	50 W rms (root meansquare)
Pins 21-44	
Max. current	+/- 1 A
Max. voltage	+/- 60 V DC

Plug Connector X1 Equipped with mit ES4456.2

Pins 1-47	
Max. current	+/- 1 A
Max. voltage	+/- 60 V DC



CAUTION

The abs. max. load current, abs. max. load voltage, abs. max. duty cycle and maximum permissible power of 50 W rms must not be exceeded. If one or several of these values are exceeded, the ES5372.1-B, the cards installed in the ES5372.1-B and the injector load can be damaged, or an undefined behavior can occur (e.g. emergency shutdown of injector load).

Voltage Supply (Backplane Connector)

Max. permissible power consumption from backplane	25 W at 12 V
	4 W at 5 V
	8 W at 3,3 V

Load Channels at Plug Connector X2 "Load 0..7"

If an ES4456.2 is installed, please observe the technical data in the ES4456.2 user's guide for the plug connector "Load 0..7".

Storage Conditions

Temperature	-20 °C to 85 °C (-4 °F to 185 °F)
Relative humidity	0 to 95% (non-condensing)

Ambient Conditions

Environment	Use only inside enclosed and dry rooms
Max. contamination level	2
Temperature during operation	5 °C to 40 °C (41 °F to 104 °F)
Relative humidity	0 to 95% (non-condensing)
Operating altitude	Max. 2000 m above sea level

Physical Dimensions of the ES5372.1-B Carrier Board

Height	3 U
Width	14 HP
Depth	340 mm
Weight	0.5 kg

4.2

Standards Met

The ES5372.1 Carrier Board meets the following standards:

Standard	Test
IEC 61326-1	Electrical equipment for measurement, control and laboratory use – EMC requirements (industrial setting)
IEC 61010-1	Safety requirements for electrical equipment for measurement, control and laboratory use - Part 1: General requirements

The board is only intended for use in industrial settings in accordance with EN 61326-1. Avoid potential radio interference when using the module outside of the industrial settings with additional shielding measures!



WARNING

This is class A equipment. This equipment can cause radio interference in residential areas. Should that be the case, the operator may be requested to institute reasonable measures.



NOTE

The signal lines may not exceed a maximum length of 3 m!

5 Ordering Data

The ordering data for the ES5372.1-B Carrier Board are as follows:

Order name	Short name	Order number
ES5372.1-B 1 Slot Carrier Board for ES4455.2 and ES4456.2	ES5372.1-B	F-00K-110-689
Scope of delivery	Number of pieces	
ES5372.1-B 1 Slot Carrier Board for ES4455.2 and ES4456.2	1	
Counter plug: Type: PCIH47F8000, female Manufacturer: Positronic	1	PCIH47F8000/ AA
Crimp contacts Type: FC422N8 Manufacturer: Positronic	24	FC422N8/AA
Crimp contacts Type: FC114N2 Manufacturer: Positronic	23	FC114N2/AA- 1565.0
Washers	12	
Screws T8	12	

6 ETAS Contact Addresses

ETAS HQ

ETAS GmbH

Borsigstraße 24
70469 Stuttgart
Germany

Phone: +49 711 3423-0
Fax: +49 711 3423-2106
WWW: www.etas.com

ETAS Subsidiaries and Technical Support

For details of your local sales office as well as your local technical support team and product hotlines, take a look at the ETAS website:

ETAS subsidiaries WWW: www.etas.com/en/contact.php
ETAS technical support WWW: www.etas.com/en/hotlines.php

Index

A		
Accident prevention	8	
Application areas	4	
B		
Basic safety notices	7	
C		
CE Declaration of Conformity	14	
Connecting devices	13	
Connections and Connectors	27	
Backplane connector CO402	27	
CO301	33	
X1 Measure	29	
X2 Load	29	
D		
Defibrillators	14	
Devices		
Connecting	13	
E		
Electrical safety	9	
ETAS Contact Addresses	39	
F		
Fuses	18, 20	
G		
General safety information	7	
I		
Identification of safety notices	7	
Identifications on the product	14	
Improper use	8	
Installation	18	
Intended	8	
Intended use	9	
O		
Ordering data	38	
P		
Pacemaker	14	
Product return	15	
Q		
Qualification, required	8	
R		
Recycling	15	
Removal	26	
RoHS conformity		
China	14	
European Union	14	
S		
Safety at work	8, 9	
Safety precautions	7	
Signal lines	37	
Standards	36, 37	
		Storage conditions
		37
		T
		Technical Data
		36
		W
		Waste Electrical and Electronic Equipment
		15
		WEEE return system
		15