

# ES5372.1 Carrier Board for ES4455 Load Boards

## User's Guide



## Copyright

---

The data in this document may not be altered or amended without special notification from ETAS GmbH. ETAS GmbH undertakes no further obligation in relation to this document. The software described in it can only be used if the customer is in possession of a general license agreement or single license. Using and copying is only allowed in concurrence with the specifications stipulated in the contract.

Under no circumstances may any part of this document be copied, reproduced, transmitted, stored in a retrieval system or translated into another language without the express written permission of ETAS GmbH.

© **Copyright 2019** ETAS GmbH, Stuttgart

The names and designations used in this document are trademarks or brands belonging to the respective owners.

V1.0.0 R06 EN - 09.2019

---

## Contents

1	Introduction	5
1.1	Properties	6
1.1.1	Properties of the ES5372.1 Carrier Board for ES4455 Load Boards	6
1.1.2	Block Diagram with ES5372.1 Carrier Board for ES4455 Load Boards	6
1.2	Basic Safety Notices	9
1.2.1	Identification of Safety Notices	9
1.2.2	General Safety Information	9
1.2.3	Requirements for Users and Duties for Operators	9
1.2.4	Intended Use	10
1.3	Identifications on the Product	15
1.3.1	CE Mark	16
1.3.2	KC Mark	16
1.3.3	RoHS Conformity	16
1.3.4	P007 Identification in Accordance with ISO 7010:2011	16
1.4	Product Return and Recycling	17
1.5	Materials Subject to Declaration	17
1.6	About this Manual	18
1.6.1	Working with this Manual	18
2	Design, Installation and Fuses	21
2.1	Position of Plug Connections	22
2.2	Fuses	23
2.3	Installation of an ES445x.y Load Carrier Board in an ES5372.1 Carrier Board	25
2.4	Installation / Removal of the ES5372.1 Carrier Board into/from the ES5300.1-A Housing and ES5300.1-B Housing	28
3	Connections and Plug Connections	33
3.1	Backplane Connector CO300	33
3.2	X1 Measure and X2 Load Connectors	35

3.2.1	X2 Load Plug Connector . . . . .	36
3.2.2	X1 Measure Connector . . . . .	36
3.3	CO301 Connector for ES445x.y Load Carrier Boards . . . . .	37
3.4	X3 Battery Voltage Connector . . . . .	38
4	Technical Data and Standards . . . . .	39
4.1	Technical Data . . . . .	39
4.2	Standards Met . . . . .	40
5	Ordering Data . . . . .	41
6	ETAS Contact Addresses . . . . .	43
	Index . . . . .	45

## 1 Introduction

This User's Guide contains the description of the ES5372.1 Carrier Board for ES4455 Load Boards. The ES5372.1 Carrier Board is an adapter card that allows operating the ES4455.2 plug-in cards in the ES5300.1-A Housing and the ES5300.1-B Housing.

The ES4455.2 plug-in cards that can be used in the ES5372.1 Carrier Board are summarized in Tab. 1-1.

ES4455.2 Load Carrier Board
ES4450.3 Load Carrier Board for 4 RB CRS Injectors
ES4451.4 Load Carrier Board for 4 RB GDI Injectors
ES4452.1 Load Carrier Board for 4 RB GDI Injectors, CVO
ES4453.2 Load Carrier Board for 4 RB HDEV6 Injectors
ES4457.1 Load Carrier Board for 4 RB CRS Injectors, VCC and VCA
ES4458.1 Load Carrier Board for 4 PFI Injectors, CVO

**Tab. 1-1** ES4455.2 plug-in cards for use in the ES5372.1 Carrier Board.

This chapter contains information about the following topics:

- "Properties" on page 6
- "Basic Safety Notices" on page 9
- "Identifications on the Product" on page 15
- "CE Mark" on page 16
- "KC Mark" on page 16
- "RoHS Conformity" on page 16
- "Product Return and Recycling" on page 17
- "Materials Subject to Declaration" on page 17
- "About this Manual" on page 18

## 1.1 Properties

---

This chapter describes the fundamental properties of the ES5372.1 Carrier Board for ES4455 Load Boards.

### 1.1.1 Properties of the ES5372.1 Carrier Board for ES4455 Load Boards

---

The ES5372.1 Carrier Board for ES4455 Load Boards is an add-on card for a LABCAR HiL system for use in the ES5300.1-A Housing and in the ES5300.1-B Housing. The ES5372.1 Carrier Board can be populated with the ES4455.2 plug-in cards listed in Tab. 1-1 on page 5. This enables the simulation of four inductive injector loads.

The properties of the ES5372.1 Carrier Board are as follows:

- 3 U / 14 HP (3 slots) plug-in card for a LABCAR HiL system.
- Compatibility with ES5300.1-A Housing and ES5300.1-B Housing
- Slot for an ES4455.2 plug-in card from Tab. 1-1 on page 5
- Mapping of four inductive / ohmic loads in populated condition
- For additional specific properties in the populated condition, see also the ES4455.2 User's Guide.

### 1.1.2 Block Diagram with ES5372.1 Carrier Board for ES4455 Load Boards

---

The block diagram in Fig. 1-1 on page 7 shows the ES5372.1 Carrier Board, populated with an ES4455.2 Load Carrier Board and installed in the ES5300.1-A Housing or ES5300.1-B Housing.

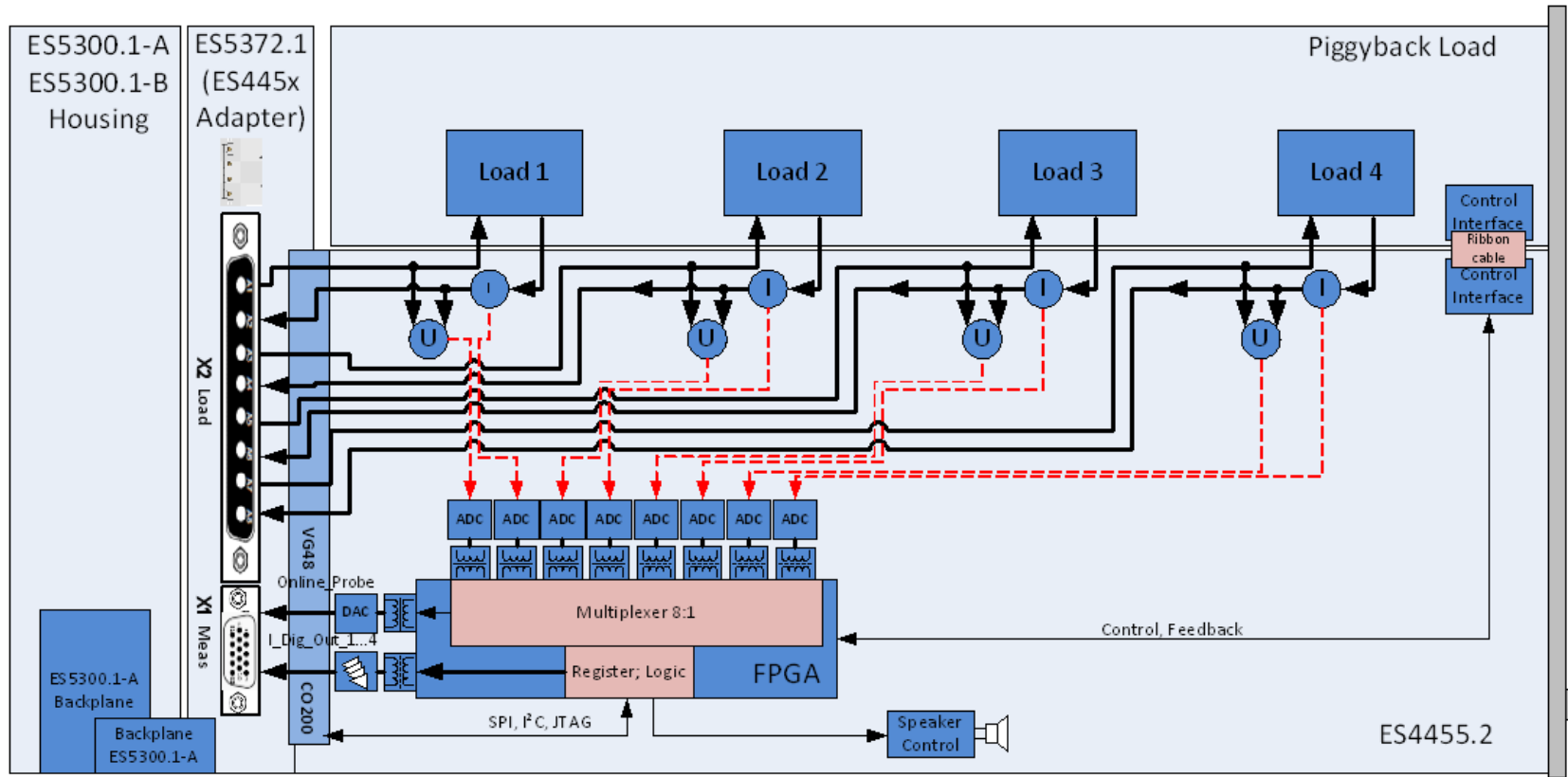

**Fig. 1-1** Block diagram of the ES5372.1 Carrier Board, populated with an ES4455.2 Load Carrier Board and installed in the ES5300.1-A Housing or ES5300.1-B Housing

Fig. 1-2 shows an example for the use of the ES5372.1 Carrier Board in an HiL system.

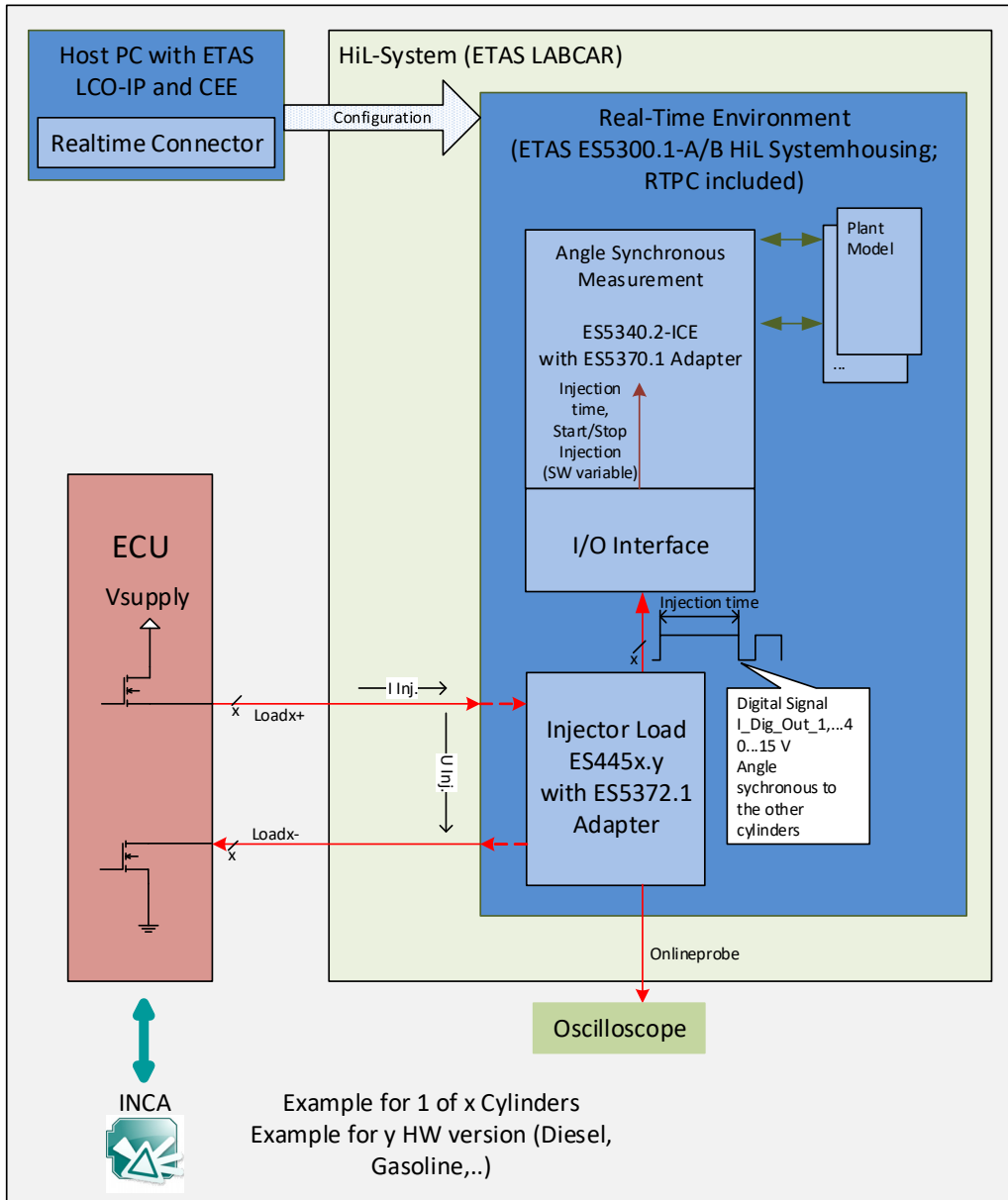

**Fig. 1-2** Example for integrating an ES5372.1 Carrier Board in a LABCAR HiL system

For more information about the ES445x.y Load Carrier Boards, see the ES4455.2 User's Guide.



## 1.2 Basic Safety Notices

---

Observe the following safety notices to avoid health issues or damage to the device.

### 1.2.1 Identification of Safety Notices

---

The safety notices contained in this manual are identified with the danger symbol shown below:



The safety notices shown below are used for this purpose. They provide notes to extremely important information. Please read this information carefully.

**CAUTION!**

*identifies a hazard with low risk that could result in minor or medium physical injuries or property damages if not avoided.*

**WARNING!**

*indicates a possible danger with moderate risk of death or (serious) injury, if not avoided.*

**DANGER!**

*indicates an immediate danger with a high risk of death or serious injury, if not avoided.*

### 1.2.2 General Safety Information

---

Observe the following safety notices to avoid health issues or damage to the device.

**Note**

*All product related documentation (product Safety Advice and this User's Guide) must be read prior to the startup of the product!*

ETAS GmbH does not assume any liability for damages resulting from improper handling, unintended use or non-observance of the safety precautions.

### 1.2.3 Requirements for Users and Duties for Operators

---

The product may be assembled, operated and maintained only if you have the necessary qualification and experience for this product. Improper use or use by a user without sufficient qualification can lead to damages or injuries to one's health or damages to property.

The system integrator is responsible for the safety of systems that use the product.

### *General Safety at Work*

---

Follow the existing regulations for work safety and accident prevention. All applicable regulations and laws regarding operation must be strictly adhered to when using this product.

#### 1.2.4 Intended Use

---

The ES5372.1 Carrier Board is a plug-in card for the ES5300.1-A Housing and the ES5300.1-B Housing. The ES5372.1 Carrier Board serves to accept ES4455.2 Load Boards (see Tab. 1-1 on page 5).

The ES5372.1 Carrier Board consists of the following:

- Slot for ES4455.2 plug-in cards from Tab. 1-1 on page 5
- SPI interface to the ES5300.1-A Housing or ES5300.1-B Housing for the configuration of ES445x.y plug-in cards from Tab. 1-1 on page 5
- Output interface (current outputs) to the ECU
- Voltage supply of the ES445x plug-in card
- Replacement load simulation for connecting to ECU output stages
- Interface for the battery voltage  
(Mapping the vehicle battery itself is not part of the ES5300.1-A Housing or ES5300.1-B Housing and cannot even be installed here.)

The ES5372.1 Carrier Board may be installed and operated only in the ES5300.1-A Housing or in the ES5300.1-B Housing.

The intended use of the ES5372.1 Carrier Board in an ES5300.1-A Housing or in an ES5300.1-B Housing is as follows:

- Use as part of industrial lab facilities or at workplaces
- Use as hardware interface for ECUs in a hardware-in-the-loop test system
- Use in conjunction with ETAS software that support the ES5300.1-A Housing and the ES5300.1-B Housing
- Use as interface in cooperation with software programs that operate the standardized, documented and open APIs of ETAS software products.

The ES5372.1 Carrier Board is not intended for the following:

- Use within a vehicle on the road
- Use as part of a life support system
- Use as part of a medical application
- In applications where misuse can lead to injuries or damages
- Use in environments in which conditions prevail that fall outside the specified ranges (see "Ambient Conditions" on page 40)
- Use with signal conditioning that falls outside the specified ranges (see voltages, currents and power consumption in the chapter "Technical Data" on page 39)

### *Requirements for the Technical State of the Product*

---

The product is designed in accordance with state-of-the-art technology and recognized safety rules. The product may be operated only in a technically flawless condition and according to the intended purpose and with regard to safety and dangers as stated in the respective product documentation. If the product is not used according to its intended purpose, the protection of the product may be impaired.

### *Requirements for Operation*

---

The following requirements are necessary for safe operation:

- Use the product only according to the specifications in the corresponding User's Guide. With any deviating operation, the product safety is no longer ensured.
- Do not use the product in a wet or damp environment.
- Do not use the product in potentially explosive atmospheres.

### *Electrical Safety and Power Supply*

---

Observe the regulations applicable at the operating location concerning electrical safety as well as the laws and regulations concerning work safety!

**WARNING!**

*Danger of high voltages!*

*The components, connectors, printed circuits and installed ES445x.y Load Carrier Boards of the ES5372.1 Carrier Board can carry dangerous voltages. These voltages can also be present when the ES5372.1 Carrier Board is not installed in the ES5300.1-A Housing or in the ES5300.1-B Housing or the ES5300.1-A Housing or ES5300.1-B Housing is switched off.*

*Ensure that the ES5372.1 Carrier Board is protected against any contact during operation. Switch off the ES5300.1-A Housing or ES5300.1-B Housing and pull the power plug. Wait at least three minutes before uninstalling the ES5372.1 Carrier Board.*

**WARNING!**

*Danger through electromagnetic radiation!*

*The ES5372.1 Carrier Board may emit electromagnetic radiation during operation which can interfere with the operation or cause damage to pacemakers and implanted defibrillators.*

*The ES5372.1 Carrier Board may be operated only in areas to which persons with pacemakers have no access. The entrances to these areas must show the designation P007 "No access for persons with pacemakers or implanted defibrillators" in accordance with ISO 7010:2011 "Registered Safety Signs" and must be clearly visible. Failure to observe it can lead to health hazards and even death for persons with pacemakers and implanted defibrillators.*

**WARNING!**

*Fire hazard!*

*Use only fuses that meet the specification in Tab. 1-1 on page 5!*

*Never bridge defective fuses!*

*Failure to observe the fuse specification can lead to excess currents, short circuits and fires.*

### *Power Supply*

---

The product is powered by the ES5300.1-A Housing or the ES5300.1-B Housing via the PCIe Backplane Connector.

*Insulation Requirements for Lab Power Supplies to Circuits Connected to the HIL System:*

---

- The power supply to live circuitry must be safely isolated from the supply voltage. For example, use a car battery or a suitable lab power supply.
- Only use lab power supplies with dual protection for the supply network (with double/reinforced insulation (DI/RI)). This requirement is met by lab power supplies that comply with IEC/EN 60950 or IEC/EN 61010.
- The lab power supply must be approved for use at a height of 2000 m and in ambient temperatures of up to 40 °C.

### *De-energizing a Plug-in Board*

---

Switch off the ES5300.1-A Housing or the ES5300.1-B Housing and external power supplies, and unplug the power plug and other connectors attached to the plug-in board. Wait at least three minutes before removing the plug-in board.

### *Approved Cables*

---

The signal lines must not exceed a maximum length of 3 m.

**WARNING!**

*Fire hazard!*

*Use only approved cables for creating cable assemblies (e.g. for connecting the ECU and external loads). The cables used must be suitable particularly for occurring currents, voltages and temperatures and flame-retardant in accordance with one of the following standards IEC 60332-1-2, IEC 60332-2-2, UL 2556/UL1581VW-1!*

### *Requirements for the Installation Location*

---

**WARNING!**

*This is class A equipment. This equipment can cause radio interference in residential areas. Should that be the case, the operator may be requested to institute reasonable measures.*

### Requirements for Ventilation

---

**CAUTION!**

The air circulation inside the ES5300.1-A housing and the ES5300.1-B housing can be ensured only if all free slots are covered with front plates. Otherwise, it may lead to overtemperatures and trip the over-temperature protection of the ES5300.1-A or the ES5300.1-B. For this reason, install front plates in all free slots!

### Transport and Installation

---

To avoid damages to the hardware from electrostatic discharge, please observe the following precautionary measures:

**CAUTION!**

Some components of the ES5372.1 Carrier Board and the plug-in cards listed in Tab. 1-1 on page 5 can be damaged or destroyed by electrostatic discharges. Leave the plug-in cards in their transport packaging until their installation. The ES5372.1 Carrier Board and the plug-in cards listed in Tab. 1-1 on page 5 should only be removed, configured and installed at a workplace that is secured against static discharges.

**WARNING!**

Fire hazard!  
The ES5372.1 Carrier Board for ES4455 Load Boards may be populated only with the plug-in cards listed in Tab. 1-1 on page 5. If other plug-in cards than those in Tab. 1-1 on page 5 are used, it can lead to damages to the ES5300.1-A Housing, ES5300.1-B Housing, the plug-in cards and/or damages to property and personal injury.

**CAUTION!**

In order to prevent damage to the plug-in boards and the LABCAR housing, and thereby also avoid damage to property or health, observe the installation instructions and information contained in the relevant User's Guides.

**CAUTION!**

If cards (e.g. for startup or calibration) are unlocked but not completely removed from the housing, they must be pulled out far enough that the distance between the respective card and the back-plane of the housing is at least 1 cm. Otherwise, contacts may be established between the cards and lead to their destruction.

### *Connecting/Disconnecting Devices*

---

To avoid injuries and hardware damages, observe the following precautionary measures:

- Do not apply any voltages to the connections of the ES5372.1 Carrier Board that do not correspond to the specifications of the respective connection.
- Do not connect or disconnect any devices while the ES5300.1-A Housing or ES5300.1-B Housing or external devices are switched on. First, switch off the ES5300.1-A Housing or ES5300.1-B Housing by shutting down the real-time PC and by activating the On/Off switch at the rear and unplug the power cable.
- When plugging in connectors, ensure that they are inserted straight and no pins are bent.

### *Maintenance*

---

The product does not require maintenance.

### *Repairs*

---

If an ETAS hardware product needs to be repaired, return the product to ETAS.







### *Cleaning*

---

The product is not expected to require cleaning.

### 1.3 Identifications on the Product

*The following Symbols are used for Product Labeling:*

Symbol	Description
	The User's Guide must be read prior to the startup of the product
	Marking for CE conformity (see "CE Mark" on page 16)
	Marking for KCC conformity (see "KC Mark" on page 16)
	Marking for China RoHS (see "RoHS Conformity" on page 16)
	Marking for conformity with WEEE directive (see "Product Return and Recycling" on page 17)
	P007 identification in accordance with ISO 7010:2011: "No access for persons with pacemakers and implanted defibrillators." "Operational malfunction or damage to pacemakers and implanted defibrillators".

Observe the information in the chapter "Technical Data and Standards" on page 39.

### 1.3.1 CE Mark

---

With the CE mark attached to the product or its packaging, ETAS confirms that the product corresponds to the product-specific, applicable European Directives. The CE Declaration of Conformity for the product is available upon request.

### 1.3.2 KC Mark

---

With the KC mark attached to the product and its packaging, ETAS confirms that the product has been registered in accordance with the product-specific KCC guidelines of the Republic of Korea.

### 1.3.3 RoHS Conformity

---

#### *European Union*

---

The EU Directive 2011/65/EU limits the use of certain dangerous materials for electric and electronic devices (RoHS conformity).

ETAS confirms that the product meets this directive applicable in the European Union.

#### *China*

---

ETAS confirms that the product meets the "China RoHS" (Management Methods for Controlling Pollution Caused by Electronic Information Products Regulation) guidelines applicable to the People's Republic of China with a China RoHS label attached to the product or its packaging.

### 1.3.4 P007 Identification in Accordance with ISO 7010:2011

---

Under consideration of the standard ISO 7010:2011, the product is identified with the symbol "No access for persons with pacemakers or implanted defibrillators".

The ES5372.1 Carrier Board may be operated only in areas to which persons with pacemakers have no access. The user is obligated to attach the clearly visible designation P007 "No access for persons with pacemakers or implanted defibrillators" in accordance with ISO 7010:2011 "Registered Safety Signs" at the entrances to these areas.



## 1.4 Product Return and Recycling

---

The European Union (EU) has issued the guideline on waste electric and electronic equipment (Waste Electrical and Electronic Equipment - WEEE) in order to ensure the institution of systems for collection, handling, and disposal of all electronic scrap.

This ensures that the devices are recycled in a resource-friendly way that does not represent any risk to personal health and the environment.



**Fig. 1-3** WEEE symbol

The WEEE symbol on the product or its packaging identifies that the product may not be disposed of together with the remaining trash.

The user is obligated to separate the waste equipment and to provide it to the WEEE return system for reuse.

The WEEE Directive applies to all ETAS devices, but not to external cables or batteries.

Additional information about the recycling program of ETAS GmbH is available from the ETAS sales and service locations (see "ETAS Contact Addresses" on page 43).

## 1.5 Materials Subject to Declaration

---

Some products from ETAS GmbH (e.g. modules, boards, cables) use components with materials that are subject to declaration in accordance with the REACH regulation (EC) no.1907/2006.

Detailed information is located in the ETAS download center in the customer information "REACH Declaration" < [www.etas.com/Reach](http://www.etas.com/Reach) >. This information is continuously being updated.

## 1.6 About this Manual

---

This manual consists of the following chapters:

- "Introduction" on page 5  
This chapter
- "Design, Installation and Fuses" on page 21  
This chapter contains a description of the components of the ES5372.1 Carrier Board. It also features instructions for the installation and information about the fuses.
- "Connections and Plug Connections" on page 33  
This section provides a description of the different connections of the ES5372.1 Carrier Board.
- "Technical Data and Standards" on page 39  
This chapter contains the technical data of the ES5372.1 Carrier Board for ES4455 Load Boards and the valid standards.
- "Ordering Data" on page 41

### 1.6.1 Working with this Manual

---

#### *Presentation of Information*

---

All activities to be performed by the user are presented in a "Use Case" format. That is, the goal to be accomplished is briefly defined in the heading, and the respective steps required for reaching this goal are then presented in a list. The presentation looks as follows:

#### **Target Definition**

---

Any advance information...

1. Step 1  
Any explanation for step 1...
2. Step 2  
Any explanation for step 2...

Any concluding comments...

#### **Specific example:**

#### **Creating a New File**

---

Before creating a new file, no other file may be open.

1. Select **File** → **New**.  
The "Create File" dialog box appears.
2. Enter the name for the file in the "File Name" field.  
The file name may not have more than 8 characters.
3. Click on **OK**.

The new file is being created and saved under the name you specified. You can now work with the file.

### *Typographical Conventions*

---

The following typographical conventions are used:

Select <b>File</b> → <b>Open</b> .	Menu commands are displayed in bold/blue.
Click on <b>OK</b> .	Buttons are displayed in bold/blue.
Press <ENTER>.	Keyboard commands are presented in angled brackets starting with capital letter.
The "Open file" dialog window appears.	Names of program windows, dialog windows, fields and similar are set in quotation marks.
Select the <code>setup.exe</code> file.	Text in selection lists, program code, as well as path and file names are displayed using the <code>Courier</code> font.
A conversion between the logical and arithmetic data types is <i>not</i> possible.	Content-based highlights and newly introduced terms are placed in <i>italics</i> .

Important notes for the user are presented as follows:

**Note**

*Important note for the user.*



## 2 **Design, Installation and Fuses**

This chapter contains a description of the components of the ES5372.1 Carrier Board. It also features instructions for the installation and information about the fuses.

Fig. 2-1 shows the ES5372.1 Carrier Board with front plate removed. The front plate is fastened to the card cage using four T8 TORX screws.

The installation instructions for installing ES445x.y Load Carrier Boards is located in chapter 2.3 on page 25

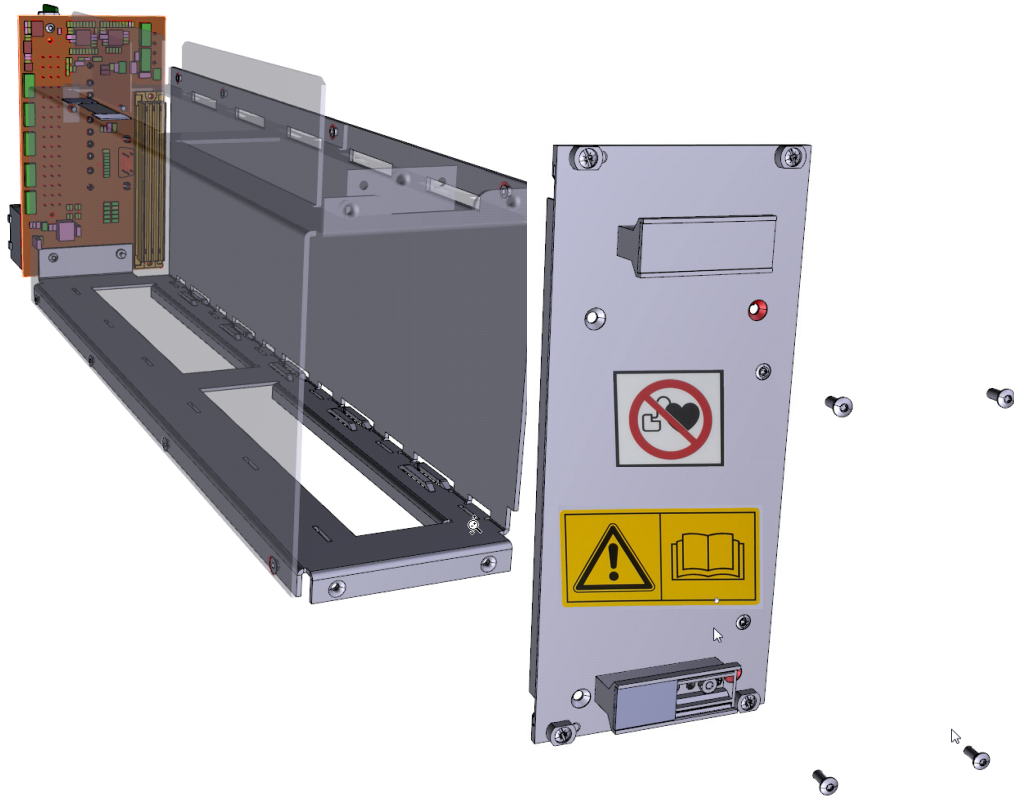

**Fig. 2-1** ES5372.1 Carrier Board

## 2.1 Position of Plug Connections

The ES5372.1 Carrier Board for ES4455 Load Boards features various connectors for internal and external connections. The positions of the connectors are shown in Fig. 2-2.

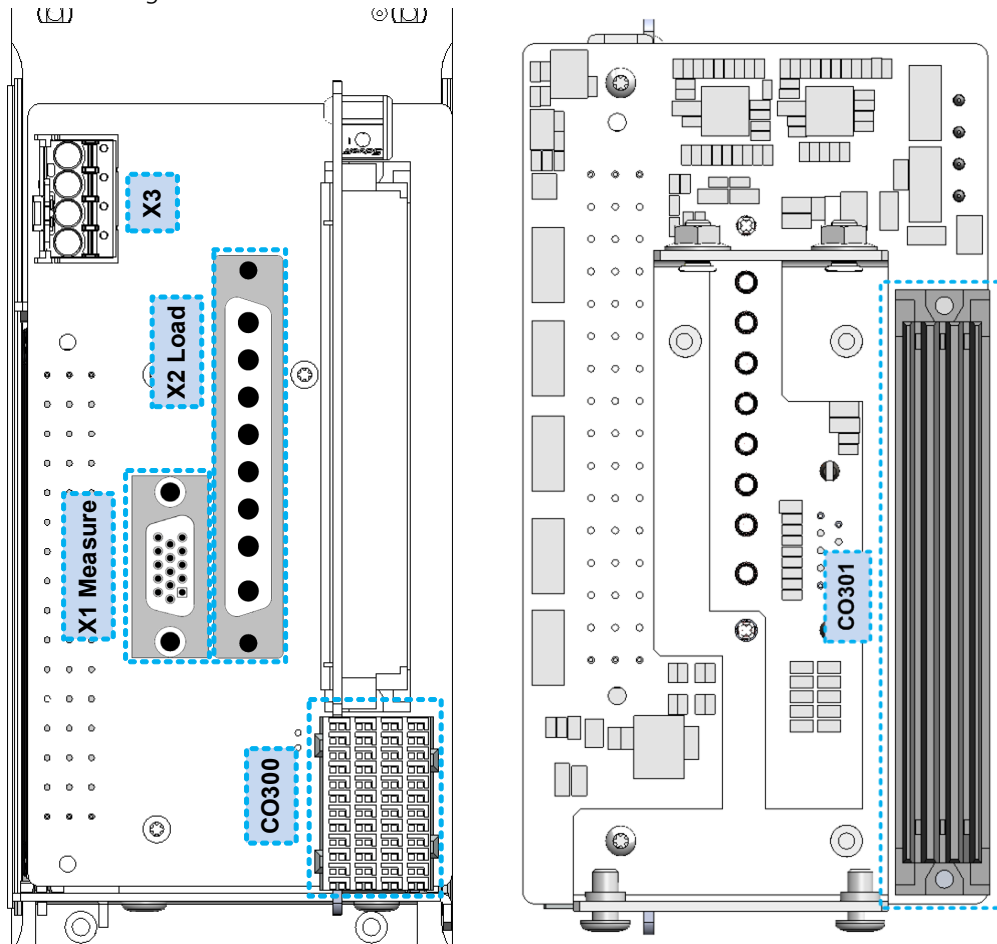

**Fig. 2-2** View of the backplane (left) and the rear side of the backplane (right) of the ES5372.1 Carrier Board

The ES5372.1 Carrier Board for ES4455 Load Boards and inserted Load Boards are supplied with voltage via the backplane of the ES5300.1-A Housing or the ES5300.1-B Housing. The electrical connection is done via plug connector CO300 (see Fig. 2-2).

CO301 is used to contact an ES445x.y Load Carrier Board from Tab. 1-1 on page 5.

The connections X1 Measure and X2 Load allow the connection to an ECU. The load channels of an ES445x.y Load Carrier Board with load module are located at the X2 Load connector. The X1 Measure plug can be used to measure the signals that represent the injection times (I\_Dig\_outx). The analog output for the Online\_probe is also at the X1 Measure connector.

For the pin assignment of the plug connections, see "Connections and Plug Connections" on page 33.

## 2.2 Fuses

---

The voltages of the backplane of the ES5300.1-A Housing or the ES5300.1-B Housing are protected with five fuses on the ES5372.1 Carrier Board. Two additional fuses FU300 and FU301 can be installed for protecting external battery voltages.

Fig. 2-3 on page 24 shows the position of the circuit board containing the fuses and the position of the fuses. Tab. 2-1 on page 24 lists the fuses with their specification.

In case of a fuse defect, we recommend sending the board to ETAS for further testing. For this purpose, the device should be sent to ETAS (see "ETAS Contact Addresses" on page 43).

If a fuse trips multiple times, the device must be sent to ETAS.

**WARNING!**

*Fire hazard!*

*Use only fuses that meet the specification in Tab. 2-1 on page 24!*

*Never bridge defective fuses!*

*Failure to observe the fuse specification can lead to excess currents, short circuits and fires.*

**CAUTION!**

*Replace fuses only with uninstalled ES5372.1 Carrier Board!*

*Observe "Installation / Removal of the ES5372.1 Carrier Board into/ from the ES5300.1-A Housing and ES5300.1-B Housing" on page 28*

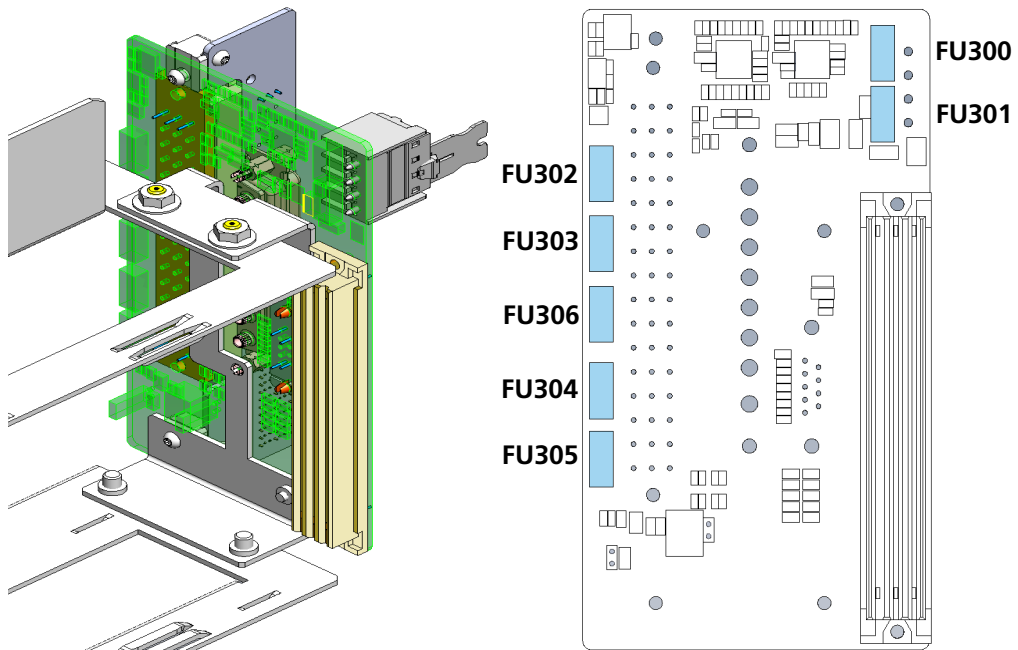

**Fig. 2-3** Position of the circuit board containing the fuses (marked in light green) and position of the fuses (marked in light blue)

Fuse	Type	Specification	Fuse protection of (voltage)
FU300	NANO2® Slo-Blo® Fuse 452/454 Series	T 5 A	+/- VBAT
FU301	NANO2® Slo-Blo® Fuse 452/454 Series	T 5 A	+/- VBAT
FU302	NANO2® Slo-Blo® Fuse 452/454 Series	T 1.5 A	+24 V
FU303	NANO2® Slo-Blo® Fuse 452/454 Series	T 3 A	VCC12 (+12 V)
FU306	NANO2® Slo-Blo® Fuse 452/454 Series	T 1.5 A	VSS12 (-12 V)
FU304	NANO2® Slo-Blo® Fuse 452/454 Series	T 3 A	VCC5 (+5 V)
FU305	NANO2® Slo-Blo® Fuse 452/454 Series	T 3 A	VCC3_3 (+3.3 V)

**Tab. 2-1** Specification of fuses on the ES5372.1 Carrier Board  
Position and specification of the fuses on the ES4455.2 plug-in cards are described in the ES4455.2 Users Guide.



## 2.3 Installation of an ES445x.y Load Carrier Board in an ES5372.1 Carrier Board

---

Below is the description of how to install the ES445x.y Load Carrier Board from Tab. 1-1 on page 5 in the ES5372.1 Carrier Board.

**WARNING!**

*The ES5372.1 Carrier Board for ES4455 Load Boards may be populated only with the plug-in cards listed in Tab. 1-1 on page 5. If other plug-in cards than those in Tab. 1-1 on page 5 are used, it can lead to damages to the ES5300.1-A Housing, ES5300.1-B Housing, the plug-in cards and/or damages to property and personal injury.*

**CAUTION!**

*Some components of the ES5372.1 Carrier Board and the plug-in cards listed in Tab. 1-1 on page 5 can be damaged or destroyed by electrostatic discharges. Leave the plug-in cards in their transport packaging until their installation.  
The ES5372.1 Carrier Board and the plug-in cards listed in Tab. 1-1 on page 5 should only be removed, configured and installed at a workplace that is secured against static discharges.*

### Installation of an ES445x.y Load Carrier Board in an ES5372.1 Carrier Board

The installation of an ES4452.1 Load Carrier Board is used as an example. The installation of other ES445x.y Load Carrier Boards is done in a similar way.

1. Ensure that ESD-compliant conditions exist at your workplace.
2. Loosen the two screws (Phillips PH1, marked in red in Fig. 2-4) with which the ES4452.1 front plate is fastened.

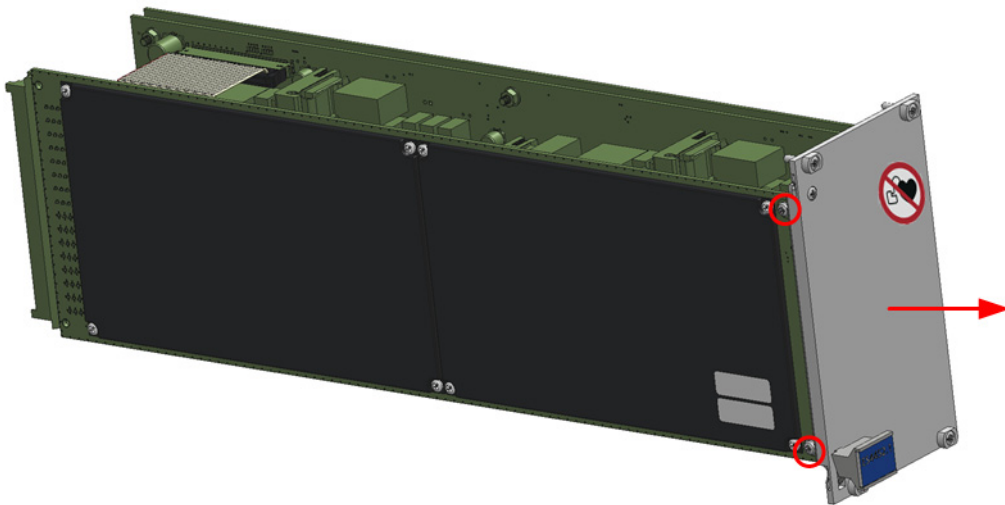

**Fig. 2-4** Loosening the screws and removing the ES4452.1 front plate

3. Remove the front plate in the direction of the arrow (Fig. 2-4 on page 26).
4. Set the small blue plate with the product labeling aside. It will be required in a later step at the lower handle of the ES5372.1.

#### **Note**

*Retain the screws and front plate if you want to retrofit the ES4452.1 again at a later time.  
If this is not the case, please ensure a correct separation of materials (see "Product Return and Recycling" on page 17).  
You will need the washers later to mount the ES5372.1 front plate (see Fig. 2-5)*

5. Use Fig. 2-5 accordingly and position the preassembled mounting brackets (framed in green) of the ES5372.1 front plate onto the ES4452.1 assembly holes (framed in red).

- Fix the ES5372.1 front plate onto the ES4452.1 with two of the supplied TORX screws and the available washers (see areas circled in red in Fig. 2-5)

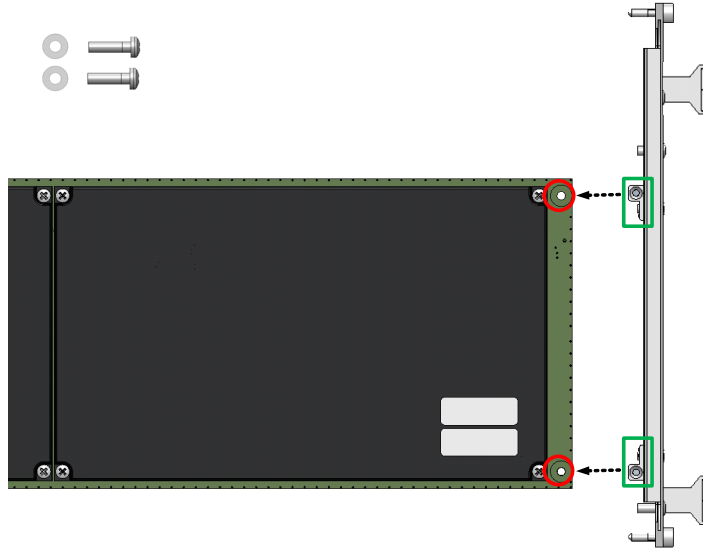

**Fig. 2-5** Installation of ES5372.1 front plate onto the ES4452.1

**Note**

Ensure that the components are subject to the least possible mechanical stress. Screws should be fastened finger-tight only (0.8 Nm).

- Carefully push the ES4452.1 with assembled ES5372.1 front plate into the ES5372.1 card cage (see Fig. 2-6)  
The guide rails are framed in green in Fig. 2-7.

**Note**

When installing in the ES5372.1 card cage, please ensure that the cards are correctly aligned so that no pins are bent at the connectors and that no increased mechanical tension occurs.

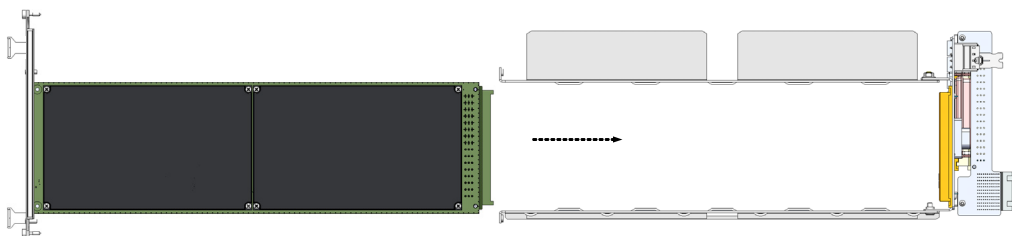

**Fig. 2-6** Installation of the ES4452.1 (left) with attached ES5372.1 front plate in ES5372.1 card cage (right)

8. Fasten the ES4452.1 with attached front plate of the ES5372.1 with four of the supplied TORX screws (T8) at the card cage (see Fig. 2-7, framed in red).

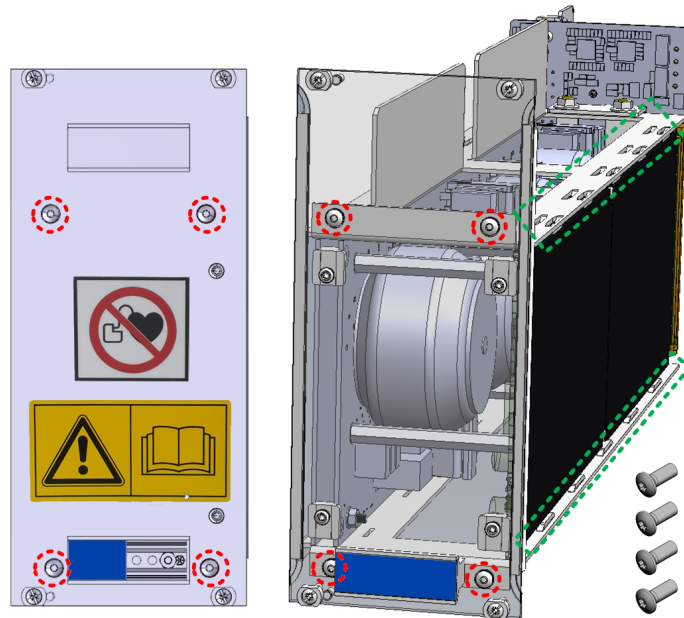

**Fig. 2-7** Fasten the ES445x.y with ES5372.1 front plate at the card cage of the ES5372 using four of the supplied TORX screws (T8). The front plate is shown transparent on the right.

9. Insert the small blue plate with the product labeling (e.g. ES4452.1) in the free slot of the ES5372.1 handle for product identification.

## 2.4 Installation / Removal of the ES5372.1 Carrier Board into/from the ES5300.1-A Housing and ES5300.1-B Housing

This chapter describes how the ES5372.1 Carrier Board for ES4455 Load Boards can be installed in or removed from the ES5300.1-A housing or the ES5300.1-B housing.



### **WARNING!**

*Danger through electromagnetic radiation!  
The ES5372.1 Carrier Board may emit electromagnetic radiation during operation which can interfere with the operation or cause damage to pacemakers and implanted defibrillators.  
The ES5372.1 Carrier Board may be operated only in areas to which persons with pacemakers have no access. The entrances to these areas must show the designation P007 "No access for persons with pacemakers or implanted defibrillators" in accordance with ISO 7010:2011 "Registered Safety Signs" and must be clearly visible. Failure to observe it can lead to health hazards and even death for persons with pacemakers and implanted defibrillators.*

**CAUTION!**

*Do not install any plug-in cards while the ES5300.1-A Housing and/or ES5300.1-B Housing is switched on. first, switch off the ES5300.1-A Housing and/or the ES5300.1-B Housing by shutting down the real-time PC and actuating the on/off switch on the rear side.*

**WARNING!**

*Danger of high voltages!  
The components, connectors, printed circuits and installed ES445x.y Load Carrier Boards of the ES5372.1 Carrier Board can carry dangerous voltages. These voltages can also be present when the ES5372.1 Carrier Board is not installed in the ES5300.1-A Housing or in the ES5300.1-B Housing or the ES5300.1-A Housing or ES5300.1-B Housing is switched off.  
Ensure that the ES5372.1 Carrier Board is protected against any contact during operation. Switch off the ES5300.1-A Housing or ES5300.1-B Housing and pull the power plug. Wait at least three minutes before uninstalling the ES5372.1 Carrier Board.*

**CAUTION!**

*Some components of the ES5372.1 Carrier Board for ES4455 Load Boards and the plug-in cards listed in Tab. 1-1 on page 5 can be damaged or destroyed by electrostatic discharges. Leave the plug-in cards in their transport packaging until their installation.  
The ES5372.1 Carrier Board for ES4455 Load Boards and the plug-in cards listed in Tab. 1-1 on page 5 should only be removed, configured and installed at a workplace that is secured against static discharges.*

**CAUTION!**

*During the installation and removal of the ES5372.1 Carrier Board into or from the ES5300.1-A Housing and the ES5300.1-B Housing, observe the following: Always guide the plug-in cards with both hands. The populated cards are heavy and may fall if carried with one hand only.*

**CAUTION!**

*The air circulation inside the ES5300.1-A Housing and the ES5300.1-B Housing can be ensured only if all free slots are covered with front plates. Otherwise, it may lead to overtemperatures and trip the overtemperature protection of the ES5300.1-A or ES5300.1-B. For this reason, install front plates in all free slots!*

**CAUTION!**

*If cards (e.g. for startup or calibration) are unlocked but not completely removed from the housing, they must be pulled out far enough that the distance between the respective card and the back-plane of the housing is at least 1 cm. Otherwise, contacts may be established between the cards and lead to their destruction.*

### Installation of the ES5372.1 Carrier Board in the ES5300.1-A Housing or ES5300.1-B Housing

---

1. Ensure that ESD-compliant conditions exist at your workplace.
2. Shut down the real-time PC and switch off the power supply of the ES5300.1-A or ES5300.1-B using the switch at the rear of the housing.
3. Wait at least three minutes for the components (capacitors, etc.) to be discharged.

**Note**

*Always hold and guide the plug-in cards with both hands. The populated cards are heavy and may fall if carried with one hand only.*

4. Insert the ES5372.1 Carrier Board (handle at the front plate must point down!) into the upper and lower rail of the slot and push it in a little bit.

**Note**

*If correctly installed, the ES5372.1 Carrier Board occupies three slots of the ES5300.1-A Housing or the ES5300.1-B Housing. If neighboring cards or cover slots collide with the ES5372.1, the combination of ES5372.1 and ES445x.y Load Carrier Board was not correctly installed. Observe "Installation of an ES445x.y Load Carrier Board in an ES5372.1 Carrier Board" on page 25*

5. Carefully push in the carrier board until the back-plane connector of the ES5372.1 is completely inserted in the socket of the backplane.

**Note**

*Watch for cables in the insertion area while pushing in the board – pull the lines to the front door area if necessary.*

6. Secure the carrier card by fastening the front plate with screws.
7. Install front plates in all open slots before placing the ES5372.1 Carrier Board in operation (see also safety notice "Caution" on page 29).

### Removal of the ES5372.1 Carrier Board from an ES5300.1-A Housing or ES5300.1-B Housing

---

1. Ensure that ESD-compliant conditions exist at your workplace.
2. Shut down the real-time PC and switch off the power supply of the ES5300.1-A or ES5300.1-B using the switch at the rear of the housing.
3. Wait at least three minutes for the components (capacitors, etc.) to be discharged (see also safety notice "Warning" on page 29).

**Note**

*Always hold and guide the plug-in cards with both hands. The populated cards are heavy and may fall if carried with one hand only.*

4. Loosen the screws on the front plate. Carefully guide the card out of the housing with both hands.





### 3 Connections and Plug Connections

This section provides a description of the different connections of the ES5372.1 Carrier Board.

- "Backplane Connector CO300" on page 33
- "X1 Measure and X2 Load Connectors" on page 35
- "CO301 Connector for ES445x.y Load Carrier Boards" on page 37
- "X3 Battery Voltage Connector" on page 38



**WARNING!**

*Fire hazard!*

*Use only approved cables for creating cable assemblies (e.g. for connecting the ECU and external loads). The cables used must be suitable particularly for occurring currents, voltages and temperatures and flame-retardant in accordance with one of the following standards IEC 60332-1-2, IEC 60332-2-2, UL 2556/UL1581VW-1!*

#### 3.1 Backplane Connector CO300

The backplane connector CO300 forms the communication interface to the ES5300.1-A Housing and to the ES5300.1-B Housing. The CO300 also handles the voltage supply for the ES5372.1 Carrier Board.

**Type:** ERNI ERMet ZD 4-pair angled female multipoint connector (4-12) (order no. 973099)

**Counterplug (in ES5300):** ERNI ERMet ZD -pair straight male multipoint connector (4-12) (order no. 973096)

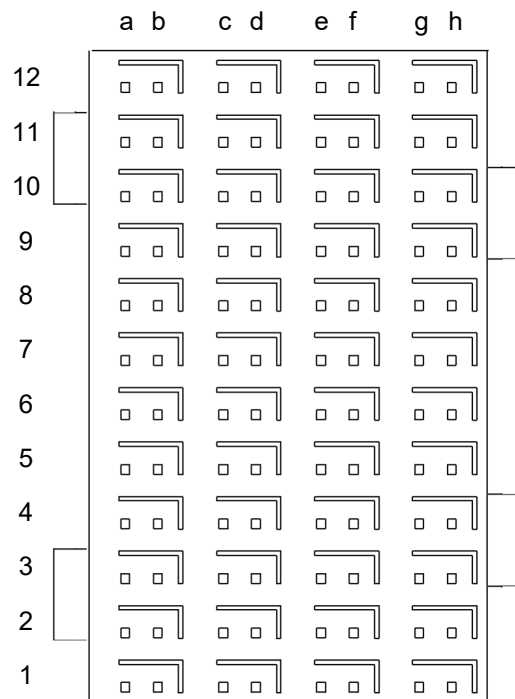

**Fig. 3-1** CO300 connector to backplane (top view)

The assignment of the pins is as follows (the maximum possible pin assignment for the ES5300.1-A Housing and the ES5300.1-B Housing i):

	<b>h</b>	<b>g</b>	<b>f</b>	<b>e</b>	<b>d</b>	<b>c</b>	<b>e</b>	<b>a</b>
<b>12</b>	GBLI_TX_n_0	GBLI_TX_p_0	GBLI_RX_n_0	GBLI_RX_p_0	M_LVDS_n_7	M_LVDS_p_7	BN_5	BN_4
<b>12-shield</b>	GND		GND		GND		GND	
<b>11</b>	GBLI_TX_n_1	GBLI_TX_p_1	GBLI_RX_n_1	GBLI_RX_p_1	M_LVDS_n_6	M_LVDS_p_6	SPI_CS_B_n	SPI_CS_A_n
<b>11-shield</b>	GND		GND		GND		GND	
<b>10</b>	GBLI_TX_n_2	GBLI_TX_p_2	GBLI_RX_n_2	GBLI_RX_p_2	M_LVDS_n_5	M_LVDS_p_5	SPI_MOSI	SPI_CLK
<b>10-shield</b>	GND		GND		GND		GND	
<b>9</b>	GBLI_TX_n_3	GBLI_TX_p_3	GBLI_RX_n_3	GBLI_RX_p_3	M_LVDS_n_4	M_LVDS_p_4	PCIE_WAKE_n	SPI_MISO
<b>9-shield</b>	GND		GND		GND		GND	
<b>8</b>	GBLI_PRESENT_n	GEO_ADDR_4	PCIE_REFCLK_n	PCIE_REFCLK_p	M_LVDS_n_3	M_LVDS_p_3	n.c.	n.c.
<b>8-shield</b>	GND		GND		GND		GND	
<b>7</b>	PCIE_RX_n_0	PCIE_RX_p_0	PCIE_TX_n_0	PCIE_TX_p_0	M_LVDS_n_2	M_LVDS_p_2	n.c.	n.c.
<b>7-shield</b>	GND		GND		GND		GND	
<b>6</b>	Ass. internally	Ass. internally	Ass. internally	Ass. internally	M_LVDS_n_1	M_LVDS_p_1	PCIE_JTAG_TCK	PCIE_JTAG_TDI
<b>6-shield</b>	GND		GND		GND		GND	
<b>5</b>	Ass. internally	Ass. internally	Ass. internally	Ass. internally	M_LVDS_n_0	M_LVDS_p_0	PCIE_JTAG_TDO	PCIE_JTAG_TMS
<b>5-shield</b>	GND		GND		GND		GND	
<b>4</b>	Ass. internally	Ass. internally	Ass. internally	Ass. internally	GEO_ADDR_1	GEO_ADDR_0	BN_3	BN_2
<b>4-shield</b>	GND		GND		GND		GND	
<b>3</b>	VCC24	VCC24	GEO_ADDR_3	GEO_ADDR_2	PCIE_SMBDAT	PCIE_SMBCLK	BN_1	BN_0
<b>3-shield</b>	VCC3_3		VCC3_3		VCC3_3		VCC3_3	
<b>2</b>	VSS12	VSS12	VCC3_3	VCC5	PCIE_PERSTn	PCIE_PRSTn	PCIE_PRSTn_X 1	PCIE_PRSTn_X 4
<b>2-shield</b>	VCC12		VCC12		VCC12		VCC12	
<b>1</b>	VCC3_3	VCC3_3	VCC5	VCC5	VCC12	VCC12	VCC12	VCC12
<b>1-shield</b>	VCC12		VCC12		VCC12		VCC12	

### 3.2 X1 Measure and X2 Load Connectors

The connectors X1 Measure and X2 Load allow connecting the ES5372.1 Carrier Board to an ECU. Fig. 3-2

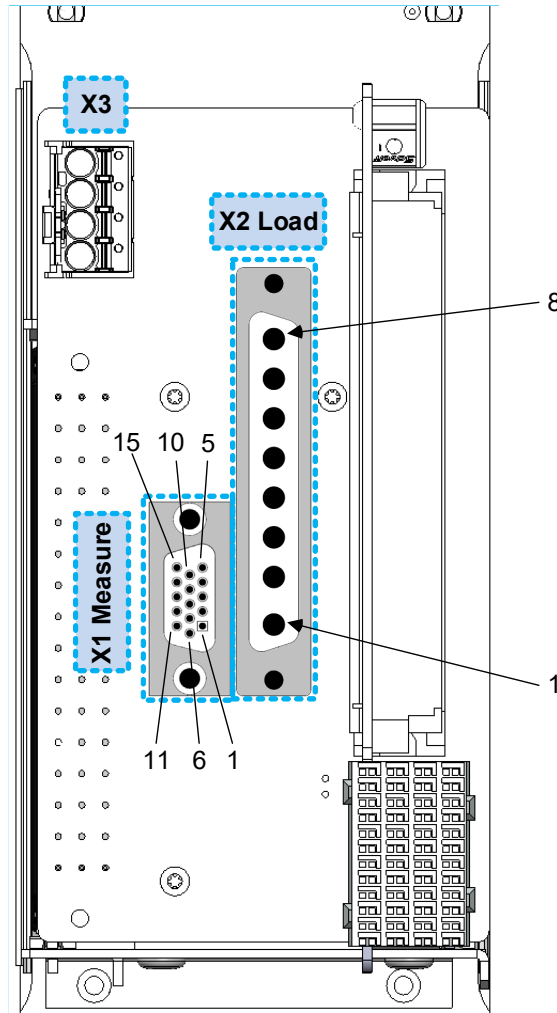

**Fig. 3-2** Pin numbering of connectors X1 Measure and X2 Load

The pin assignment for the connectors X1 Measure and X2 Load are specified in Tab. 3-1 on page 36 and in Tab. 3-2 on page 36.

For a more detailed description of the functions of the installed ES445x.y Load Carrier Board, please read the ES4455.2 User's Guide or contact the Technical Support (see "ETAS Contact Addresses" on page 43).

### 3.2.1 X2 Load Plug Connector

---

Type: Hybrid-DSUB FM8W8P-5852 (male)

Manufacturer: FCT

Counterplug: Hybrid-DSUB 8W8 (female)

The pin assignment of X2 Load is as follows:

Pin	Signal
A1	Load 1+
A2	Load 1–
A3	Load 2+
A4	Load 2–
A5	Load 3+
A6	Load 3–
A7	Load 4+
A8	Load 4–
Housing	

**Tab. 3-1** Pin assignment of X2 Load

### 3.2.2 X1 Measure Connector

---

Type: HD15-pin (female)

Counterplug: HD15-pin (male)

The pin assignment of X1 Measure is as follows:

Connection:Pin	Signal Name
Meas 1	I_Dig_Out_1
Meas 2	I_Dig_Out_2
Meas 3	I_Dig_Out_3
Meas 4	I_Dig_Out_4
Meas 5	Online_Probe
Meas 6	Online_Probe_Ref
Meas 7	not used
Meas 8	not used
Meas 9 - 15	GND
Housing	

**Tab. 3-2** Pin assignment of X1 Measure

### 3.3 CO301 Connector for ES445x.y Load Carrier Boards

The CO301 connector is the electrical interface between ES5372.1 Carrier Board and ES445x.y Load Carrier Boards from Tab. 1-1 on page 5.

The pin assignment of CO301 is described in Fig. 3-3 on page 37 and Tab. 3-3 on page 37.

Type: DIN41612\_Type\_F\_MALE

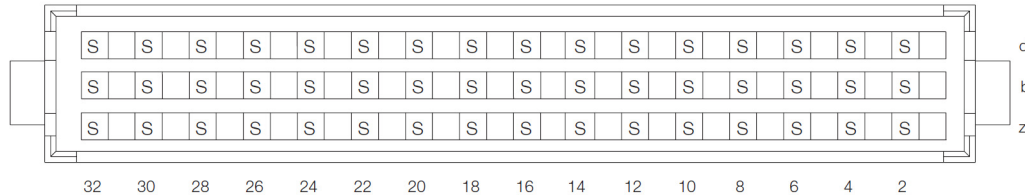

**Fig. 3-3** CO301 connector

The pin assignment for the CO301 connector is as follows:.

Pin	Signal	Pin	Signal	Pin	Signal
z2	+12VUF	b2	GND	d2	n.c.
z4	+5VUF	b4	not connected	d4	+3_3VUF
z6	SPI_GTL_MISO	b6	SPI_GTL_MOSI	d6	SPI_GTL_CLK_R
z8	nCS0	b8	JTAG_TDI_CON	d8	JTAG_TDO_CON
z10	JTAG_TCK_CON_R	b10	JTAG_TMS_CON	d10	I_Dig_Out_1
z12	I_Dig_Out_2	b12	I_Dig_Out_3	d12	I_Dig_Out_4
z14	Online_Probe	b14	Online_Probe_GND	d14	n.c.
z16	n.c.	b16	I_Dig_Out_x_GND	d16	-UBAT_R
z18	Load 1+	b18	Load 1+	d18	Load 1+
z20	Load 1-	b20	Load 1-	d20	Load 1-
z22	Load 2+	b22	Load 2+	d22	Load 2+
z24	Load 2-	b24	Load 2-	d24	Load 2-
z26	Load 3+	b26	Load 3+	d26	Load 3+
z28	Load 3-	b28	Load 3-	d28	Load 3-
z30	Load 4+	b30	Load 4+	d30	Load 4+
z32	Load 4-	b32	Load 4-	d32	Load 4-

**Tab. 3-3** CO301 pin assignment



**WARNING!**

The CO301 connector is approved only as interface for the ES445x.y Load Carrier Board from Tab. 1-1 on page 5. If other plug-in cards than those in Tab. 1-1 on page 5 are used, it can lead to damages to the ES5300.1-A Housing, ES5300.1-B Housing, the plug-in cards and/or damages to property and personal injury.

### 3.4 X3 Battery Voltage Connector

#### **Note**

*X3 must not be used for the following load boards: ES4450.3, ES4451.4, ES4452.1, ES4457.1*

#### **Pin header row (on the board):**

Type: WAGO picoMAX® (Prod. nr. 2092-1424)

#### **Multipoint connector (within scope of delivery):**

Type: WAGO picoMAX® (Prod. nr. 2092-1104)

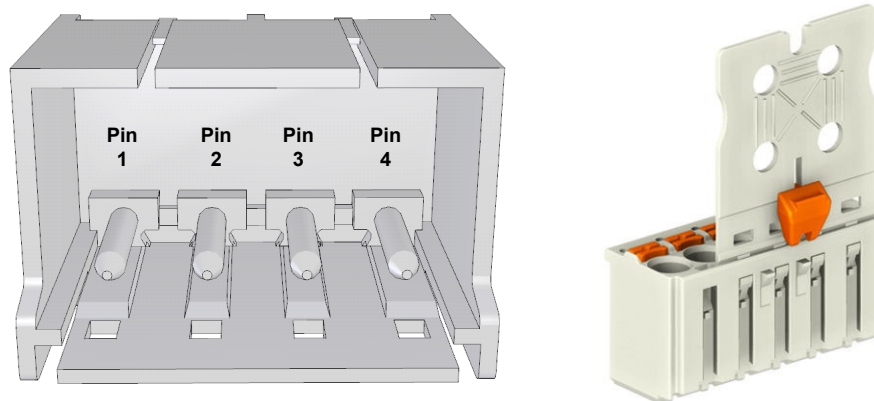

**Fig. 3-4** Pin header row X3 on the ES5372.1 Carrier Board (left) and multipoint connector with handle (right)

Pin	Signal
1	-UBat
2	-UBat
3	+UBat
4	+UBat

**Tab. 3-4** Pin assignment X3

The multipoint connector is specified for wire cross-sections from 0.2 mm<sup>2</sup> to 2.5 mm<sup>2</sup>. Flexible or rigid wires with or without wire end ferrules can be used. Observe the mounting recommendation of the manufacturer WAGO.

#### **Note**

*When disconnecting the multipoint connector, press the orange plate in the direction of the pin header row first.*

## 4 Technical Data and Standards

This chapter contains the technical data of the ES5372.1 Carrier Board for ES4455 Load Boards and the valid standards.

### 4.1 Technical Data

#### Load Channels Load 1 to Load 4

The following values apply to the X2 Load connector ("Load x +" to "Load x -") of the ES5372.1 Carrier Board.

Number	4
Abs. max. load current	+/- 20 A for max. 1 ms
Abs. max. load voltage per channel	+/- 60 V DC for max. 1 ms
Abs. max. duty cycle	25%
Max. power	50 W rms (root mean square)



#### CAUTION!

*The abs. max. load current, abs. max. load voltage, abs. max. duty cycle and maximum permissible power of 50 W rms must not be exceeded. If one or several of these values are exceeded, the injector load can be damaged, or an undefined behavior can occur (e.g. emergency shutdown of injector load).*

#### Measuring Channels Meas 1 to Meas 4

The following values apply to the X1 Measure connector of the ES5372.1 Carrier Board

Accuracy of current measurement - Level	±3%
Accuracy of current measurement - Timing	±2%
Electric strength of outputs	±60 V DC
Current rating of the connections	1 A (60 V DC) per pin

#### Connector X3 Battery Voltage

Maximum input voltage	±60 V DC
Maximum current per pin	2.5 A
Maximum total current	5 A

*Storage Conditions*

Temperature	-20 °C to 85 °C (-4 °F to 185 °F)
Relative humidity	0 to 95% (non-condensing)

*Ambient Conditions*

Environment	Use only inside enclosed and dry rooms
Max. contamination level	2
Temperature during operation	5 °C to 40 °C (41 °F to 104 °F)
Relative humidity	0 to 95% (non-condensing)
Operating altitude	Max. 2000 m above sea level

*Physical Dimensions ES5372.1 Carrier Board*

Height	3 U
Width	14 HP
Depth	340 mm
Weight	1.5 kg

4.2 Standards Met

The ES5372.1 Carrier Board meets the following standards:

Standard	Test
IEC 61326-1	Electrical equipment for measurement, control and laboratory use – EMC requirements (industrial setting)
IEC 61010-1	Safety requirements for electrical equipment for measurement, control and laboratory use - Part 1: General requirements

The board is only designed for use in industrial settings in accordance with EN 61326-1. Avoid potential radio interference when using the module outside of the industrial settings with additional shielding measures!



**WARNING!**

*This is class A equipment. This equipment can cause radio interference in residential areas. In this case, the operator may be required to institute reasonable measures.*

**Note**

*The signal lines may not exceed a maximum length of 3 m!*



## 5 **Ordering Data**

The ordering data for the ES5372.1 Carrier Board are as follows:

<b>Order name</b>	<b>Short name</b>	<b>Order number</b>
ES5372.1 Carrier Board for ES4455 Load Boards	ES5372.1	F-00K-109-682
<b>Scope of delivery</b>	<b>number of pieces</b>	
ES5372.1 Carrier Board for ES4455 Load Boards	1	
Multipoint connector Type: WAGO picoMAX® Prod. nr. 2092-1104	1	
TORX screws T8	6 + 1 spare part	



## 6 **ETAS Contact Addresses**

---

### *ETAS HQ*

---

ETAS GmbH

Borsigstraße 24

70469 Stuttgart

Germany

Phone: +49 711 3423-0

Fax: +49 711 3423-2106

WWW: [www.etas.com](http://www.etas.com)

### *ETAS Subsidiaries and Technical Support*

---

For details of your local sales office as well as your local technical support team and product hotlines, take a look at the ETAS website:

ETAS subsidiaries WWW: [www.etas.com/en/contact.php](http://www.etas.com/en/contact.php)

ETAS technical support WWW: [www.etas.com/en/hotlines.php](http://www.etas.com/en/hotlines.php)



---

## Index

**A**

Accident prevention 10  
Application areas 5

**B**

Basic safety notices 9

**C**

CE Declaration of Conformity 16  
Connecting devices 14  
Connections and Connectors 33  
    Backplane connector CO300 33  
    CO301 37  
    X1 Measure 35  
    X2 Load 35

**D**

Defibrillators 15  
Devices  
    Connecting 14

**E**

Electrical safety 11  
ETAS Contact Addresses 43

**F**

Fuses 21, 23

**G**

General safety information 9

**I**

Identification of safety notices 9  
Identifications on the product 15  
Improper use 9  
Installation 21, 26  
Intended use 11

**K**

KC Mark 16

**O**

Ordering data 41

**P**

Pacemaker 15  
Product return 17

**Q**

Qualification, required 9

**R**

Recycling 17  
Removal 31  
RoHS conformity  
    China 16  
    European Union 16

**S**

Safety at work 10, 11  
Safety precautions 9

Signal lines 40  
Standards 39, 40  
Storage conditions 40

**T**

Technical data 39

**W**

Waste Electrical and Electronic Equip-  
ment 17  
WEEE return system 17