



DRIVING EMBEDDED EXCELLENCE

ETAS ES410.1  
A/D Module  
User Guide

## Copyright

---

The data in this document may not be altered or amended without special notification from ETAS GmbH. ETAS GmbH undertakes no further obligation in relation to this document. The software described in it can only be used if the customer is in possession of a general license agreement or single license. Using and copying is only allowed in concurrence with the specifications stipulated in the contract.

Under no circumstances may any part of this document be copied, reproduced, transmitted, stored in a retrieval system or translated into another language without the express written permission of ETAS GmbH.

© **Copyright 2021** ETAS GmbH, Stuttgart

The names and designations used in this document are trademarks or brands belonging to the respective owners.

ES410.1 - User Guide R09 EN - 07.2021

# Contents

<b>1</b>	<b>About this Document</b> .....	<b>7</b>
1.1	Classification of Safety Messages .....	7
1.2	Presentation of Instructions .....	7
1.3	Presentation of Supporting Information .....	7
<b>2</b>	<b>Basic Safety Notices</b> .....	<b>8</b>
2.1	General Safety Information .....	8
2.2	Requirements for Users and Duties for Operators .....	8
2.3	Intended Use .....	8
<b>3</b>	<b>ES400 Product Family</b> .....	<b>13</b>
3.1	Wiring Concepts in Test Vehicles .....	13
3.2	Features of the ES400 Line .....	14
3.2.1	Advantages of the Decentral Wiring Concept .....	14
3.2.2	Further Features .....	14
3.3	Housing .....	15
3.4	Ports .....	15
3.4.1	"Sensor" Port .....	16
3.4.2	Daisy Chain Ports ("IN", "OUT") .....	16
3.5	LED .....	16
3.5.1	Operational State .....	16
3.5.2	Service State .....	17
3.5.3	Functional State .....	17
<b>4</b>	<b>Hardware Description</b> .....	<b>18</b>
4.1	Features of the ES410.1 .....	18
4.2	Block Diagram .....	19
4.3	Measurement Channels .....	19
4.3.1	Signal Processing and Filters .....	20
4.3.2	Galvanically Isolation .....	22
4.3.3	Maximum Input and Common-Mode Voltages .....	22
4.4	Data Transfer .....	23
4.4.1	Communication Protocols .....	23
4.4.2	Realization .....	24
4.4.3	Examples .....	26
4.5	Power Supply .....	28
4.5.1	Supply Voltage .....	28
4.5.2	Supplying the ES400 Modules via the Connecting Line .....	28
4.5.3	Additional Supply of the ES400 Modules via a Y-Boost Cable .....	28
4.6	Configuration .....	31
4.7	Tool Integration .....	31
4.8	Firmware Update .....	31
4.9	Calibration .....	31

<b>5</b>	<b>Getting Started</b>	<b>32</b>
5.1	General Installation Recommendations	32
5.1.1	Assembly Environment and Components for Attaching the Module	32
5.1.2	Potential Equalization in the Vehicle and Mounting the Modules	32
5.1.3	Guarantee of Features as defined by IP67	33
5.2	Assembly	33
5.2.1	How to Connect and Attach ES400 Modules	33
5.2.2	Connecting Several ES400 Modules Mechanically	34
5.2.3	Attaching ES400 Modules to Other Components Using the Integrated Assembly Elements	37
5.2.4	Attaching ES400 Modules on DIN Rails with the Integrated Assembly Elements	39
5.2.5	Attaching ES400 Modules to Other Components with Screws	41
5.2.6	Attaching ES400 Modules on DIN Rails using Screws	43
5.2.7	Attaching ES400 Modules to Other Components Using Cable Fasteners	45
5.3	Drilling Template	47
5.4	Applications	48
5.4.1	General	48
5.4.2	ES410.1 with additional ETAS Modules (MC Application)	48
5.4.3	ES410.1 with additional ETAS Modules (Rapid Prototyping Application)	49
5.5	Wiring Examples	50
5.5.1	ES400 Modules with additional ETAS Modules (Measurement and Calibration)	50
5.5.2	ES400 Modules with additional ETAS Modules and Drive Recorder (Measurement and Calibration)	51
5.5.3	ES400 Modules with ES910.3 (Rapid Prototyping)	52
5.5.4	ES400 Modules with ES910.3 and Drive Recorder (Rapid Prototyping)	53
5.5.5	ES400 Modules with ETAS RTPRO-PC (Rapid Prototyping)	54
5.6	Wiring	55
5.6.1	"Sensor" Port	55
5.6.2	Daisy Chain Ports ("IN", "OUT")	55
<b>6</b>	<b>Troubleshooting Problems</b>	<b>57</b>
6.1	LED Displays	57
6.2	Troubleshooting ES410.1 Problems	57
6.3	Problems and Solutions	59
6.3.1	Network Adapter Cannot Be Selected via Network Manager	59
6.3.2	Search for Ethernet Hardware Fails	60
6.3.3	Personal Firewall Blocks Communication	62
<b>7</b>	<b>Technical Data</b>	<b>65</b>
7.1	General Data	65
7.1.1	Product Labeling	65
7.1.2	Standards and Norms	66
7.1.3	Environmental Conditions	67
7.1.4	Maintenance the Product	67
7.1.5	Cleaning the Product	68
7.1.6	Mechanical Data	68
7.1.7	Modules in One Chain	68
7.2	RoHS Conformity	68
7.3	CE conformity	68

7.4	UKCA conformity .....	68
7.5	KCC conformity .....	68
7.6	Product Return and Recycling .....	69
7.7	Declarable Substances .....	69
7.8	Use of Open Source Software .....	69
7.9	System Requirements .....	70
7.9.1	Hardware .....	70
7.9.2	Software .....	70
7.10	Electrical Data .....	71
7.10.1	Host Interface .....	71
7.10.2	Power Supply .....	72
7.10.3	Sensor Inputs .....	72
7.10.4	Signal Processing .....	74
7.11	Pin Assignment .....	75
7.11.1	"IN" Connector .....	75
7.11.2	"OUT" Connector .....	76
7.11.3	"Sensor" Connector .....	77
<b>8</b>	<b>Cables and Accessories .....</b>	<b>78</b>
8.1	Combined Ethernet and Power Supply Cable .....	79
8.1.1	Overview .....	79
8.1.2	CBEP410.1 Cable .....	80
8.1.3	CBEP4105.1 Cable .....	80
8.1.4	CBEP415.1 Cable .....	81
8.1.5	CBEP4155.1 Cable .....	81
8.1.6	CBEP420.1 Cable .....	82
8.1.7	CBEP4205.1 Cable .....	82
8.1.8	CBEP425.1 Cable .....	83
8.1.9	CBEP4255.1 Cable .....	83
8.1.10	CBEP430.1 Cable .....	84
8.1.11	CBEP4305.1 Cable .....	84
8.2	Ethernet Cable .....	85
8.2.1	CBE400.2 Cable .....	85
8.2.2	CBE401.1 Cable .....	85
8.2.3	CBE430.1 Cable .....	86
8.2.4	CBE431.1 Cable .....	86
8.2.5	CBEX400.1 Cable .....	86
8.2.6	ES4xx_BRIDGE .....	87
8.3	Cables for the Connector "Sensor" .....	88
8.3.1	CBAV401.1 Cable .....	88
8.3.2	CBAV403.1 Cable .....	89
8.3.3	CBAV480.1 Cable .....	90
8.4	Protective Caps .....	91
8.4.1	Protective Caps supplied .....	91
8.4.2	Cap CAP_LEMO_1B .....	91
8.4.3	Cap CAP_LEMO_1B_LC .....	91
8.4.4	Cap CAP_SOURIAU_8STA .....	91
8.5	Angle Brackets .....	92
8.5.1	Angle Bracket Left .....	92
8.5.2	Angle Bracket Right .....	92

<b>9</b>	<b>Ordering Information</b> .....	<b>93</b>
9.1	ES410.1 .....	93
9.2	Accessories .....	93
9.2.1	Cables .....	93
9.2.2	Protective Caps .....	95
9.2.3	Angle Brackets .....	95
9.2.4	Calibration .....	95
<b>10</b>	<b>Contact Information</b> .....	<b>97</b>
	<b>Figures</b> .....	<b>98</b>
	<b>Index</b> .....	<b>100</b>

# 1 About this Document

---

## 1.1 Classification of Safety Messages

---

The safety messages used here warn of dangers that can lead to personal injury or damage to property:



### **DANGER**

---

indicates a hazardous situation with a high risk of death or serious injury if not avoided.



### **WARNING**

---

indicates a hazardous situation of medium risk, which could result in death or serious injury if not avoided.



### **CAUTION**

---

indicates a hazardous situation of low risk, which may result in minor or moderate injury if not avoided.

### **NOTICE**

---

indicates a situation, which may result in damage to property if not avoided.

## 1.2 Presentation of Instructions

---

The target to be achieved is defined in the heading. The necessary steps for his are in a step-by-step guide:

#### Target definition

1. Step 1
2. Step 2
3. Step 3
- > Result

## 1.3 Presentation of Supporting Information

---



### **NOTE**

---

Contains additional supporting information.

## 2 Basic Safety Notices

---

This chapter contains information about the following topics:

- "General Safety Information" on page 8
- "Requirements for Users and Duties for Operators" on page 8
- "Intended Use" on page 8

### 2.1 General Safety Information

---

Please observe the Product Safety Notices ("ETAS Safety Notice") and the following safety notices to avoid health issues or damage to the device.



#### **NOTE**

Carefully read the documentation (Product Safety Advice and this User's Guide) that belongs to the product prior to the startup.

ETAS GmbH does not assume any liability for damages resulting from improper handling, unintended use or non-observance of the safety precautions.

### 2.2 Requirements for Users and Duties for Operators

---

The product may be assembled, operated and maintained only if you have the necessary qualification and experience for this product. Incorrect operation or operation by users without sufficient qualification may lead to injuries or death or property damages.

The safety of systems that are using the product is the responsibility of the system integrator.

#### **General safety at work**

The existing regulations for safety at work and accident prevention must be followed. All applicable regulations and statutes regarding operation must be strictly followed when using this product.

### 2.3 Intended Use

---

#### **Application area of the product**

This product was developed and approved for applications in the automotive area. The module is suitable for use in interiors, in the passenger cell, in the trunk, in the engine compartment or in the exterior area of vehicles.

For use in other application areas, please contact your ETAS contact partner.



### **Requirements for the technical state of the product**

The product is designed in accordance with state-of-the-art technology and recognized safety rules. The product may be operated only in a technically flawless condition and according to the intended purpose and with regard to safety and dangers as stated in the respective product documentation. If the product is not used according to its intended purpose, the protection of the product may be impaired.

### **Requirements for operation**

- Use the product only according to the specifications in the corresponding User's Guide. With any deviating operation, the product safety is no longer ensured.
- Observe the requirements on the ambient conditions.
- Do not use the product in potentially explosive atmospheres.

### **Electrical safety and power supply**

- Observe the regulations applicable at the operating location concerning electrical safety as well as the laws and regulations concerning work safety!
- Connect only current circuits with safety extra-low voltage in accordance with EN 61140 (degree of protection III) to the connections of the module.
- Ensure the compliance with the connection and adjustment values (see the information in the chapter "Technical Data").
- Do not apply any voltages to the connections of the module that do not correspond to the specifications of the respective connection.

### **Power supply**

- The power supply for the product must be safely disconnected from the supply voltage. For example, use a car battery or a suitable lab power supply.
- Use exclusively lab power supplies with double protection to the supply system (with double insulation / with reinforced insulation (DI/ RI)).
- The lab power supply must be approved for an operating altitude of 5,000 m and for an ambient temperature of up to 120 °C.
- For normal operation of the modules as well as for very long standby operation, it is possible that the vehicle battery will be drained.

### **Connection to the power supply**

- The power cable may not be connected directly to the vehicle battery or the lab power supply, but only via a suitable fuse.
- Ensure that the connections of the lab power supply, the power supply at the module and the vehicle battery are easily accessible!
- Route the power cable in such a way that it is protected against abrasion, damages, deformation and kinking. Do not place any objects on the power cable!



## **DANGER**

### **Dangerous electrical voltage!**

Connect the power cable only with a suitable vehicle battery or with a suitable lab power supply! The connection to power outlets is not allowed!

To prevent an inadvertent insertion in power outlets, ETAS recommends to equip the power cables with safety banana plugs in areas with power outlets.

## **De-energizing the module**

The module does not have an operating voltage switch. The module can be de-energized as follows:

- Disconnecting the cables from the measurement inputs  
*and*
- Disconnecting the module from the power supply
  - Switching off the lab power supply  
*or*
  - Disconnecting the module from the lab power supply  
Separating device is the lab plug of the power cable or the plug of the power cable at the connection of the module  
*or*
  - Disconnecting the module from the vehicle battery  
Separating device is the lab plug of the power cable or the plug of the power cable at the connection of the module  
*or*
  - Disconnecting the vehicle battery.

## **Cabling**

Approved cables:

- Use exclusively ETAS cables at the connections of the module!
- Adhere to the maximum permissible cable lengths!
- Do not use any damaged cables! Cables may be repaired only by ETAS!



## **CAUTION**

### **Never apply force to insert a plug into a socket.**

Ensure that there is no contamination in and on the connection, that the plug fits the socket, and that you correctly aligned the plugs with the connection.



## **CAUTION**

### **Damage possible to connectors of the modules or the ES4xx\_BRIDGE!**

Fasten the two modules with screws to the stop inside the module without canting them.

For detailed information about cabling, see the User's Guide of the module.



### **CAUTION**

#### **Potential equalization in the vehicle is possible via the shield of the connecting cables of the modules!**

Install the modules only at locations with the same electrical potential or isolate the modules from the installation location.

### **Requirements for the place of installation**

- Place the module or the module block on a smooth, even and firm foundation.
- The module or module block must always be securely fastened.

### **Requirements on the ventilation**

- Keep the module away from heat sources and protect it against direct exposure to the sun.
- The free space above and behind the module must be selected so that sufficient air circulation is ensured.

### **Fixing the module on a carrier system**

When selecting the carrier system, observe the static and dynamic forces that could be created by the module or the module block at the carrier system.



### **CAUTION**

#### **Damage or destruction of the module is possible.**

The modules of series ES400 are approved only for installation and operation at components or locations that ensure compliance with the technical data of the modules, such as:

- the resistance to vibration of the modules (for example, install modules only on spring-loaded bodies, not on wheel suspensions or directly at the motor) and
- the temperature resistance of the modules (for example, do not install modules on the motor, turbocharger, exhaust manifold or their environments).



### **CAUTION**

During the installation of the modules, observe the permissible temperature range of the cable ties being used!

## Damage of the module and loss of properties acc. to IP67



### **CAUTION**

#### **Loss of Features as defined by IP67!**

Water standing at the pressure balance element damages the membrane!  
Please observe which way the module is pointing when installing vertically!

### **Transport**

- Mount and connect the modules only at the location of their startup!
- Do not transport the modules at the cable of the module or any other cables.

### **Maintenance**

The product is maintenance-free.

### **Repair**

If a repair of an ETAS hardware product should become necessary, send the product to ETAS.

### **Cleaning the module housing**

- Use a dry or lightly moistened, soft, lint-free cloth for cleaning the module housing.
- Do not use any sprays, solvents or abrasive cleaners which could damage the housing.
- Ensure that no moisture enters the housing. Never spray cleaning agents directly onto the module.

## 3 ES400 Product Family

---

This chapter contains information on the following topics:

- "Wiring Concepts in Test Vehicles" on page 13
- "Features of the ES400 Line" on page 14
- "Housing" on page 15
- "Ports" on page 15
- "LED" on page 16

### 3.1 Wiring Concepts in Test Vehicles

---

For the test phase, several hundred sensors must be installed in a test vehicle in various areas, e.g. in the engine compartment and in the floor area. The sensors, which are positioned all over the vehicle, then have to be connected to the measuring instruments of the test setup.

Today's standard solutions with their central setup of measuring instruments inside the vehicle require complex cabling to connect the widely distributed sensors with the measuring instruments. Numerous, usually long connection cables between the sensors and the measuring instruments, bundled together to form several fat wiring harnesses, require a highly modified splash wall of the test vehicle. This involves long setting-up times as well as high costs.

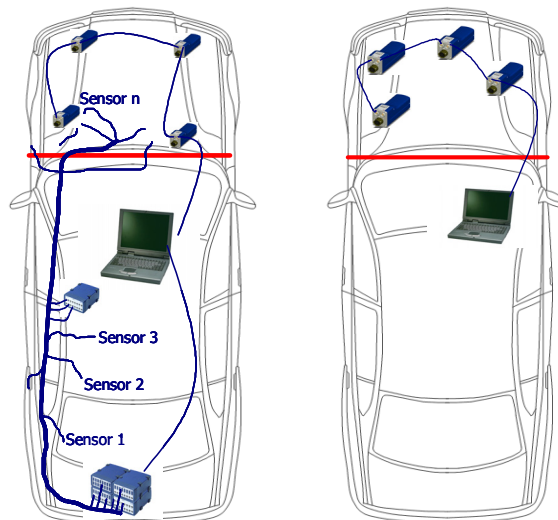

**Fig. 3-1** Central and Decentral Sensor Cabling

With the ES400 modules, ETAS provides a decentral solution which considerably simplifies the test setup of the sensors.

The basic idea of this concept is to install the modules of the ES400 family as close as possible to the sensors, to concatenate the modules with each other and to connect just the first module of this chain with the laptop in the vehicle.

## 3.2 Features of the ES400 Line

---

### 3.2.1 Advantages of the Decentral Wiring Concept

- The compact ES400 modules can be mounted close to the sensors with short connection cables.
- The simple assembly and wiring principle (daisy chain topology) of the modules
  - requires only one common cable between the modules for power supply and data transfer
  - considerably reduces the setting-up times for tests
  - simplifies the maintenance and the extension of the test setup
- The only item in the vehicle is the laptop which is connected to the modules with just one cable.
- Test vehicles equipped with an ES400 measurement system can be used flexibly because the vehicles do not have to be modified for changed or new test tasks.

### 3.2.2 Further Features

This list provides an overview of the other features of the ES400 line in addition to decentral cabling:

- The ES400 modules have a very compact design.
- Each module has an LED for localizing the module.
- The A/D Modules of the ES400 family use a XCP-based protocol which is compatible to the existing ETAS Ethernet topology.

The concept fulfills the following requirements:

- high bandwidth to be able to realize lots of channels with high resolutions (typical in measuring and calibration applications) with fast sampling rates
- simple application based on the Ethernet integration in INCA, no complicated setting of bus parameters,
- simple to integrate in measurement and calibration tools manufactured by third-party suppliers due to the use of XCP as application protocol
- support of all probes and pressure sensors used in the automotive industry
- Innovative, battery-saving power supply management
  - automatic power-saving feature (“Standby”)
  - “Wake Up” via the Ethernet interface
- Part of the ETAS Tool Suite
- Daisy Chain Configuration Tool (stand-alone operation)
- Modules suitable for use in automotive applications; suitable for use in the development environment and in the vehicle on test drives:
  - Housing, connectors and cables waterproof and dustproof in acc. with IP65 or IP67; designed for use in the engine compartment or the outside area of the vehicle

- rugged to acceleration or mechanical damage
- rugged to extreme environmental conditions (temperature, dampness, EMC)
- very low temperature coefficients contribute to the reduction in the number of measurement errors

For the complete technical data of the ES410.1, refer to the chapter “Technical Data” on page 65.

### 3.3 Housing

A sturdy metal housing is used for the ES410.1; it has ports on the front of the device so it can fit into tight spaces. The ES410.1 is specifically designed to be installed in engine compartment, but also in the passenger cell.

The housings of the ES400 family can quickly and easily be connected to one another to create a measurement system (see section 5.2 on page 33). The modules can easily be screwed directly to a carrier system or attached to it using cable fasteners both in the vehicle and in the lab.

These simple and uncomplicated ways of attaching the modules make them flexible in terms of assembly. These methods of attachment can also be used in harsh environmental conditions (salt fog, dirt).



#### CAUTION

##### Loss of Features as defined by IP67!

Do not open or change the module housing!

Works on the module housing may be executed only by qualified technical personnel.

### 3.4 Ports

All ports of the ES400 measuring modules are on the front of the device (see Fig. 3-2 on page 15).

The LEMO and Souriau connectors used adhere to protection class IP67. All ports are reverse-polarity protected due to the exclusive use of coded LEMO or Souriau connectors.

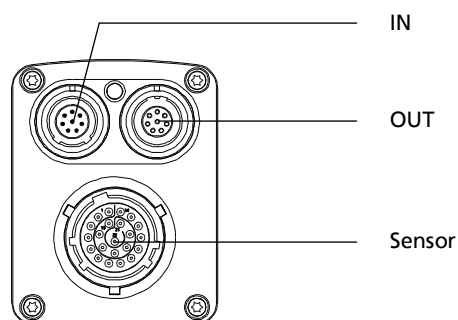

Fig. 3-2 Front

### 3.4.1 “Sensor” Port

The front of the ES410.1 features a 22-pin Souriau port to which four sensors can be connected using an adapter cable. An individual sensor power supply port is available for each sensor.

The use of a “cable tail” or “whip” solution with just one connector makes it possible to change the modules quickly within complex test setups.

### 3.4.2 Daisy Chain Ports (“IN”, “OUT”)

The modules are connected using a daisy chain topology. This means each module has an explicit input socket and an explicit output socket. The Ethernet data line and the supply voltage are routed through the daisy chain ports of the module:





- “IN” (input)
- “OUT” (output)

The PC, the modules ES523, ES59x, ES600.2, ES891, ES910.3 or the Drive Recorder ES720 are connected at the “IN” port (input). The “OUT” port (output) is connected to the following module of the ES400 line or remains free on the last module of the chain.

## 3.5 LED

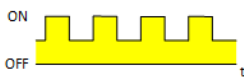

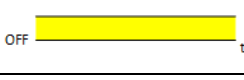
Every module has an LED. It indicates the following states of the module:

### 3.5.1 Operational State



Display		State
	off	No power supply to the module
	yellow flashing 0,25 s on / 0,25 s reduced	Initialization of the module not yet complete - Further modules in a chain not initialized yet
	green illuminated semi bright	Normal
	yellow illuminated semi bright	At least one sensor supply voltage is activated.
	green flashing 0,1 s on / 1,9 s off	Standby No Ethernet connection established



### 3.5.2 Service State

Display		State
	red flashing 0,25 s on / 0,25 s reduced	Module identification
	red flashing 0,1 s on / 0,6 s off	Update of the firmware / HDC

### 3.5.3 Functional State

Display		State
	yellow-red flashing 0,5 s yellow reduced / 0,5 s red reduced	Warning Overload on a sensor supply voltage channel
	red illuminated fully bright	Error during self-test
	red illuminated semi bright	Internal error

## 4 Hardware Description

---

This chapter contains information on the following topics:

- "Features of the ES410.1" on page 18
- "Block Diagram" on page 19
- "Measurement Channels" on page 19
- "Data Transfer" on page 23
- "Power Supply" on page 28
- "Configuration" on page 31
- "Tool Integration" on page 31
- "Firmware Update" on page 31
- "Calibration" on page 31

### 4.1 Features of the ES410.1

---



**Fig. 4-1** ES410.1 Housing

The ES410.1 A/D Module is a member of the family of ES400-Modules. The ES410.1 can acquire analog voltages at eight input channels.

For the complete technical data of the ES410.1, refer to the chapter "Technical Data" on page 65.

## 4.2 Block Diagram

The ES410.1 is a module with eight identical measurement channels, two shared Ethernet interfaces and a power supply.

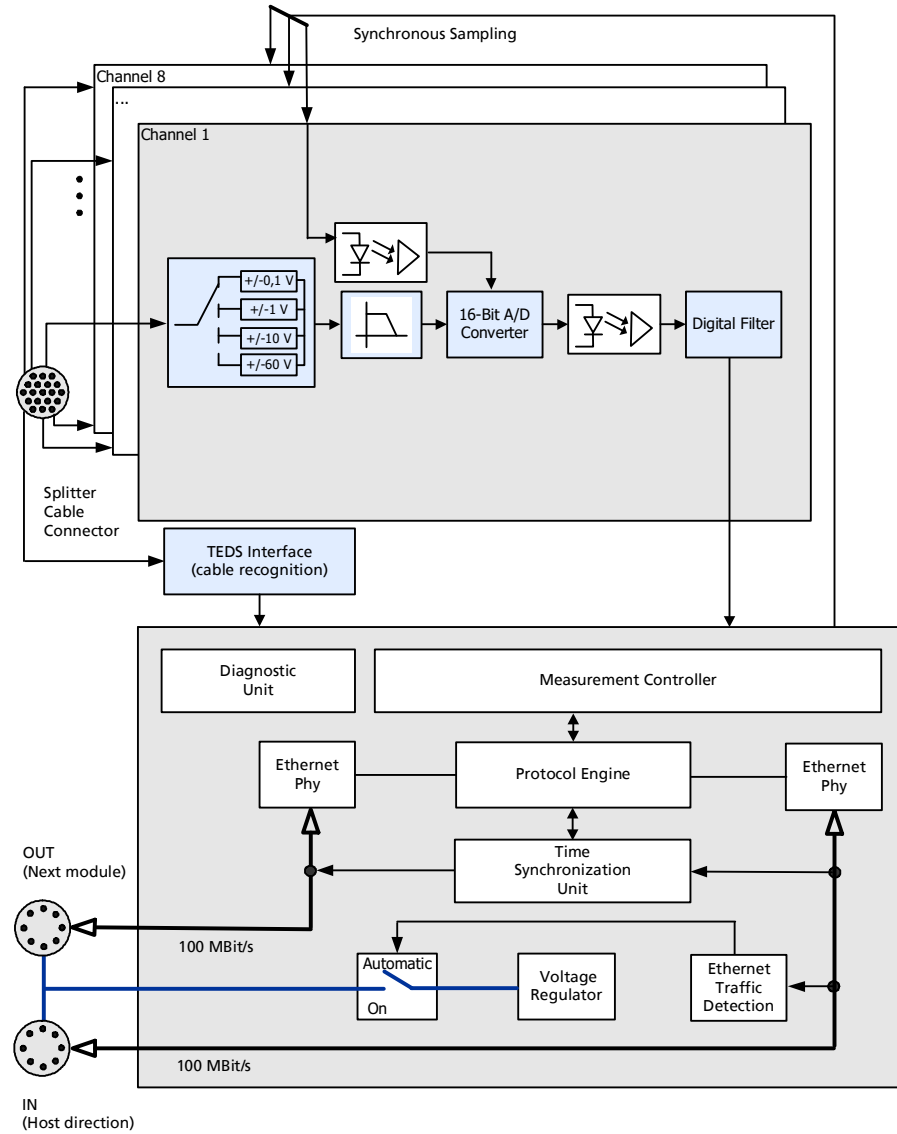
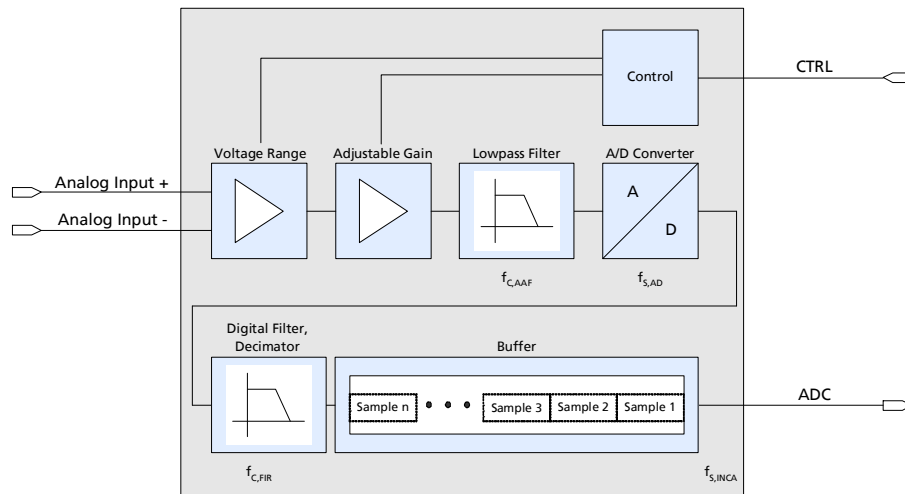

Fig. 4-2 Block Diagram

## 4.3 Measurement Channels

All measurement channels of the ES410.1 are identical. Every measurement channel consists of the function groups Signal Processing and Filter.

### 4.3.1 Signal Processing and Filters



**Fig. 4-3** Signal Processing and Filters of a Measurement Channel

The level of the input signal is limited in every measurement channel after the overvoltage protection by a capacitively compensated voltage divider. An amplifier adjusts the input signal to the following analog anti-aliasing filter according to the selection of the input voltage range. This 4th order analog filter with Butterworth characteristics has a cutoff frequency of 10 kHz.

An A/D converter digitizes the output signal of the analog filter. The individual A/D converter available in every measurement channel guarantees synchronous sampling of the measure signals.

A digital filter then processes the digital signal. The digital filter can be configured in the application program. The data is written to a data buffer at the output of the digital filter. It can be queried there by the application program.

#### Compensating Group Delay

The group delay is the time it takes the input signal of an analog or digital filter to pass the filter. In the application program (e.g. INCA MDA), the signal must be delayed to compensate for the group delay.

A special feature of the ES410.1 is the compensation of the group delay within the module. The group delays of the analog anti-aliasing filter and the configurable digital filter are taken into consideration in this process. The signal in the application program (e.g. in MDA) no longer has to be delayed to compensate for the group delay.

#### Setting the Filter

For an overview of the possible settings and details of the technical data of the digital filter, please refer to section 7.10.4 on page 74.

#### Digital Filter Configuration Recommendations

The -3 dB cutoff frequency of the digital filter system of the ES410.1 can be configured in the application program.

To avoid aliasing effects, be sure to observe recommendations for the configuration of the filter depending on the selected INCA sampling rate. The following table contains the relevant notes.

Symbol	Meaning	Setting
$f_{C,AAF}$	-3 dB cutoff frequency HW anti-aliasing filter	10 kHz (fixed)
$f_{S,AD}$	Sampling rate of the A/D converter	40 kHz
$f_{C,FIR}$	-3 dB cutoff frequency FIR filter (settable)	Recommendation: $f_{C,FIR} \leq 0.4 * f_{S,INCA}$
$f_{S,INCA}$	INCA sampling rate	Configuration in the application program

### Examples

To represent the group delay with digital filters, a test signal was sent to two filters of the same type:

- Filter A without compensation of the group delay
- Filter B with compensation of the group delay

The configuration of both filters is identical. The test signal is sampled with the sampling rate  $f_{S,INCA} = 2 \text{ kHz}$  (0.5 ms). The filter channel was set to a cutoff frequency  $f_{C,FIR} = 200 \text{ Hz}$ .

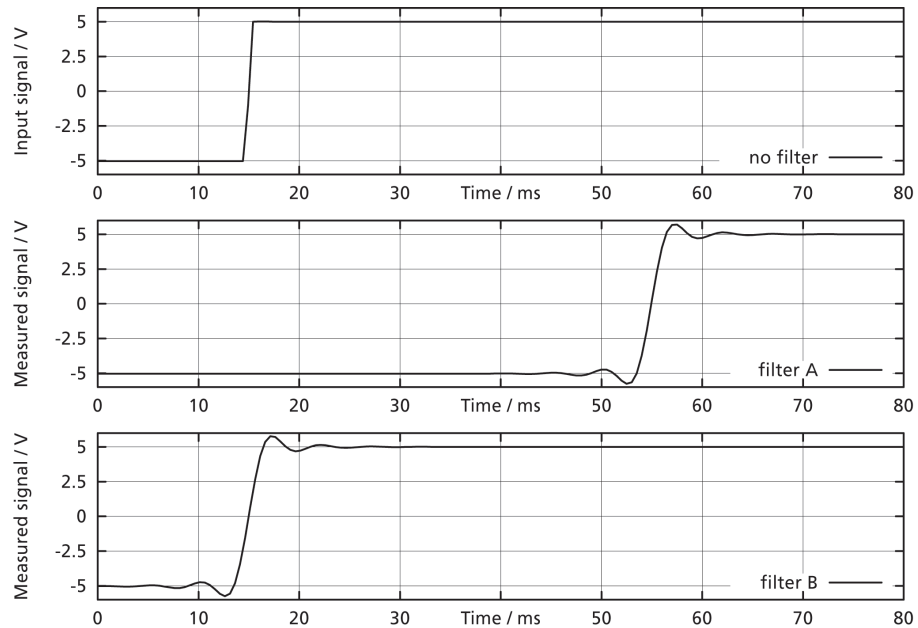

**Fig. 4-4** Filter with and without Compensation of the Group Delay

Fig. 4-4 on page 21 shows the relevant signal trace:

- in the upper part of the figure without a filter,
- in the middle part of the figure with filter A (without group delay compensation) and
- in the lower part of the figure with filter B (with group delay compensation).

### 4.3.2 Galvanically Isolation

The measurement channels are galvanically isolated from each other and from the power supply. The digitized transfer of the measurements on an Ethernet connection implicitly results in a separation of the measurement channels from the supply voltage.

### 4.3.3 Maximum Input and Common-Mode Voltages

The maximum input voltage between two inputs and the maximum voltage between an input and the case ground is 60 V DC/ 30 V AC. For an explanation of the maximum input and common-mode voltages, see Fig. 4-5 on page 22 and the example.

All capacitors between the inputs ( $U_{in+}$  and  $U_{in-}$ ) and case ground have the same capacity. The maximum voltage between any input and case ground is also 60 V DC/ 30 V AC.

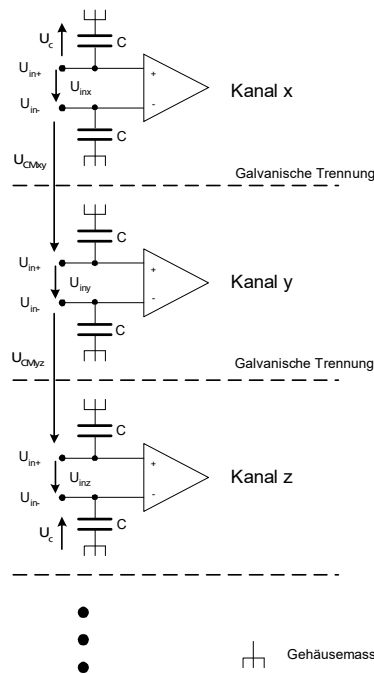

**Fig. 4-5** Maximum Input and Common-Mode Voltages

#### Example

For the given input voltages  $U_{inx}$ ,  $U_{iny}$ ,  $U_{inz}$  and the common-mode voltage  $U_{CMxy}$ , the maximum allowed common-mode voltage  $U_{CMyz}$  is to be calculated.

$$U_{inx} = 10 \text{ V}$$

$$U_{iny} = 5 \text{ V}$$

$$U_{inz} = 10 \text{ V}$$

$$U_{CMxy} = 15 \text{ V}$$

$$\max (U_{inx} + U_{iny} + U_{inz} + U_{CMxy} + U_{CMyz}) = 60 \text{ V}$$

$$10 \text{ V} + 5 \text{ V} + 10 \text{ V} + 15 \text{ V} + \max (U_{CMyz}) = 60 \text{ V}$$

$$\max (U_{CMyz}) = 60 \text{ V} - 40 \text{ V} = 20 \text{ V}$$

## 4.4 Data Transfer

For data transfer, the ES930.1 as well as the ES4xx and ES63x modules use a 100 Mbit/s Ethernet network connection in duplex operation. The data transfer can be adapted flexibly to suit the test setup and the measurement task.



### NOTE

The complete Ethernet bandwidth is available for both measure data and control variables.  
Calibration procedures can take place in a Rapid Prototyping application without delay with measure data being acquired at the same time.

### 4.4.1 Communication Protocols

The universal ASAM measure and calibration protocol XCP is used for serial communication. On the Ethernet transport and network layer, the UDP/IP protocol is used (see Fig. 4-6 on page 23).

Within the XCP protocol, the modules transfer, among other things, module ID, time stamp and measure and/or stimulation data in an extremely precise and predictable time pattern. The communication protocol used for the modules avoids repeated transfer of protocol data, which takes place, for example, in handshake-based systems. This makes a high bandwidth available for reference data.

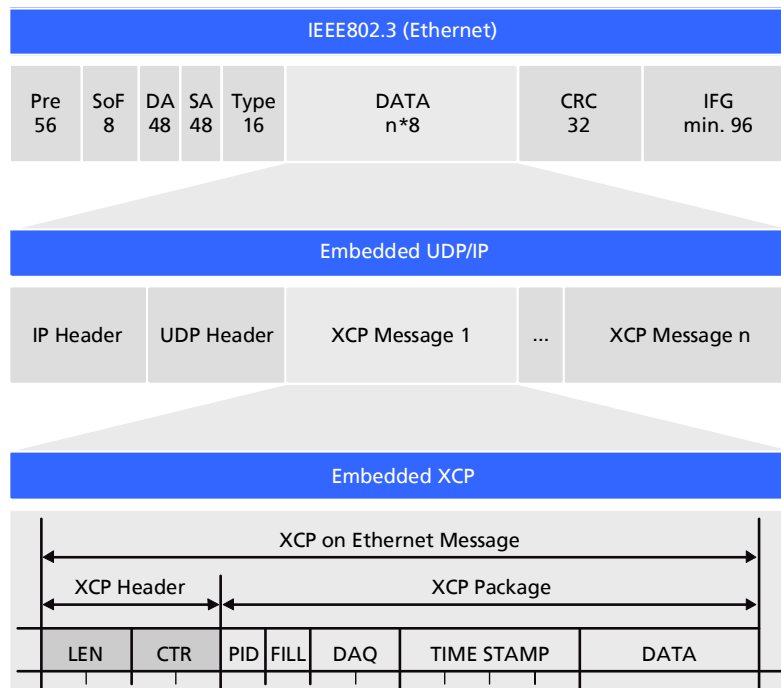

**Fig. 4-6** Message Format "XCP on UDP" (Schematic)

Using the UDP/IP standard for data transfer makes it possible to connect the modules directly to a PC, a router or a switch. In XCP communication, the PC has the master function.

No real-time requirements are made. Data acquisition on a PC, which generally does not have to fulfil high real-time requirements, can thus be connected directly to an ES400 chain. With a real-time-capable master, such as, for example, a Rapid Prototyping system, lots of different kinds of I/O signal can be accessed with extremely short cycle times.

**NOTE**

The communication protocol used by the ES400 family makes it possible for third-party suppliers to use the communication protocol for their own, non-ETAS applications once the modules have been configured with the „ES4xx Configuration Tool from ES4xx\_DRV\_SW“ .

## 4.4.2 Realization

### Time Slice Procedure

The modules in the daisy chain transfer the data to the master using a 100 MBit/s Ethernet connection time-controlled, i.e. without being prompted. The PC assumes the function of the master. In the network, the modules respond like a single Ethernet device with one MAC address.

All daisy chained modules have a generator which is only activated in the last module of each chain after the test setup has been connected to the PC. The frequency of the generator or the period duration of the time slices generated can be set in the application program. It corresponds to the measuring frequency of the measurement channel with the highest acquisition rate in the chain.

A binary counter linked to the generator periodically counts the time slices generated (value range:  $2^{16} = 65536$ ). The last module in the chain sends the relevant number of time slices in the IP header. The Ethernet frames are transferred from module to module within the chain.

Each module in the chain receives bandwidth to transfer its measure data in freely selectable time slices assigned within the period of the binary counter. The module uses the number of the time slice to determine whether it can insert an XCP message with its measure data into the current time slice.

The fastest module, which determines the period duration of the time slices generated, transfers data in every time slice. An Ethernet frame then contains at least one XCP-on-Ethernet data package. The length of the Ethernet frame transferred inside a time slice increases with the number of modules which can insert their data into this time slice.

The numbering of the time slices ensures, for example, that two modules which work with half the sampling rate of the generator never attach their data to the same Ethernet frame. One module uses only the odd frame numbers and the other only the even ones. This mechanism also ensures for certain that the assigned frames do not exceed the length of a time slice.

The measure data is automatically distributed to the frames so that the available bandwidth is used perfectly.



The time slice procedure makes both measurements of fast signals and the acquisition of a large number of channels with a low sampling rate possible.

If a few fast signals and lots of slow ones are acquired in a chain, the slow signals can be transferred in time multiplex procedure.

**NOTE**

Due to data transfer by Ethernet, there are virtually no limitations in terms of the number of modules in a module chain even with fast sampling rates.

### Clock Generator for Synchronizing Modules

The clock generator for the synchronization of the modules is either the first module in an module chain or the network module ES600. In both cases, the measure data is synchronized with a tolerance of one microsecond. Using an ES600 network module, several ES4xx/ES63x/ES93x chains can be synchronized with each other or with the modules of the ES600 series. The ES4xx/ES63x/ES93x and ES600 modules add the relevant time stamp to the Ethernet data package for every measure value. The exact assignment in terms of time of the measure data of the ES4xx/ES63x/ES93x and ES600 modules used resulting from this makes precise analysis of the correlations of measure signals possible.

### Synchronizing the Modules and INCA Signal Processing

Data transfer does not require synchronization of the local timebases of the ES4xx/ES63x/ES93x modules. The time stamps are still synchronized by the system to be able to correlate measure data and sampling times of different modules in terms of time after data transfer. A precise time and drift synchronization takes place in the modules via a hardware connection.

No bandwidth is required for this, unlike time synchronization in acc. with IEEE1588 (Precision Time Protocol). The modules add the time stamp to the Ethernet data package for every measure date.

The combination of time stamp synchronization, full duplex and time slice procedure results in a very high reference data rate of the modules.

### 4.4.3 Examples

#### Example 1

Fig. 4-7 on page 26 shows an example of an application with three concatenated ES400 modules with the same acquisition rates. The transfer scheme for this configuration is shown in Fig. 4-8 on page 26.

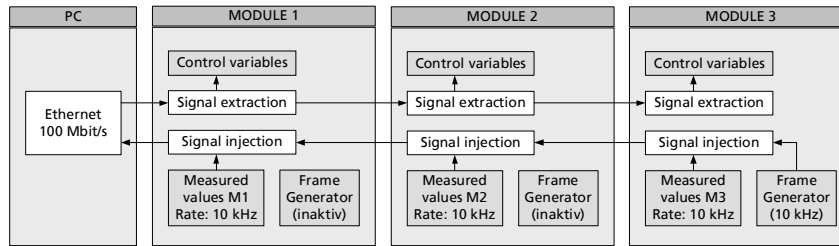

Fig. 4-7 Time-Multiplex Data Transfer Between an ES400 Module Chain and a PC

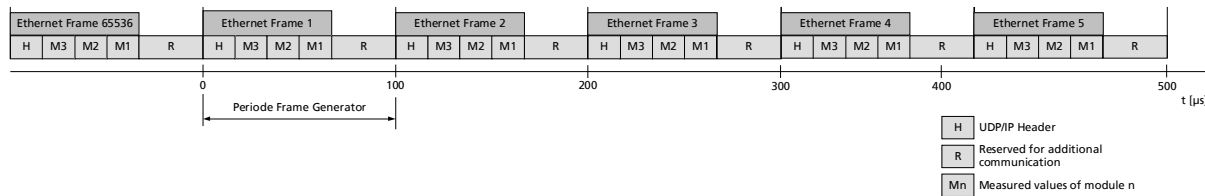
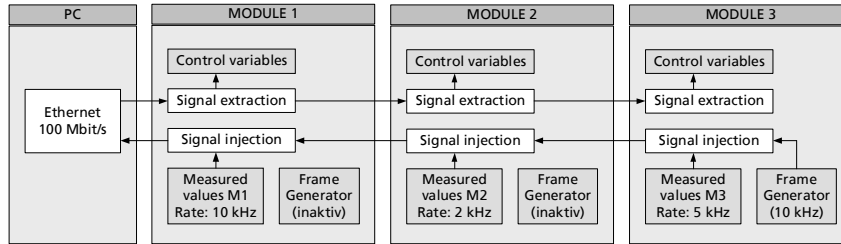

Fig. 4-8 Transfer Scheme for Example 1 (Simplified, Not True to Scale)

In this example, the third module periodically generates  $2^{16}$  (65536) time slices each 100 microseconds long. Modules 1, 2 and 3 acquire measurements with the same rate of 10 kHz each. Module 1, Module 2 and Module 3 link their measurements to each time slice (see Fig. 4-8 on page 26). Independently of this, control variables can be transferred at the same time from the PC to the modules.

### Example 2

Fig. 4-9 on page 27 shows an example in which three modules with different acquisition rates are linked to each other. The transfer scheme for this configuration is shown in Fig. 4-10 on page 27.



**Fig. 4-9** Time-Multiplex Data Transfer Between an ES400 Module Chain and a PC

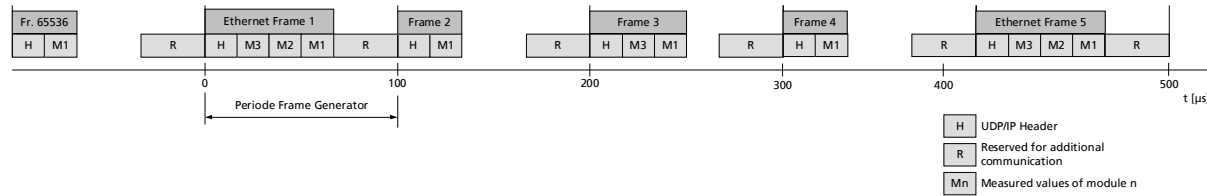

**Fig. 4-10** Transfer Scheme for Example 2 (Simplified, Not True to Scale)

In this example, the third module periodically generates  $2^{16}$  (65536) time slices (Ethernet frames) each 100 microseconds long. The ES400 modules 1, 2 and 3 acquire measurements at a rate of 10 kHz, 2 kHz and 5 kHz. Module 1 links its measurements to each Ethernet frame, module 2 to every fifth Ethernet frame and module 3 to every second Ethernet frame (bottom figure).

Independently of this, control variables can be transferred at the same time from the PC to the modules.

## 4.5 Power Supply

---

### 4.5.1 Supply Voltage

DC/DC converters in every module guarantee both the operation as well as the launch of the ES400 modules with supply voltages between 5 V and 50 V DC over the entire temperature range.

With the power supply management of the ES410.1, you can use an automatic power-saving feature ("Standby") as well as a "Wake Up" function via the Ethernet interface.

### 4.5.2 Supplying the ES400 Modules via the Connecting Line

In the simplest application case, the modules are directly linked to one another. They are connected to the supply voltage via the previous module all the way.

### 4.5.3 Additional Supply of the ES400 Modules via a Y-Boost Cable

If the supply voltage at the input of a module is too low because of the current consumption of the previous modules, multiple feeding of the supply voltage can guarantee this and the following modules sufficient supply voltage in longer module chains.

In this application case, you have to split the module chain. Swap the existing connection cable between the two modules for a Y boost cable for additional, direct feeding of the supply voltage. The module chain is now closed again and the power supply of the following modules guaranteed.

The special design of the Y boost cable avoids reverse feeding into the front parts of the module chain and thus arising potential differences.

#### When is it necessary to use a Y boost cable?

An exact calculation of the current consumption of a module chain is only possible if numerous variables are known:

- supply voltage of the first module at the input
- minimum supply voltage at the last module of the chain
- number and type of the modules
- consumption of sensor power supply of the connected sensors
- cable length
- cable type
- ambient temperature

The necessary minimum voltage for supplying power to the system must be determined individually for each test set-up.



#### NOTE

---

Please contact our local experts to discuss your particular ES410.1 configurations.

**Example 1:**

For module chains which are equipped exclusively with ES410.1 or ES441.1, ETAS recommends the use of Y boost cables if the length of the module chain is longer than 10 modules.

**Example 2:**

For module chains which are equipped exclusively with ES411.1 or ES413.1 or ES421.1, ETAS recommends the use of Y boost cables if the length of the module chain

- is longer than 16 modules (without sensor feeding) or
- is longer than 10 modules (with sensor feeding).

**Example 3:**

For module chains which are equipped exclusively with ES415.1 or ES420.1, ETAS recommends the use of Y boost cables if the length of the module chain

- is longer than 8 modules (without sensor feeding) or
- is longer than 5 modules (with sensor feeding).

**Example 4:**

With a minimum voltage of 7.7 V, no additional feeding is necessary with a Y cable if the module chain consists of the following modules:

- nine ES420.1 or ES421.1 and
- four ES410.1 or ES411.1 or ES413.1 (without sensor feeding) and
- one ES441.1

**Example 5:**

With a minimum voltage of 7.7 V, no additional feeding is necessary with a Y cable if the module chain consists of the following modules:

- five ES420.1 or ES421.1 and
- two ES415.1 (without sensor feeding) and
- one ES441.1

**Example 6:**

With a minimum voltage of 9 V, no additional feeding is necessary with a Y cable if the module chain consists of the following modules:

- nine ES420.1 or ES421.1 and
- four ES410.1 or ES411.1 or ES413.1 (with sensor feeding) and
- one ES441.1

**Example 7:**

With a minimum voltage of 9 V, no additional feeding is necessary with a Y cable if the module chain consists of the following modules:

- five ES420.1 or ES421.1 and
- two ES415.1 (with sensor feeding) and
- one ES441.1



**NOTE**

All examples apply at 85 °C ambient temperature.

## 4.6 Configuration

---

The configuration of the ES410.1 is performed entirely via the GUI within INCA.

The configuration of the individual channels is saved either in INCA or in the individual ES400 modules. In the first case, you can prepare settings for specific measure tasks, e.g. in the lab. The second case is of interest to users who share a test carrier with a corresponding ES400 test setup. In this way, several users can call up the saved configuration directly from the modules.

## 4.7 Tool Integration

---

The ES400 modules can be selected and configured in INCA and support the open protocol XCP-on-Ethernet. This enables easy integration of the modules into other measure software.

The measure system can be connected directly to the PC's Ethernet port. No additional devices or interface converters are necessary.

## 4.8 Firmware Update

---

The firmware of the module can be updated by the user so that future versions of the module can also be used. The firmware update is done with the help of the service software "Hardware Service Pack" (HSP) from the connected PC.

 **NOTE**

During a firmware update, neither the voltage supply nor the Ethernet connection may be interrupted!

## 4.9 Calibration

---

A calibration service for this product is available. Calibrate this product on a regular basis to ensure reliable accuracy of the measured values.

 **NOTE**

ETAS recommends a calibration interval of 12 months.

The seal of approval on the product shows the date of the last calibration. In the calibration certificate you will find information on the measurement accuracy.

Please contact your local ETAS representative for information on obtaining the calibration service (see chapter "Contact Information" on page 97). For information on ordering the calibration service, refer to chapter "Calibration" on page 95.

## 5 Getting Started

---

This chapter contains information on the following topics:

- "General Installation Recommendations" on page 32
- "Assembly" on page 33
- "Drilling Template" on page 47
- "Applications" on page 48
- "Wiring Examples" on page 50
- "Wiring" on page 55

### 5.1 General Installation Recommendations

---

#### 5.1.1 Assembly Environment and Components for Attaching the Module



#### CAUTION

---

**The module can be damaged or destroyed.**

The modules of the ES400 line are only admissible for assembly and operation on components or in locations which guarantee adherence to the technical data of the modules during operation (see chapter 7 on page 65).

Adhere to the technical data of the modules for operation, such as

- the vibration resistance of the modules (only assemble modules on sprung masses, for example, and not on wheel suspensions or directly on the engine) and
- the temperature resistance of the modules (for example do not assemble modules on the engine, turbocharger, exhaust manifold or within their vicinity).

#### 5.1.2 Potential Equalization in the Vehicle and Mounting the Modules



#### CAUTION

---

**Potential equalization in the vehicle over the shield of the Ethernet connecting cables of modules may occur!**

Mount the modules only to components with the same electrical potential or insulate the modules from the components.



### 5.1.3 Guarantee of Features as defined by IP67



#### CAUTION

##### Loss of Features as defined by IP67!

Water standing at the pressure balance element damages the membrane!  
Please observe which way the module is pointing when installing vertically!

If installing the ES400 modules where water or other liquids could collect, install the modules so that the (black) pressure balance element on the back of the modules is not pointing upwards or that liquids can drain away.

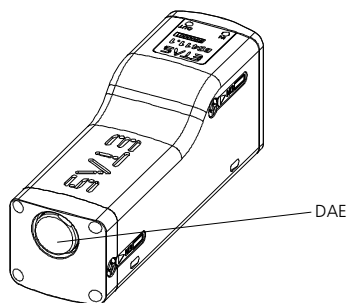
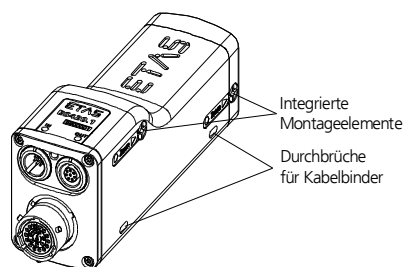

**Fig. 5-1** Position of the Pressure Balance Element

Standing liquids or liquids which do not flow away from the pressure balance element can permanently damage the membrane. The module then loses the features defined by IP67.

## 5.2 Assembly

### 5.2.1 How to Connect and Attach ES400 Modules



**Fig. 5-2** How to Attach ES400 Modules

#### Integrated Assembly Elements

Every ES400 module has two integrated assembly elements to enable different assembly possibilities. If several modules are required in one location, they can be connected quickly, without any additional parts, using the integrated assembly elements to form a measuring instrument block (cascading). The two integrated assembly elements also make it possible to screw the modules directly onto other components (parts of the vehicle body, units).

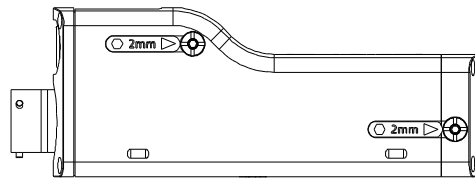

**Fig. 5-3** Accessing the Integrated Assembly Elements

You can access and use the two integrated assembly elements of a module via the holes indicated (see Fig. 5-3 on page 34) on the right-hand side of the module.

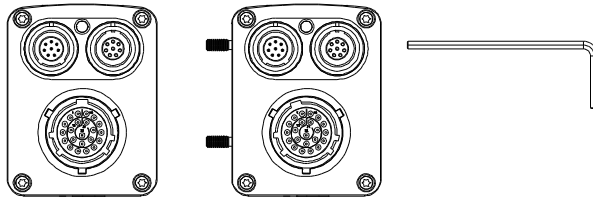

**Fig. 5-4** Unscrewed Integrated Assembly Elements

### Openings for Cable Fasteners

Every module base has two openings each on the right and left-hand side for attaching the modules to other components using cable fasteners.

### Examples for mounting

Examples for mounting using the different possibilities to connect and attach ES400 modules are:

- Connect ES400 modules with the integrated assembly elements (cascading)
- Attaching ES400 modules with the integrated assembly elements:
  - on DIN rails with ES4xx angle brackets (left)
  - on other components
- Attaching ES400 modules with screws:
  - on DIN rails with ES4xx angle brackets (right)
  - on other components
- Attaching ES400 modules with cable fasteners:
  - on DIN rails with ES4xx angle brackets (left)
  - on DIN rails with ES4xx angle brackets (right)
  - on other components

## 5.2.2 Connecting Several ES400 Modules Mechanically

You can combine any ES400 modules with each other using the integrated assembly elements of the ES400 modules.

Here, you connect the ES400 modules using the integrated assembly elements.

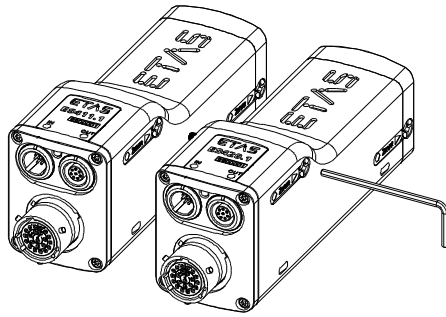

**Fig. 5-5** Connecting Several ES400 Modules Using the Integrated Assembly Elements

### Rules on Connecting the Modules

Observe the following rules when connecting the modules as required:

#### NOTE

The two integrated assembly elements can only be accessed from the right-hand side of the module and can only be turned using an Allen key. When connecting the modules, you must therefore always screw the module on the right to the module on its left. You can only successively screw additional modules, but not module blocks, onto the right-hand side of this module block. When creating module blocks, observe the defined order.

### Preparing the Modules

To position the modules:

1. Position the modules to be connected in the required order.

#### NOTE

Both modules' ports must point left.

2. Position the modules so that their fronts are in a line.
3. Hold the two modules together firmly on their outer sides.

### Connecting the Modules

To connect several ES400 modules, you require a 2 mm Allen key (minimum length 20 mm).

**To connect the modules:**

1. Insert the Allen key into a hexagon socket on the right-hand side of the right-hand module.

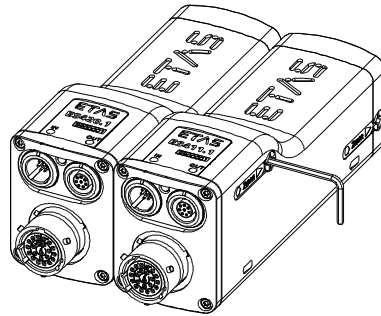

**Fig. 5-6** Connected ES400 Modules

2. Screw the two modules by turning the Allen key clockwise as far as it will go within the module.

**i NOTE**

Screw the two modules together without getting them off-thread!

Both modules are now connected mechanically on one side.

3. Insert the Allen key into the other hexagon socket of the right-hand module.
4. Screw the two modules by turning the Allen key clockwise as far as it will go within the module.

**i NOTE**

Screw the two modules together without getting them off-thread!

Both modules are now completely connected mechanically.

## Connecting to Other Modules

**i NOTE**

You can only successively screw additional modules, but not module blocks, onto the right-hand side of this module.

To connect the ES400 module to other modules, you require a 2 mm Allen key (minimum length 20 mm).

**To connect to other modules:**

1. Assemble other modules in accordance with the procedure described in the section 5.2.2 on page 34.

### 5.2.3 Attaching ES400 Modules to Other Components Using the Integrated Assembly Elements

The integrated assembly elements of the ES400 modules can not only be used to connect modules to each other but also to connect them to other components.

Here, you connect the ES400 module to the component using the integrated assembly elements. Screwing the two together works in the same way as connecting several modules.

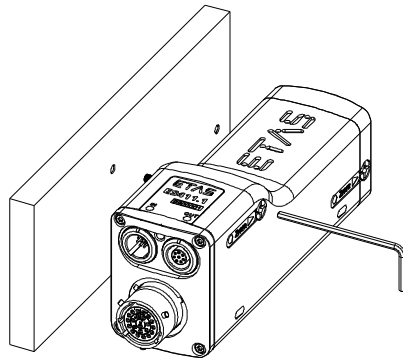

**Fig. 5-7** Attaching a Module to Other Components with the Integrated Assembly Elements

#### Rules on Attaching the Modules to Other Components

Observe the following rules when connecting the modules as required to other components:

##### **NOTE**

The two integrated assembly elements can only be accessed from the right-hand side of the module and can only be turned using an Allen key. You therefore have to screw the module to the other component from the right. You can only successively screw additional modules, but not module blocks, onto the right-hand side of this module.

#### Preparing the Component

##### To cut the thread in the component:

1. Cut two M3 threads into the selected component.  
The threads should be cut 8 mm deep.

##### **NOTE**

Use the drilling template (see Fig. 5-13 on page 47).

#### Connecting the Module to the Component

To connect the ES400 module to the component, you require a 2 mm Allen key (minimum length 20 mm).

**To connect the module and the component:**

1. Position the module to the right of the other component.
2. Align the integrated assembly elements of the module with the drill holes.
3. Insert the Allen key into a hexagon socket on the right-hand side of the module.
4. Screw the two parts together by turning the Allen key clockwise as far as it will go within the module.

**NOTE**

Screw the two parts together without getting them off-thread!

Both parts are now connected mechanically on one side.

5. Insert the Allen key into the other hexagon socket of the module.
6. Screw the two parts together by turning the Allen key clockwise as far as it will go within the module.

**NOTE**

Screw the two parts together without getting them off-thread!

Both parts are now completely connected mechanically.

**Connecting to Other Modules****NOTE**

You can only successively screw additional modules, but not module blocks, onto the right-hand side of this module.

To connect the ES400 module to other modules, you require a 2 mm Allen key (minimum length 20 mm).

**To connect to other modules:**

1. Assemble other modules in accordance with the procedure described in the section 5.2.2 on page 34.

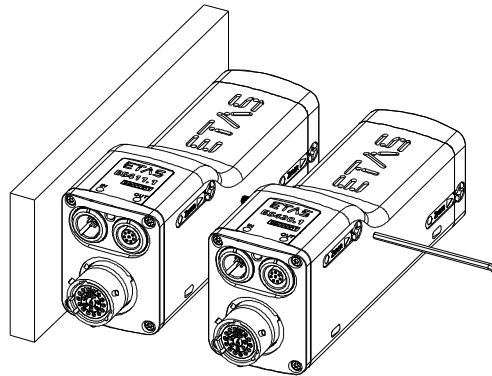

**Fig. 5-8** Connecting to Other Modules

## 5.2.4 Attaching ES400 Modules on DIN Rails with the Integrated Assembly Elements

With the integrated assembly elements of the ES400 modules, you can not only connect the modules with each other, but also with DIN rails.

For this fastening variant, you connect the ES400 module with the DIN rail using an ES4xx angle bracket (left). The screw connection follows the principle of connecting several modules.

Fasten the ES400 modules on DIN rails with the integrated assembly elements using the following steps:

1. Connect the module with the ES4xx angle bracket (left).
2. Connect the module with additional modules (as required).
3. Connect the ES4xx angle bracket with the DIN rail.

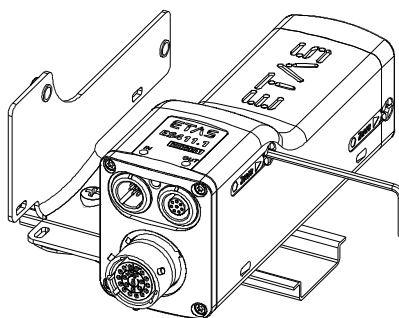

**Fig. 5-9** Fastening to an ES4xx Angle Bracket (left) using the Integrated Assembly Elements

## Rules on Connecting the Modules on the DIN Rails using the ES4xx Angle Bracket (left)

To be able to fasten the modules in the desired arrangement with the ES4xx angle bracket (left) on DIN rails, observe the following rules:



### NOTE

The two integrated assembly elements are accessible only from the right side of the module and can be rotated with a hex key.

For this reason, the module must always be screwed onto the ES4xx angle bracket (left) from the right side.

Additional modules can only be screwed onto the right side of this module, but not any module blocks.

## Connect the Module with the ES4xx Angle Bracket (left)

Connecting the ES400 module with the ES4xx angle bracket (left) requires a 2 mm hex key (minimum length 20 mm).

### Connecting the module and the ES4xx Angle Bracket (left):

1. Position the module to the right of the ES4xx angle bracket (left).
2. Align the integrated assembly elements of the module with the bores.
3. Insert the hex key in a hexagon head on the right side of the module.
4. Screw the parts together by turning the hex key clockwise to the stop within the module.



### NOTE

Screw the two parts together without canting the threads!

Both parts are now mechanically connected on one side.

5. Insert the hex key in the other hexagon head of the module.
6. Screw the parts together by turning the hex key clockwise to the stop within the module.



### NOTE

Screw the two parts together without canting the threads!

Both parts are now completely connected mechanically.



## Connecting with Additional Modules



### NOTE

Additional modules can only be screwed onto the right side of this module, but not any module blocks.

Connecting the ES400 module with additional modules requires a 2-mm hex key (minimum length 20 mm).

#### Connecting with additional modules:

1. Connect additional modules according to the procedure described in chapter 5.2.2 on page 34.

## Connecting the ES4xx Angle Bracket with the DIN Rail

### Connecting the ES4xx Angle Bracket (left) with the DIN rail

1. Place the ES4xx angle bracket onto the DIN rail.
2. Insert the hooks of the ES4xx angle bracket into the upper part of the DIN rail.
3. Engage the ES4xx angle bracket in the DIN rail by pressing on the ES4xx angle bracket or the module.

The module connected with the ES4xx angle bracket is fastened to the DIN rail.

## 5.2.5 Attaching ES400 Modules to Other Components with Screws

Here, you connect the ES400 module to the component using two additional M3 screws which are screwed into the drill holes of the component. The integrated assembly elements of the module are not used.

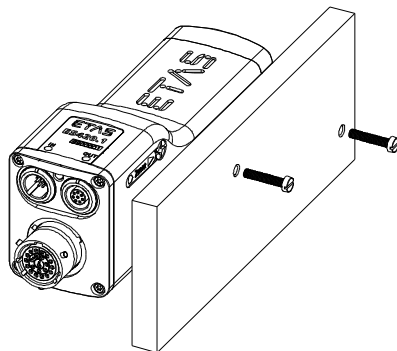

**Fig. 5-10** Attaching to Other Components Using Additional Screws

## Rules on Attaching the Modules to Other Components

Observe the following rules when connecting the modules as required to other components:

### **NOTE**

The two integrated threaded holes in the module are only accessible from the right-hand side of the module.

You therefore have to screw the other component onto the module from the right.

Once the module is screwed to the other component, you cannot screw any further modules to this one.

## Preparing the Component

### **NOTE**

The pivot of the integrated assembly element can be screwed around 6 mm out of the module.

### To drill the openings in the component:

1. Drill two holes in the selected component.

### **NOTE**

Use the drilling template to prepare the component (see Fig. 5-13 on page 47).

## Connecting the Module to the Component

To connect the ES400 module to the component, you need two screws M3 and a screwdriver.

### To connect the module and the component:

1. Position the module to the right of the other component.
2. Align the threaded drill holes of the integrated assembly elements on the right-hand side of the module to the openings in the component.
3. Insert one screw into a hole in the component.
4. Screw the screw from the right-hand side of the component into the module.

### **NOTE**

Screw the two parts together without getting them off-thread!

Both parts are now connected mechanically on one side.

5. Insert the other screw into the other hole in the component.

6. Screw the screw from the right-hand side of the component into the module.

**NOTE**

Screw the two parts together without getting them off-thread!

Both parts are now completely connected mechanically.

## Connecting to Other Modules

**NOTE**

If a module has been screwed to the other component, no other modules can be screwed to this module component connection.

You can attach several ES400 modules to the other component using the method described in this chapter if you first connect all modules to be installed with each other step by step (see section 5.2.2 on page 34). The module on the extreme right of the module block is connected to the other component like an individual module - using screws.

### 5.2.6 Attaching ES400 Modules on DIN Rails using Screws

With the integrated assembly elements of the ES400 modules, you can not only connect the modules with each other, but also with DIN rails.

For this fastening variant, you connect the ES400 module with the DIN rail using an ES4xx angle bracket (right) and two additional M3 screws inserted through their bores. The integrated assembly elements of the module are not used.

Fasten the ES400 modules on DIN rails with the integrated assembly elements using the following steps:

1. Connect the module with additional modules (as required).
2. Connect the module with the ES4xx angle bracket (right).
3. Connect the ES4xx angle bracket with the DIN rail.

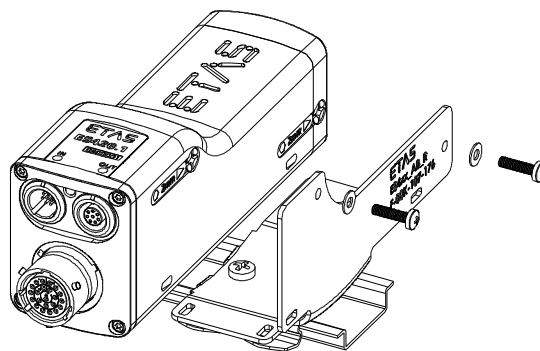

**Fig. 5-11** Fastening on DIN Rails with Additional Screws

## Rules on Connecting the Modules on the DIN Rails using the ES4xx Angle Bracket (right)

To be able to fasten the modules in the desired arrangement with the ES4xx angle bracket (right) on DIN rails, observe the following rules:



### NOTE

The two integrated thread bores in the module for accepting the screws can be accessed only from the right side of the module.  
For this reason, the ES4xx angle bracket (right) must always be screwed onto the module from the right side.  
If the module is screwed onto the ES4xx angle bracket (right), no additional modules can any longer be screwed onto this module.

## Preparing the Component



### NOTE

The pin of the integrated assembly element can be screwed out of the module by approximately 6 mm.

## Connecting the Module with the ES4xx Angle Bracket (right)

To connect the ES400 module with the ES4xx angle bracket (right) requires two M3 screws, two washers and a screwdriver.

### Connecting the module and the ES4xx Angle Bracket (right):

1. Position the module to the left of the ES4xx angle bracket (right).
2. Align the thread bores of the integrated assembly elements on the right side of the module with the through bores of the ES4xx angle bracket (right).
3. Insert one screw through the bore of the ES4xx angle bracket (right).
4. Fasten the screw with the module from the right side of the ES4xx angle bracket.



### NOTE

Screw the two parts together without canting the threads!

Both parts are now mechanically connected on one side.

5. Insert the other screw through the other bore of the ES4xx angle bracket (right).
6. Fasten the screw with the module from the right side of the ES4xx angle bracket.

**NOTE**

Screw the two parts together without canting the threads!

Both parts are now completely connected mechanically.

### Connecting with Additional Modules

**NOTE**

If a module is screwed onto the other component, no additional modules can be screwed onto this module-component connection.

Several ES400 modules can be fastened to the other component with the connection type described in this chapter if you connect all modules to be attached first with each other step by step (see chapter 5.2.2 on page 34). The module which is the furthest to the right of the module block is subsequently connected with the ES4xx angle bracket (right) as a single module and fastened to the DIN rail using screws.

### Connecting the ES4xx Angle Bracket with the DIN Rail

#### Connecting the ES4xx Angle Bracket (right) with the DIN rail

1. Place the ES4xx angle bracket onto the DIN rail.
2. Insert the hooks of the ES4xx angle bracket into the upper part of the DIN rail.
3. Engage the ES4xx angle bracket in the DIN rail by pressing on the ES4xx angle bracket or the module.

The module connected with the ES4xx angle bracket is fastened to the DIN rail.

## 5.2.7 Attaching ES400 Modules to Other Components Using Cable Fasteners

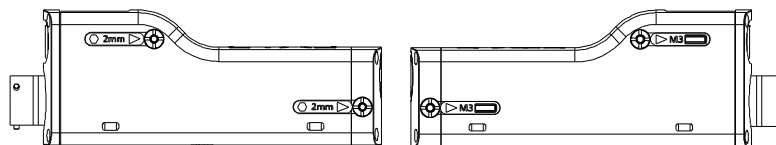

**Fig. 5-12** Openings for Cable Fasteners in ES400 Modules

Every module base has openings for two cable fasteners each on the right- and left-hand side (see Fig. 5-12 on page 45). Just use cable fasteners to quickly attach the modules to other components in the test environment in the immediate proximity of the measuring points.

**CAUTION**

When assembling the modules, observe the admissible temperature range of the cable fasteners used!

### Attaching ES400 Modules to Other Components Using Cable Fasteners

With this method of attachment, you connect the ES400 module or ES400 module blocks to the component using additional cable fasteners inserted through the openings of the modules. The integrated assembly elements of the module are not used.

### Fastening ES400 Modules on DIN Rails using Cable Fasteners

For this fastening variant, the ES400 module or ES400 module blocks are connected with an ES4xx angle bracket (right) or with an ES4xx angle bracket (left) using additional cable fasteners inserted through the breakouts of the module. The integrated assembly elements of the module are not used.

The modules fastened to the ES4xx angle bracket are subsequently attached to the DIN rail.

#### Connecting the ES4xx Angle Bracket with the DIN rail

1. Place the ES4xx angle bracket onto the DIN rail.
2. Insert the hooks of the ES4xx angle bracket into the upper part of the DIN rail.
3. Engage the ES4xx angle bracket in the DIN rail by pressing on the ES4xx angle bracket or the module.

The module connected with the ES4xx angle bracket is fastened to the DIN rail.

### 5.3 Drilling Template

---

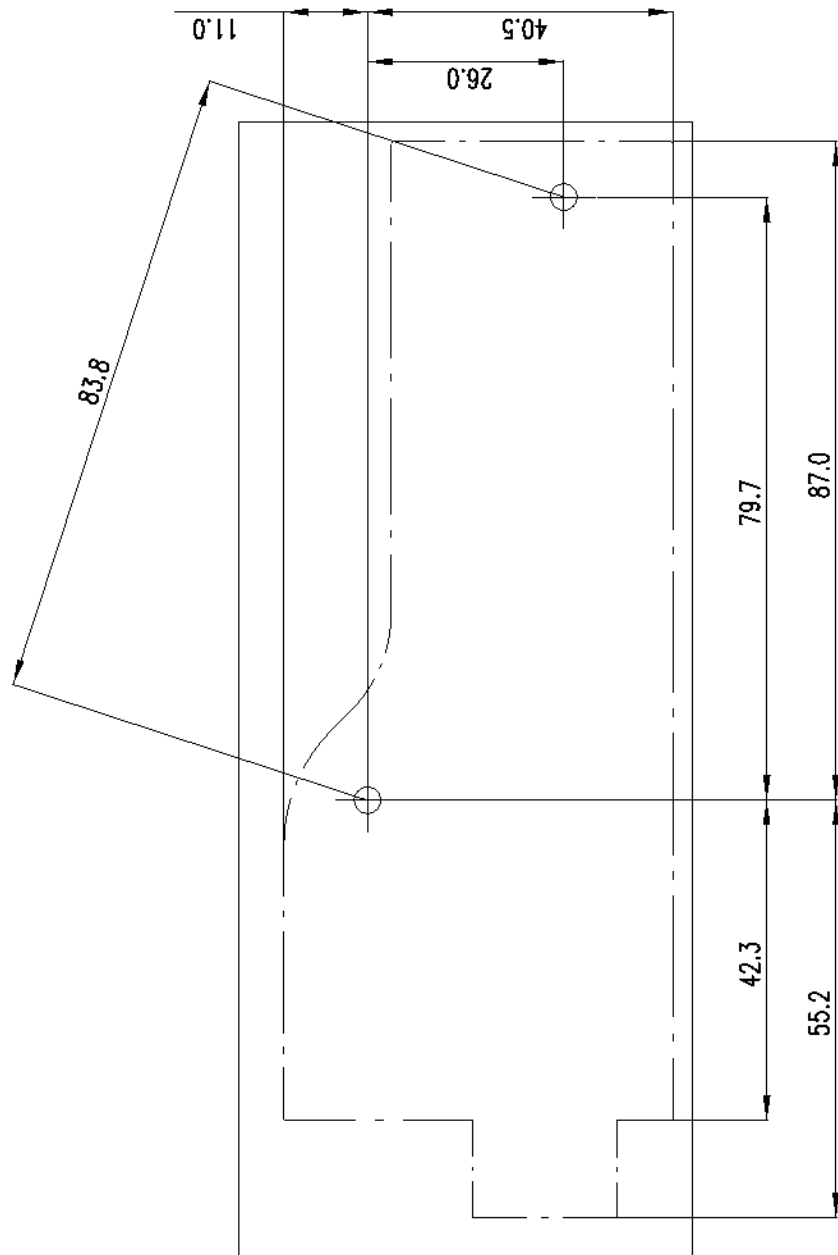

**Fig. 5-13** Drilling Template

## 5.4 Applications

### 5.4.1 General

The modules ES4xx/ES63x/ES93x can be used for the following applications, individually or as part of a daisy chain module chain:

- Measuring and calibrating with INCA
- Rapid Prototyping with INTECRIO (with ES910.3 Prototyping Module or with RTPRO-PC).

Additional ECU and bus interface modules as well as measuring modules are networked with each other via Ethernet and connected with the daisy chain module chain.

The measuring setup can be supplemented with a drive recorder to record all of the data acquired by the connected modules. The drive recorder ES720.1 supports the simultaneous recording of different measurements (multi-recording). The data are stored in the ASAM standard format MDF (Measure Data Format). They can be conveniently evaluated using the Measure Data Analyzer MDA from ETAS and easily be compared with INCA reference measurements. The drive recorder ES720.1 can automatically transfer the recorded measure data encrypted and compressed via LAN, WLAN or wireless radio to customer-specific data servers.

### 5.4.2 ES410.1 with additional ETAS Modules (MC Application)

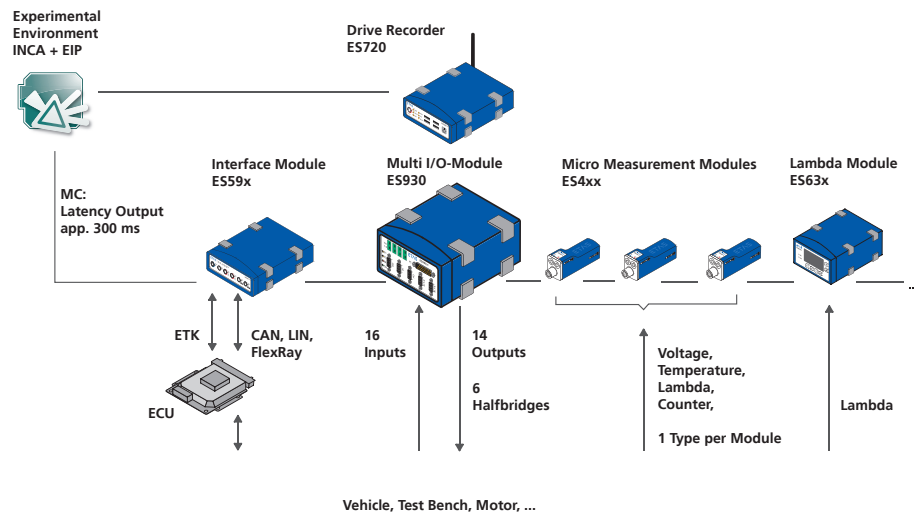

**Fig. 5-14** ES410.1 with additional ETAS Modules for MC Applications

The ETAS Daisy Chain concept enables a simple network architecture since only the ES410.1 or the first module of the module chain is connected with the PC or with the "ETH" port of the ES59x.1.

Additional bus analysis functions on the CAN, LIN and FlexRay buses as well as (X)ETK bypass applications with measuring and calibrating can be made accessible with ES59x modules.



### 5.4.3 ES410.1 with additional ETAS Modules (Rapid Prototyping Application)

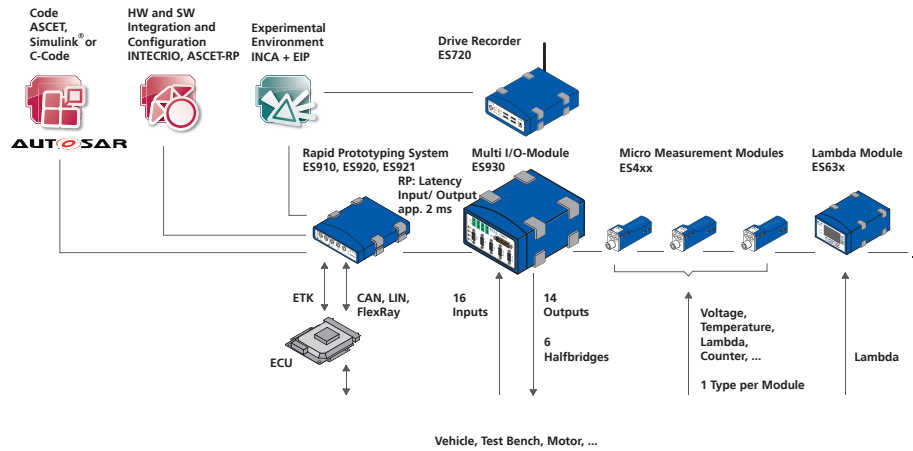

**Fig. 5-15** ES410.1 with ES910.3 and additional ETAS Modules for Rapid Prototyping Applications

The concept of the ES4xx/ES63x/ES93x product family to install the modules as close as possible to the sensors, the chain the modules with each other, and to connect only the first module of this chain with the ES910.3 or the RTPRO-PC, enables a simple network architecture.

The combination of ES910.3 or RTPRO-PC with daisy chain modules can process information from sensors and control actuators in the Rapid Prototyping model.

From the Rapid Prototyping model, it is possible to access the connected modules whose signals are processed directly in the Rapid Prototyping model.

The ES910.3 or RTPRO-PC can access all customary ECU interfaces (ETK, XETK, CAN, LIN, FlexRay) and calculate the new control functions in the bypass.

Parallel to the bypass RP functionality, all control and diagnostics parameters as well as all measure signals of the connected ECU can be accessed with INCA. In addition, INCA/INCA-EIP offers access to all bypass and model sizes created in the ES910.3 Prototyping Module.

## 5.5 Wiring Examples

### 5.5.1 ES400 Modules with additional ETAS Modules (Measurement and Calibration)

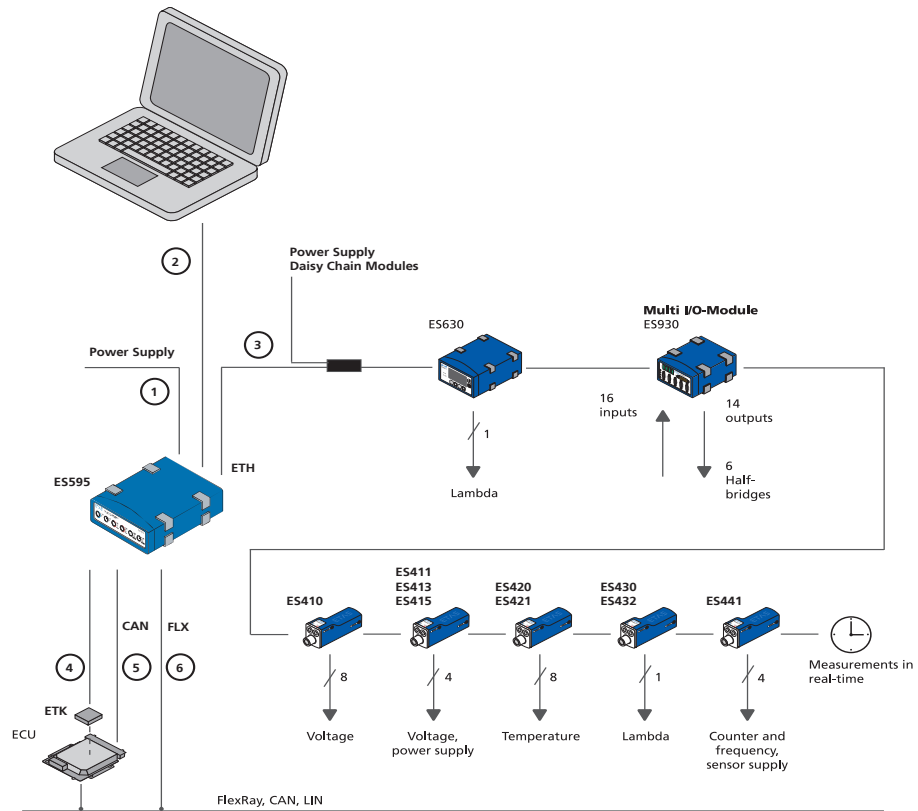

**Fig. 5-16** ES400 Modules with additional ETAS Modules (Measurement and Calibration)

Cable in Fig. 5-16	Function	Order name
1	Power supply cable	CBP120, CBP1205
2	Host connection cable	CBE100
3	Power supply and Ethernet cable Daisy Chain modules	CBEP430, CBEP4305
4	ETK connection cable	CBM150
5, 6	CAN/LIN/FLX connection cable (CAN/LIN/FLX combined)	CBCFI100

### 5.5.2 ES400 Modules with additional ETAS Modules and Drive Recorder (Measurement and Calibration)

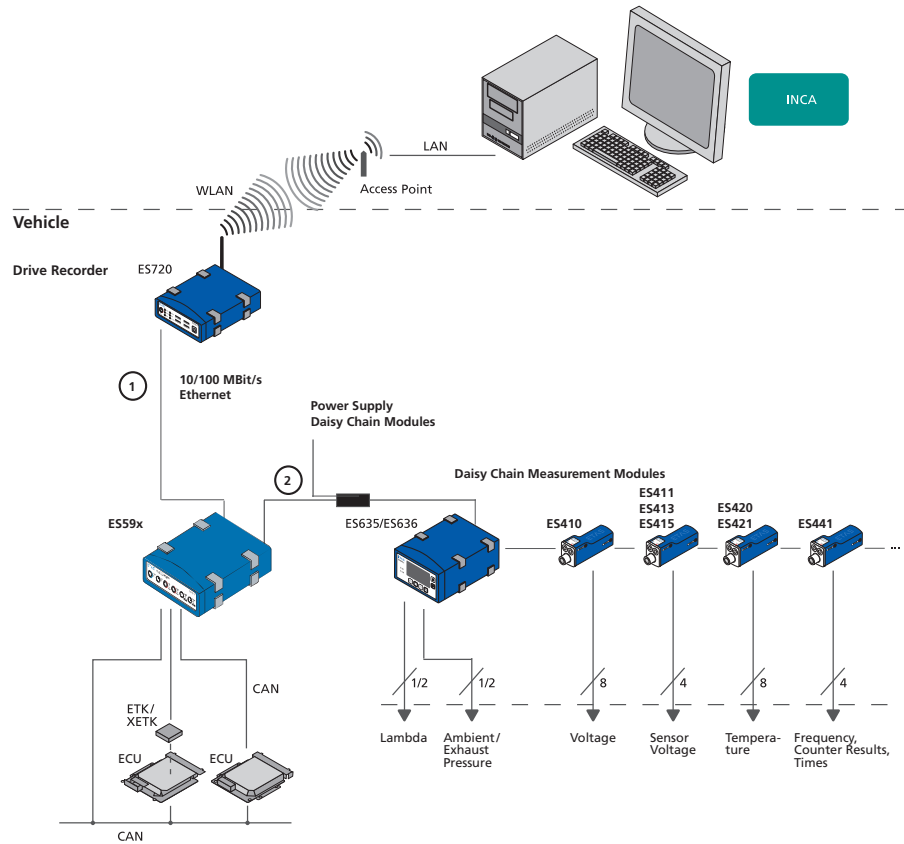

**Fig. 5-17** ES400 Modules with additional ETAS Modules and Drive Recorder (Measurement and Calibration)

Cable in Fig. 5-17	Function	Order name
1	ES520-, ES59x-, ES6xx-, ES1120- or ES1135- Ethernet cable	CBE130, CBE140
2	Power supply and Ethernet cable Daisy Chain modules	CBEP430, CBEP4305

### 5.5.3 ES400 Modules with ES910.3 (Rapid Prototyping)

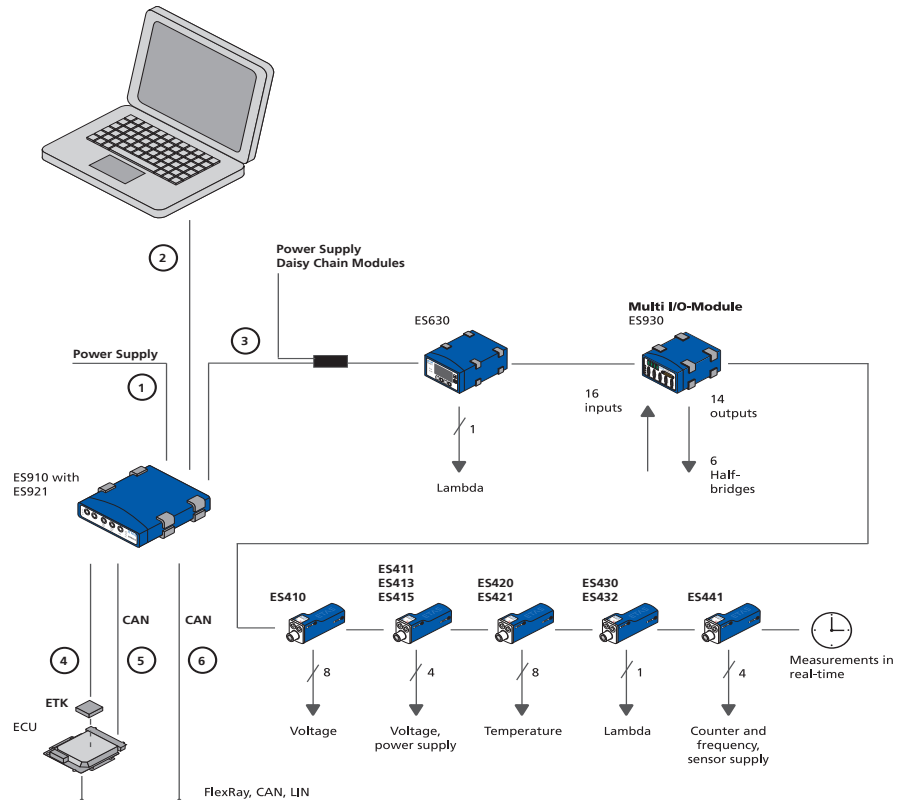

**Fig. 5-18** ES400 Modules with ES910.3 (Rapid Prototyping)

Cable in Fig. 5-18	Function	Order name
1	Power supply cable	CBP120, CBP1205
2	PC connection cable	CBE200
3	Power supply and Ethernet cable Daisy Chain modules	CBEP430, CBEP4305
4	ETK connection cable	CBM150
5, 6	CAN/LIN/FLX connection cable (CAN/LIN/FLX combined) at ES910.3, at ES921.1	CBCFI100
	CAN connection cable (CAN only), at ES910.3, at ES921.1	CBAC130, CBAC140, CBAC150, CBCX130

### 5.5.4 ES400 Modules with ES910.3 and Drive Recorder (Rapid Prototyping)

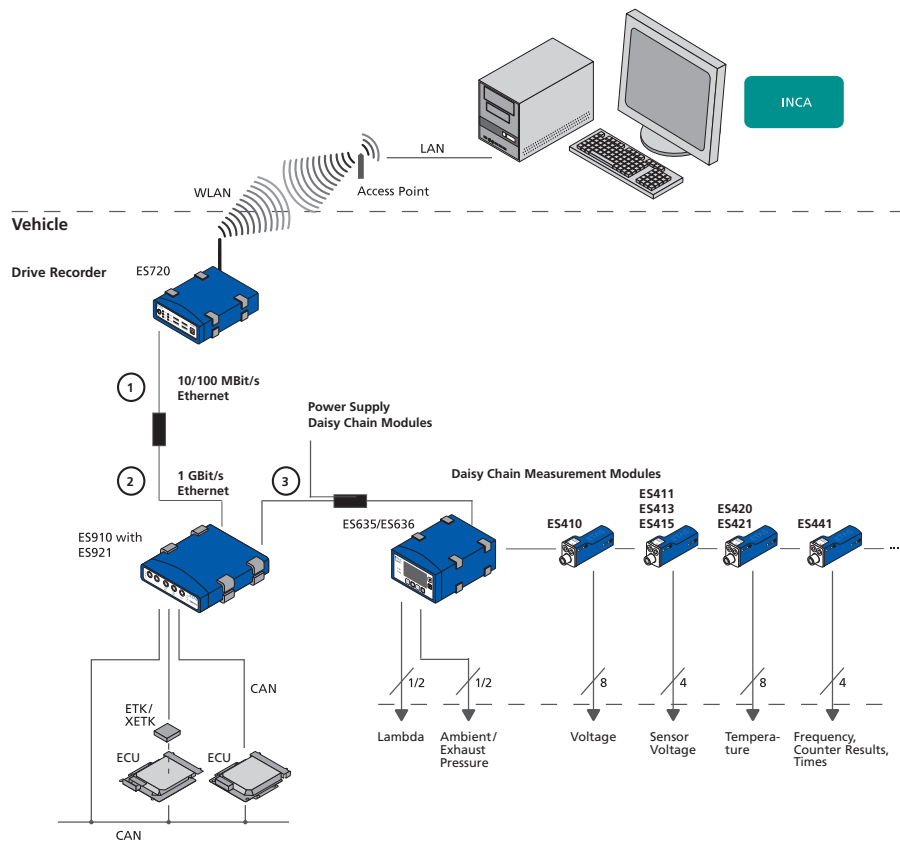

**Fig. 5-19** ES400 Modules with ES910.3 and Drive Recorder (Rapid Prototyping)

Cable in Fig. 5-19	Function	Order name
1	Ethernet adapter cable (100 Mbit/s)	CBAE330 (connected to cable 2)
2	Ethernet connection cable(1 Gbit/s)	CBE230 (connected to cable 1)
3	Power supply and Ethernet cable Daisy Chain modules	CBEP430, CBEP4305

### 5.5.5 ES400 Modules with ETAS RTPRO-PC (Rapid Prototyping)

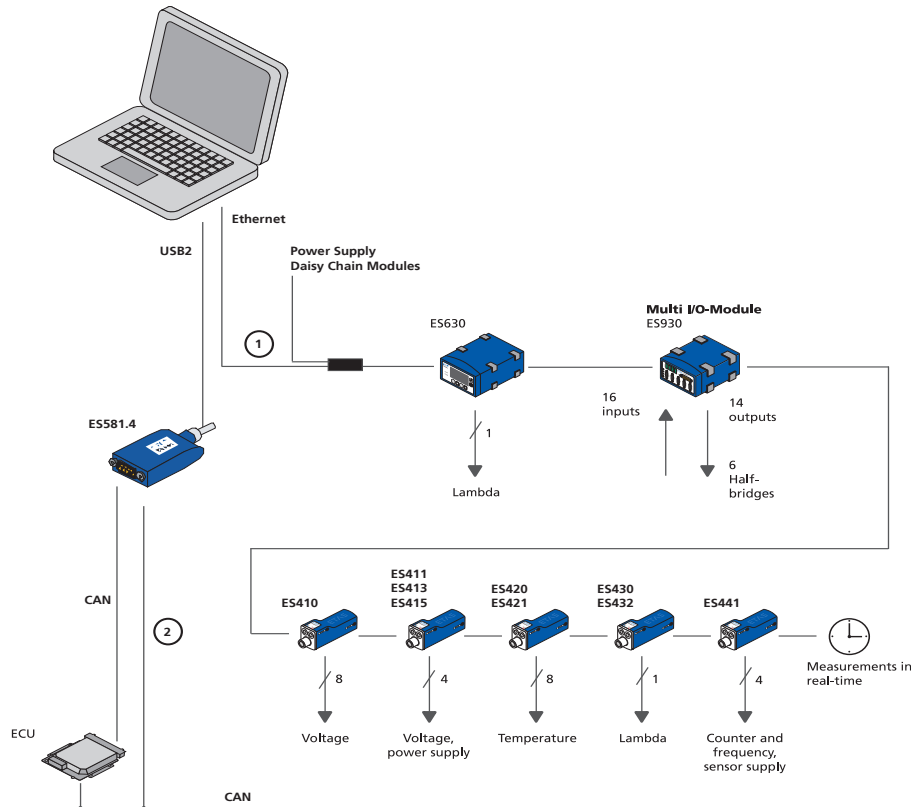

**Fig. 5-20** ES400 Modules with ETAS RTPRO-PC (Rapid Prototyping)

Cable in Fig. 5-20	Function	Order name
1	Power supply and Ethernet cable PC and Daisy Chain modules	CBEP410, CBEP4105, CBEP415, CBEP4155
2	CAN and FlexRay Y-interface cable	CBCF100

## 5.6 Wiring

The ports may be wired in any order. Special connecting cables are available and can be ordered separately. An overview is contained in the chapter “Cables and Accessories” on page 78.

### 5.6.1 “Sensor” Port

You can use different cables to connect the sensors to the ES410.1:

- CBAV480.1 sensor cable  
You can adapt the open connection of the CBAV411.1 sensor cable yourself to suit the specific connector system of your test set-up.
- CBAV401 sensor cable  
If you have swapped modules with BNC wiring for ES410.1 modules in your test set-up, this adapter cable (BNC, female) allows you to continue to use the wiring you have used to date for your test set-up.
- CBAV403 sensor cable  
If you have swapped csm AD-Scan mini modules for ES410.1 modules in your test set-up, this adapter cable (BNC, male) allows you to continue to use the wiring you have used to date for your test set-up.

#### To wire the ES410.1 with the sensors

1. If there is a protective cap at the "Sensor" port, remove it.
2. Connect the sensor cable to the “Sensor” port of the ES410.1.
3. Connect the sensors and transducers to the ports of the sensor cables of the ES410.1.
4. For your application program, jot down the assignment of the sensors to the inputs of the ES410.1 in accordance with the wiring of the test set-up.

### 5.6.2 Daisy Chain Ports (“IN”, “OUT”)

Wiring goes from the first module towards the end of the module chain.

#### To wire the first module with the following module

1. Connect an Ethernet cable to the “OUT” port of the first module.
2. Connect the Ethernet cable to the “IN” port of the next module.

or

If two modules are connected mechanically, connect their adjacent “IN” and “OUT” ports to the ES4xx\_BRIDGE.

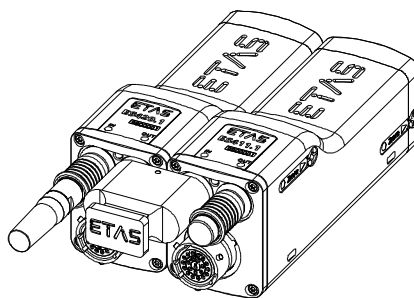

**Fig. 5-21** ES410.1 with ES4xx\_BRIDGE

**CAUTION****The ports of the modules or the ES4xx\_BRIDGE can be damaged!**

Screw the two modules together without getting them off-thread as far as it will go within the module.

3. Continue to wire or connect further modules as described above.

**To wire the first module with the PC and the power supply**

1. Connect the combined Ethernet and power supply cable to the "IN" port of the ES410.1.
2. Connect the RJ-45 connector to the free Ethernet interface port of your PC.
3. Connect the supply voltage connector of the combined Ethernet and power supply cable to the desired power supply.

Note the color coding of the connectors.

**To wire the module chain with additional current feeding**

1. End the module chain after the last module whose power supply is still guaranteed in the entire operational range.
2. Connect the combined Ethernet and power supply cable to the "OUT" port of the ES410.1 of the last module of the chain towards the PC.
3. Connect the combined Ethernet and power supply cable to the "IN" port of the ES410.1 of the next module towards the end of the chain.
4. Connect the supply voltage connector of the combined Ethernet and power supply cable to the desired power supply.

Note the color coding of the connectors.



## 6 Troubleshooting Problems

---

This chapter contains information on the following topics:

- “LED Displays” on page 57
- “Troubleshooting ES410.1 Problems” on page 57
- “Problems and Solutions” on page 59

### 6.1 LED Displays

---

Please observe the LEDs which provide information on the functions of the interface and the ES410.1 (see the chapter “LED” on page 16) to be able to judge the operational state of the ES410.1 as well as troubleshooting measures.

### 6.2 Troubleshooting ES410.1 Problems

---

The following table lists some of the possible problems with a remedy.

If you have any further questions, please contact our Customer Support (see chapter 10 on page 97).

Problem	Diagnostic Questions	Possible Solutions
The application program cannot find any ES400 modules.	Are all modules' LEDs flashing green?	Check that the function for automatic change to energy saving mode on your PC Card has been disabled <sup>1)</sup> . Disable this function.
	Did you configure the network card correctly?	INCA, Config Tool and HSP operation: Check that your network card has been configured in accordance with section 6.3 on page 59.  Stand-alone operation: Check that the IP address used belongs to your IP subnetwork and has been entered in the A2L file.
	Did you install the application software required?	Check that the application software installed on your PC corresponds to the requirements listed in section 7.9.2 on page 70.
	Power supply	Check that your power supply and test setup correspond to the requirements listed in section 4.5 on page 28.
	Is the hardware connected to the PC?	Check that the wiring is undamaged.
	Are the modules in the module chain connected correctly?	Check that the wiring is undamaged.

Problem	Diagnostic Questions	Possible Solutions
Measurement does not start.	Are you being prompted to carry out an update in the INCA-Monitorlog or in the Config-Tool?	Update the modules.
	Is there no data from the module?	Check that your power supply and test setup correspond to the requirements listed in section 4.5 on page 28. Check that the wiring of the hardware to the PC is correct/intact. Check that the modules in the module chain are connected correctly.
	You are using the ES4xx Configuration Tool and the module is supplying no data?	Check whether the position of one or more modules in the chain has changed. Check that you are not using an incorrect A2L file. Check whether you have loaded the measure configuration to the module chain. Check that you have not assigned the same IP address to two module chains.
	Is the module supplying usable data?	Check that the sensor is connected correctly.
Data is lost during data transfer.	Are you using WLAN in your test setup?	WLAN is not permissible within this ETAS network. Wire your test setup (ETAS modules and their connection to the PC) with ETAS cables only.
	Are you using the correct type of network card in your laptop?	Check whether you are using a PCMCIA network card in your laptop. PCMCIA cards with an 8- or 16-bit data bus are not suitable. Only use PCMCIA cards with a 32-bit data bus, mini-PCI or ExpressCards.
The LED is showing red.	Have you just carried out an update?	INCA users: Power on the module and then power it off again. Config-Tool users: Power on the module and then power it off again. Reload the measure configuration. If the LED continues to show red, send the module to ETAS for repair.
The firmware of one or more modules cannot be updated.	Is the module to be updated in a module chain?	Update the firmware of these ES400 modules separately.

<sup>1)</sup>: The manufacturers of PC Cards have different names for this function.  
Example: "Link down Power saving"

## 6.3 Problems and Solutions

---

### 6.3.1 Network Adapter Cannot Be Selected via Network Manager

#### Cause: APIPA is disabled

The alternative mechanism for IP addressing (APIPA) is usually enabled on all Windows 7, 8.1 and 10 systems. Network security policies, however, may request the APIPA mechanism to be disabled. In this case, you cannot use a network adapter which is configured for DHCP to access ETAS hardware. The ETAS Network Manager displays a warning message.

The APIPA mechanism can be enabled by editing the Windows registry. This is permitted only to users who have administrator privileges. It should be done only in coordination with your network administrator.

#### To enable the APIPA mechanism:

1. Open the Registry Editor:
  - Windows 7, 8.1:
    - 1.1 Click on the Windows symbol.
    - 1.2 Enter `regedit` in the entry field.
    - 1.3 Push <ENTER>.
  - Windows 10:
    - 1.1 Rightclick on the Windows symbol.
    - 1.2 Click on **Search**.
    - 1.3 Enter `regedit` in the entry field.
    - 1.4 Push <ENTER>.

The registry editor is displayed.

2. Open the folder `HKEY_LOCAL_MACHINE\SYSTEM\CurrentControlSet\Services\Tcpip\Parameters\`
3. Click **Edit** → **Find** to search for the key `IPAutoconfigurationEnabled`.

If you cannot find any instances of the registry key mentioned, the APIPA mechanism has not been disabled on your system. i.e. there is no need to enable it. Otherwise proceed with the following steps:

4. Set the value of the key `IPAutoconfigurationEnabled` to 1 to enable the APIPA mechanism.

You may find several instances of this key in the Windows registry which either apply to the TCP/IP service in general or to a specific network adapter. You only need to change the value for the corresponding network adapter.
5. Close the registry editor.
6. Restart your workstation in order to make your changes take effect.

## 6.3.2 Search for Ethernet Hardware Fails

### Cause: Personal Firewall blocks Communication

For a detailed description on problems caused by personal firewalls and possible solutions see chapter 6.3.3 on page 62.

### Cause: Client Software for Remote Access blocks Communication

PCs or notebooks which are used outside the ETAS hardware network sometimes use a client software for remote access which might block communication to the ETAS hardware. This can have the following causes:

- A firewall which is blocking Ethernet messages is being used (see „Cause: Personal Firewall blocks Communication“ on page 60)
- By mistake, the VPN client software used for tunneling filters messages. As an example, Cisco VPN clients with versions before V4.0.x in some cases erroneously filtered certain UDP broadcasts.

If this might be the case, please update the software of your VPN client.

### Cause: ETAS Hardware hangs

Occasionally the ETAS hardware might hang. In this case switch the hardware off, then switch it on again to re-initialize it.

### Cause: Network Adapter temporarily has no IP Address

Whenever you switch from a DHCP company LAN to the ETAS hardware network, it takes at least 60 seconds until ETAS hardware can be found. This is caused by the operating system's switching from the DHCP protocol to APIPA, which is being used by the ETAS hardware.

### Cause: ETAS Hardware had been connected to another Logical Network

If you use more than one PC or notebook for accessing the same ETAS hardware, the network adapters used must be configured to use the same logical network. If this is not possible, it is necessary to switch the ETAS hardware off and on again between different sessions (repowering).

### Cause: Device driver for network card not in operation

It is possible that the device driver of a network card is not running. In this case you will have to deactivate and then reactivate the network card.

#### Deactivating and reactivating the network card:

1. Open the Control Panel:
  - Windows 7, 10:
    - 1.1 Click on the Windows symbol.
    - 1.2 Click on **Control Panel**.
  - Windows 8.1:
    - 1.1 Click on the Windows symbol.
    - 1.2 Enter `Control Panel` in the entry field.
    - 1.3 Push <ENTER>.

2. Click on **Network and Sharing Center**.
3. Click on **Change adapter settings**.
4. Right click on the used network adapter.
5. Select **Deactivate** in the context menu.
6. In order to reactivate the network adapter right click on it again.
7. Select **Activate**.

### **Cause: Laptop energy management deactivates the network card**

The energy management of a laptop computer can deactivate the network card. Therefore you should turn off energy monitoring on the laptop.

#### **Switching off Energy Monitoring on Laptop**

1. Open the Control Panel:
  - Windows 7, 10:
    - 1.1 Click on the Windows symbol.
    - 1.2 Click on **Control Panel**.
  - Windows 8.1:
    - 1.1 Click on the Windows symbol.
    - 1.2 Enter `Control Panel` in the entry field.
    - 1.3 Push <ENTER>.
2. Click on **Device Manager**.
3. In the Device Manager open the tree structure of the entry **Network Adapter**.
4. Right click on the used network adapter.
5. Select **Properties** in the context menu.
6. Switch off energy monitoring as follows:
  - i. Select the **Energy Management** tab.
  - ii. Deactivate the Computer can switch off device to save energy option.
7. Select the **Extended** tab.
8. If the property **Autosense** is included, deactivate it.
9. Click **OK** to apply the settings.

### **Cause: Automatic disruption of network connection**

It is possible after a certain period of time without data traffic that the network card automatically interrupts the Ethernet connection. This can be prevented by setting the registry key `autodisconnect`.

#### **Setting the Registry Key autodisconnect:**

1. Open the Registry Editor:
  - Windows 7, 8.1:
    - 1.1 Click on the Windows symbol.
    - 1.2 Enter `regedit` in the entry field.
    - 1.3 Push <ENTER>.

- Windows 10:
  - 1.1 Rightclick on the Windows symbol.
  - 1.2 Click on **Search**.
  - 1.3 Enter `regedit` in the entry field.
  - 1.4 Push <ENTER>.
- 2. Select under `HKEY_LOCAL_MACHINE\SYSTEM\ControlSet001\Services\lanmanserver\parameters` the Registry Key `autodisconnect`.
- 3. Change its value to `0xffffffff`.

### 6.3.3 Personal Firewall Blocks Communication

#### Reason: Missing releases in the firewall block the ETAS hardware

Personal firewalls may interfere with access to ETAS Ethernet hardware. The automatic search for hardware typically cannot find any Ethernet hardware at all, although the configuration parameters are correct.

Some actions in ETAS products can lead to problems if the firewall is not properly parameterized, e.g. when opening the experiment environment in ASCET or for the hardware search by INCA or HSP.

If a firewall is blocking communication to ETAS hardware, you must either disable the firewall software while working with ETAS software, or the firewall must be configured to give the following permissions:

- Outgoing limited IP broadcasts via UDP (destination IP 255.255.255.255) for the destination port 17099 or 18001
- Incoming limited IP broadcasts via UDP (destination IP 255.255.255.255, originating from source IP 0.0.0.0) for destination port 18001
- Directed IP broadcasts via UDP to the network configured for the ETAS application, destination ports 17099 or 18001
- Outgoing IP unicasts via UDP to every IP address in the network configured for the ETAS application, destination ports 17099 to 18020
- Incoming IP unicasts via UDP originating from any IP address in the network configured for the ETAS application, originating ports 17099 to 18020, destination ports 17099 to 18020
- Outgoing TCP/IP connections to the network configured for the ETAS application, destination ports 18001 to 18020



#### NOTE

The ports to be used in a specific case depend on the hardware used. For more detailed information about the port numbers to be used, see the respective hardware documentation.

In Windows 7, 8.1 and 10, a Personal Firewall program is part of the scope of delivery and enabled by default. On many other systems, similar programs from independent providers can frequently be found, such as Symantec, McA-

fee or BlackIce. The procedure for the configuration of ports may differ in the various programs. More detailed information can be found in the user documentation of your firewall program.

Below is a sample description about how to configure the Windows firewall if the hardware access is being blocked.

## Solution for Windows Firewall, user with administrator rights

### Enabling ETAS products in the firewall control:

1. Open the Control Panel:
  - Windows 7, 10:
    - 1.1 Click on the Windows symbol.
    - 1.2 Click on **Control Panel**.
  - Windows 8.1:
    - 1.1 Click on the Windows symbol.
    - 1.2 Enter `Control Panel` in the entry field.
    - 1.3 Push <ENTER>.
2. Click on **Windows Firewall** (Win 7, 8.1) or **Windows Defender Firewall** (Win 10).



3. Click on **Allow a program / app or feature through Windows (Defender) Firewall.**

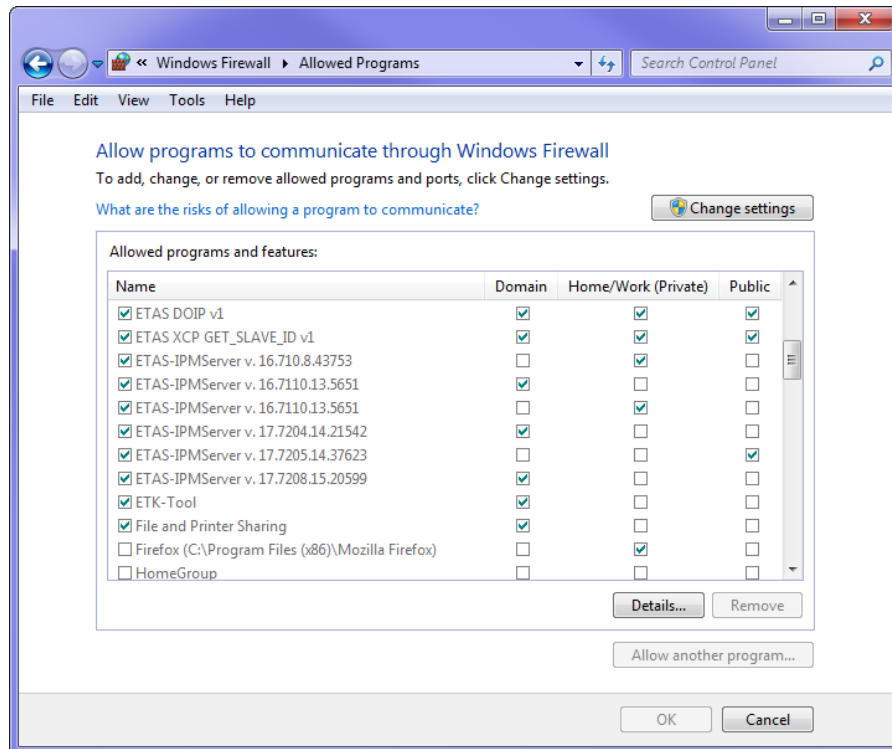

This window lists the exceptions that are not blocked by the firewall.

4. Click on **Change settings**.
5. Check the boxes to enable the respective program for the corresponding network.
6. Ensure that the ETAS products and services to be used are correctly configured exceptions.
7. Click on **OK**.
8. Close the **Windows Firewall**.

The firewall no longer blocks the ETAS product. The setting is retained after a restart of the PC.

### Solution for Windows Firewall, user without administrator rights

This chapter is directed at users with restricted rights, e.g. no changes to the system, restricted write permissions, local login.

Working with an ETAS product requires the rights "Write" and "Modify" in the directories `ETAS`, `ETASData` and the temporary ETAS directories. Otherwise, an error message appears if the product is being started and a database is being opened. A correct operation of the product is not possible since the database file as well as various `*.ini` files are modified during the work.

The ETAS software must be installed by an administrator in any case. It is recommended that the administrator ensures that the ETAS product or the processes are added to the list of selected exceptions of the Windows Firewall after the installation.



## 7 Technical Data

---

This chapter contains information on the following topics:

- "General Data" on page 65
- "RoHS Conformity" on page 68
- "CE conformity" on page 68
- "Product Return and Recycling" on page 69
- "Declarable Substances" on page 69
- "Use of Open Source Software" on page 69
- "System Requirements" on page 70
- "Electrical Data" on page 71
- "Pin Assignment" on page 75







### 7.1 General Data



---

This section contains details of the admissible environmental conditions as well as the mechanical data.

#### 7.1.1 Product Labeling

The following symbols are used for product labeling:

Symbol	Description
	Prior to operating the product, be sure to read the user's guide!
	Labeling of the daisy chain port, "IN" (input; Ethernet connection to the upstream module or the PC, power supply of the module)
	Labeling of the daisy chain port, "OUT" (output; Ethernet connection and power supply of the downstream module)
CH	Connection of sensor cable
SN: 1234567	Serial number (seven-digit)
Vx.y.z	Hardware version of the product
F 00K 123 456	Ordering number of the product, see chapter 9.1 on page 93
<b>5-50V</b>  <b>Pmax=4W</b>	Operating voltage range (DC), Power consumption
	Labeling for WEEE, see chapter 7.6 on page 69
	Marking for CE conformity (Chapter 7.3 on page 68)

Symbol	Description
	Marking for UKCA conformity (Chapter 7.4 on page 68)
	Marking for KCC conformity (Chapter 7.5 on page 68)
	Labeling for RoHS (China), see chapter on page 68

## 7.1.2

### Standards and Norms

The module adheres to the following standards and norms

Norm	Test
DIN EN 60068-2-1	Premature fatigue cold test
DIN EN 60068-2-2	Premature fatigue heat test
DIN EN 60068-2-13	Negative pressure
DIN EN 60068-2-14 Na	Temperature shock
DIN EN 60068-2-14 Nb	Temperature change: Temperature: Tu -40 °C / To +120 °C, Number of cycles: 10, Unit under test: active
DIN EN 60068-2-56	Humidity storage
DIN EN 60068-30, Variant 1	Climate change
DIN EN 60068-2-64, ISO 16750-3	Vibration, noise: 3 space axis, test duration 4 h, Unit under test: active
	In addition, the combination was tested by cascaded modules.
ISO 16750-3, Sec. 4.2.2.2	Mech. shock 3 space axis, half sinus, Acceleration: 500 m/s <sup>2</sup> , Shock duration: 6 ms, Shocks per direction and axis: 10, Units under test: active
ISO 16750-3, Sec. 4.3	Drop test Number of drops: 2, Height: 1 m, Surface: concrete, steel Units under test: passive
ISO 16750-4, Sec. 5.2	Phased temperature test

Norm	Test
ISO 16750-4, Sec. 5.4.2	Splash water Air temperature: To +120 °C, Cycle duration: 30 min, Splash length: 3 s, Splash quantity: ca. 3 l, Splash water temperatur: +2 °C ± 2 °C, Medium: water, put in 3% Arizona dust fine, Number of cycles: 100, Unit under test: active
ISO 16750-4, Sec. 5.5.1.; DIN EN 60068-2-52	Salt fog: Severity level: 5, Test duration: 16 d, Units under test: passive
ISO 16750-5	Chemical resistance: Identification A-W, Prüflinge passiv
DIN 5596-1	Stone impact
IPX7	Protection class test: Protection class IP67
IEC61326-1	Electrical equipment for measurement, control and laboratory use - EMC requirements (Industrial Environments)
DIN EN 55022	Emission radiation/ radio interference voltage

### 7.1.3 Environmental Conditions

Operating temperature range	-40 °C to +120 °C -40 °F to +248 °F
Storage temperature range (module without packaging)	-40 °C to +125 °C -40 °F to +257 °F
Implementation altitude	max. 5,000 m / 16,400 ft
Protection class	IP67



#### **CAUTION**

##### **Loss of Features as defined by IP67!**

Do not open or change the module housing!

Works on the module housing may be executed only by qualified technical personnel.

### 7.1.4 Maintenance the Product

Do not open or change the module! Works on the module housing may be executed only by qualified technical personnel. Send defect modules to ETAS.

### 7.1.5 Cleaning the Product

We recommend to clean the product with a dry cloth.

### 7.1.6 Mechanical Data

Dimensions (H x W x D)	51.5 mm x 40 mm x 139 mm / 37.5 mm x 40 mm x 124 mm
	2.0 in x 1.57 in x 5.47 in 1.48 in x 1.57 in x 4.88 in
Weight	350 g / 0.77 lb

### 7.1.7 Modules in One Chain

Modules in chain	Max. 254 in one chain
------------------	-----------------------

## 7.2 RoHS Conformity

### European Union

The EU Directive 2011/65/EU limits the use of certain dangerous materials for electric and electronic devices (RoHS conformity).

ETAS confirms that the product meets this directive applicable in the European Union.

### China

ETAS confirms that the product meets the "China RoHS" (Management Methods for Controlling Pollution Caused by Electronic Information Products Regulation) guidelines applicable to the People's Republic of China with a China RoHS label attached to the product or its packaging.

## 7.3 CE conformity

With the CE mark attached to the product or its packaging, ETAS confirms that the product corresponds to the product-specific, applicable directives of the European Union.

The CE Declaration of Conformity for the product is available upon request.

## 7.4 UKCA conformity

With the UKCA mark attached to the product or its packaging, ETAS confirms that the product corresponds to the product-specific, applicable standards and directives of Great Britain.

The UKCA declaration of conformity for the product is available on request.

## 7.5 KCC conformity

With the KC mark attached to the product and its packaging, ETAS confirms that the product has been registered in accordance with the product-specific KCC guidelines of the Republic of Korea.

## 7.6 Product Return and Recycling

---

The European Union (EU) has issued the guideline on waste electric and electronic equipment (Waste Electrical and Electronic Equipment - WEEE) in order to ensure the institution of systems for collection, handling, and disposal of all electronic scrap.

This ensures that the devices are recycled in a resource-friendly way that does not represent any risk to personal health and the environment.



**Fig. 7-1** WEEE symbol

The WEEE symbol (see Fig. 7-1 on page 69) on the product or its packaging identifies that the product may not be disposed of together with the remaining trash.

The user is obligated to separate the waste equipment and to provide it to the WEEE return system for reuse.

The WEEE Directive applies to all ETAS devices, but not to external cables or batteries.

Additional information about the recycling program of ETAS GmbH is available from the ETAS sales and service locations (see chapter 10 on page 97).

## 7.7 Declarable Substances

---

### European Union

Some products from ETAS GmbH (e.g. modules, boards, cables) use components with substances that are subject to declaration in accordance with the REACH regulation (EU) no.1907/2006.

Detailed information is located in the ETAS download center in the customer information "REACH Declaration" ([www.etas.com/Reach](http://www.etas.com/Reach)). This information is continuously being updated.

## 7.8 Use of Open Source Software

---

The product uses Open Source Software (OSS). This software is installed in the product at the time of delivery and does not have to be installed or updated by the user. Reference shall be made to the use of the software in order to fulfill OSS licensing terms. Additional information is available in the document "OSS Attributions List" at the ETAS website [www.etas.com](http://www.etas.com).

## 7.9 System Requirements

---

### 7.9.1 Hardware

#### Power supply

Operation of the modules requires a power supply voltage of 5 V to 50 V/ 6 V to 50 V DC.

#### PC with one Ethernet interface

A PC with one open Ethernet interface (100 Mbit/s, full duplex) with RJ-45 connection is required.

#### Requirement to ensure successful initialization of the module

 **NOTE**

It is imperative you disable the function which automatically switches to power-saving mode on your PC network adapter when there is no data traffic on the Ethernet interface!

#### To deactivate the power saving mode

Choose in System Control Center / Device Manager / Network Adapter the used network adapter by double-click. Deactivate the "Allow the computer to turn off this device to save power" option in the "Power Management" register. Confirm your configuration.

The manufacturers of network adapter have different names for this function.

Example:

- "Link down Power saving"
- "Allow the computer to turn off this device to save power".

### 7.9.2 Software

To configure the ES410.1 and for control and data acquisition, you need software in the following versions:

- INCA V5.4.1 with Add-On 1.0.7 and higher  
or
- ES4xx Configuration Tool V1.0.7 from ES4xx\_DRV\_SW (stand-alone operation)  
or
- Integration into software not based on XCP-on-Ethernet via a C-based library.

 **NOTE**

Operating the ES410.1 with older versions of software is not possible.

## 7.10 Electrical Data

This chapter contains information on the following topics:

- "Host Interface" on page 71
- "Power Supply" on page 72
- "Sensor Inputs" on page 72
- "Signal Processing" on page 74.

### NOTE

ETAS guarantees measurement accuracy of the ES410.1 for one year. Please use our calibration service (see section 4.9 on page 31)!

### NOTE

Unless otherwise specified, all data applies at 25 °C.

### 7.10.1 Host Interface

Connection	100Base-T Ethernet; 100 Mbit/s, Full Duplex PC Card 32-bit
Protocol	XCP on UDP/IP
IP address	Dynamic via INCA or via ES4xx Configuration Tool from ES4xx_DRV_SW (stand-alone operation)

### NOTE

For the successful initialization of the network card of your PC, observe chapter 7.9.1 on page 70.

### 7.10.2 Power Supply

Operating voltage	Temperature range -40 °C to +85 °C: 5 V to 50 V DC
	Temperature range -40 °C to +120 °C: 6 V to 50 V DC
Power consumption (operation, room temperature)	Max. 2.1 W at 13.5 V DC
Power consumption (standby, room temperature)	Typ. 25 mW at 13.5 V DC
Polarity inversion protection, load dump protection <sup>1)</sup>	With CBEP410, CBEP4105, CBEP415, CBEP4155, CBEP420, CBEP4205, CBEP425, CBEP4255, CBEP430, CBEP4305 cable
Overvoltage category (AC mains supply)	II

<sup>1)</sup>: The module may be used only with central load dump protection.

### 7.10.3 Sensor Inputs

#### Features

Input channels	8, galvanically isolated
A/D converter	One A/D converter per channel, 16-bit resolution
Hardware input filter	Low-pass 4th order, Butterworth, cutoff frequency 10 kHz
Sampling rate of application tool	0.5 to 10000 samples/s, can be configured individually for each channel
Input voltage ranges	-100 mV to +100 mV -1 V to +1 V -10 V to +10 V -60 V to +60 V
Maximum input voltage (dry environment)	Input-to-input: 60 V DC / 30 V AC Input-to-ground of voltage supply or housing: 60 V DC / 30 V AC
Maximum Input voltage (wet environment)	Input-to-input: 35 V DC / 16 V AC Input-to-ground of voltage supply or housing: 35 V DC / 16 V AC



## Characteristics

Maximum input voltage resolution (16-bit)	±100 mV measurement range: 3.6 $\mu$ V
	±1 V measurement range: 37.2 $\mu$ V
	±10 V measurement range: 366 $\mu$ V
	±60 V measurement range: 2.16 mV
Maximum measurement error	±100 mV measurement range ( $ U_{IN} $ in $\mu$ V): $\pm(150 \mu\text{V} +  U_{IN}  * 0.12\%)$
	±1 V measurement range: ( $ U_{IN} $ in $\mu$ V): $\pm(500 \mu\text{V} +  U_{IN}  * 0.1\%)$
	±10 V measurement range: ( $ U_{IN} $ in mV): $\pm(3 \text{ mV} +  U_{IN}  * 0.1\%)$
	±60 V measurement range: ( $ U_{IN} $ in mV): $\pm(16 \text{ mV} +  U_{IN}  * 0.22\%)$
Max. voltage drift (temperature), temperature range -40 °C to +85 °C	±100 mV measurement range: 10 $\mu$ V/K
	±1 V measurement range: 10 $\mu$ V/K
	±10 V measurement range: 50 $\mu$ V/K
	±60 V measurement range: 3.6 mV/K
Max. voltage drift (temperature), temperature range +85 °C to +120 °C	±100 mV measurement range: 150 $\mu$ V/K
	±1 V measurement range: 150 $\mu$ V/K
	±10 V measurement range: 150 $\mu$ V/K
	±60 V measurement range: 3.6 mV/K
Input impedance	Measurement ranges $\pm 100 \text{ mV}$ , $\pm 1 \text{ V}$ : > 10 M $\Omega$    < 2 nF
	Measurement ranges $\pm 10 \text{ V}$ , $\pm 60 \text{ V}$ : > 2 M $\Omega$    < 2 nF
	Module not powered: > 2 M $\Omega$    < 2 nF

## 7.10.4 Signal Processing

### Features

Resolution	16 Bit, increased with slow sampling rates
Sampling rate	0.5 to 10000 samples/s, can be configured individually for each channel
Hardware input filter	Low-pass 4th order, Cutoff frequency 10 kHz, max. overshoot 3%
Digital low-pass filter	Butterworth low-pass filter 8th order with adjustable cutoff frequency, realized as FIR filter, can be disabled
	Automatic: 0.4 * sampling rate
	Manual: see table "Characteristics"

### Characteristics

Sam- pling Rate	Sam- pling Time	$f_{C,FIR}$				
		Auto- Filter	Filter 2	Filter 3	Filter 4	Filter 5
10 kHz	100 $\mu$ s	4 kHz	2 kHz	800 Hz	400 Hz	200 Hz
5 kHz	200 $\mu$ s	2 kHz	800 Hz	400 Hz	200 Hz	80 Hz
2 kHz	500 $\mu$ s	800 Hz	400 Hz	200 Hz	80 Hz	40 Hz
1 kHz	1 ms	400 Hz	200 Hz	80 Hz	40 Hz	20 Hz
500 Hz	2 ms	200 Hz	80 Hz	40 Hz	20 Hz	8 Hz
200 Hz	5 ms	80 Hz	40 Hz	20 Hz	8 Hz	4 Hz
100 Hz	10 ms	40 Hz	20 Hz	8 Hz	4 Hz	2 Hz
50 Hz	20 ms	20 Hz	8 Hz	4 Hz	2 Hz	0.8 Hz
20 Hz	50 ms	8 Hz	4 Hz	2 Hz	0.8 Hz	0.4 Hz
10 Hz	100 ms	4 Hz	2 Hz	0.8 Hz	0.4 Hz	0.2 Hz
5 Hz	200 ms	2 Hz	0.8 Hz	0.4 Hz	0.2 Hz	
2 Hz	500 ms	0.8 Hz	0.4 Hz	0.2 Hz		
1 Hz	1 s	0.4 Hz	0.2 Hz			
0.5 Hz	2 s	0.2 Hz				

## 7.11 Pin Assignment

This chapter contains information on the following topics:

- “IN” Connector” on page 75
- “OUT” Connector” on page 76
- “Sensor” Connector” on page 77

### NOTE

All connectors are shown with a view of the front of the ES410.1.  
All shields are at case potential.

### 7.11.1 “IN” Connector

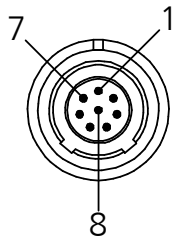

**Fig. 7-2** “IN” Connector

Pin	Signal	Meaning
1	UBatt	Operating voltage
2	Ground	Ground
3	RX-	Received data, minus
4	TX-	Send data, minus
5	RX+	Received data, plus
6	Ground	Ground
7	UBatt	Operating voltage
8	TX+	Send data, plus

The following plug is mounted on "IN" connector:

LEMO 1B 8-pin L-coding (connection identified in green)

### 7.11.2 "OUT" Connector

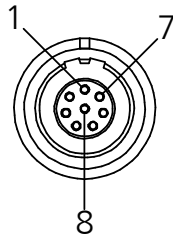

**Fig. 7-3** "OUT" Connector

Pin	Signal	Meaning
1	UBatt	Operating voltage
2	UBatt	Operating voltage
3	Ground	Ground
4	RX+	Received data, plus
5	TX-	Send data, minus
6	RX-	Received data, minus
7	Ground	Ground
8	TX+	Send data, plus

The following socket is mounted on "OUT" connector:

LEMO 1B 8-pin A-coding (connection identified in yellow)

## 7.11.3 "Sensor" Connector

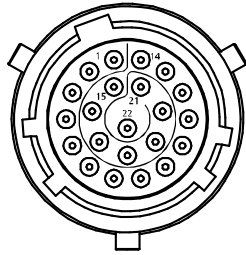

Fig. 7-4 "Sensor" Connector

Pin	Signal	Meaning
1	CH3 In-	Measurement channel 3, input minus
2	CH4 In+	Measurement channel 4, input plus
3	CH4 In-	Measurement channel 4, input minus
4	CH8 In-	Measurement channel 8, input minus
5	CH8 In+	Measurement channel 8, input plus
6	CH7 In-	Measurement channel 7, input minus
7	CH7 In+	Measurement channel 7, input plus
8	CH6 In-	Measurement channel 6, input minus
9	CH6 In+	Measurement channel 6, input plus
10	CH5 In-	Measurement channel 5, input minus
11	CH5 In+	Measurement channel 5, input plus
12	CH1 In+	Measurement channel 1, input plus
13	CH1 In-	Measurement channel 1, input minus
14	CH2 In-	Measurement channel 2, input minus
15	CH3 In+	Measurement channel 3, input plus
16	-	Reserved
17	-	Reserved
18	TEDS+	Cable, TEDS+
19	-	Reserved
20	-	Reserved
21	CH2 In+	Measurement channel 2, input plus
22	TEDS-	Cable, TEDS-

## 8 Cables and Accessories

---

This chapter contains information on the following topics:

- "Combined Ethernet and Power Supply Cable" on page 79
- "Ethernet Cable" on page 85
- "Cables for the Connector "Sensor"" on page 88
- "Protective Caps" on page 91
- "Angle Brackets" on page 92



### **NOTE**

---

Only use ETAS cables at the interfaces of the module. Adhere to the maximum cable lengths!

## 8.1 Combined Ethernet and Power Supply Cable

This chapter contains information on the following cables:

- "CBEP410.1 Cable" on page 80
- "CBEP4105.1 Cable" on page 80
- "CBEP415.1 Cable" on page 81
- "CBEP4155.1 Cable" on page 81
- "CBEP420.1 Cable" on page 82
- "CBEP4205.1 Cable" on page 82
- "CBEP425.1 Cable" on page 83
- "CBEP4255.1 Cable" on page 83
- "CBEP430.1 Cable" on page 84
- "CBEP4305.1 Cable" on page 84

### 8.1.1 Overview



#### **DANGER**

##### **Dangerous electrical voltage!**

Connect the power cable only with a suitable vehicle battery or with a suitable lab power supply! The connection to power outlets is not allowed!

To prevent an inadvertent insertion in power outlets, ETAS recommends to equip the combined ethernet and power supply cables with safety banana plugs in areas with power outlets.

You can use combined ethernet and power supply cables with standard banana plugs or with safety banana plugs:

Cables with standard banana plugs	Cables with safety banana plugs
CBEP410.1	CBEP4105.1
CBEP415.1	CBEP4155.1
CBEP420.1	CBEP4205.1
CBEP425.1	CBEP4255.1
CBEP430.1	CBEP4305.1

### 8.1.2 CBEP410.1 Cable

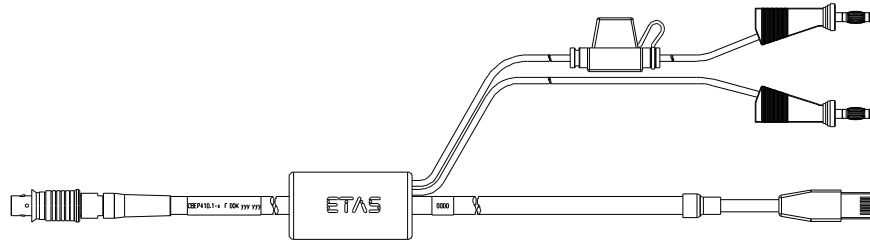

**Fig. 8-1** CBEP410.1 Cable

Connection of an ES4xx/ES63x/ES93x module to PC and power supply (stand-alone operation). Supply battery in the vicinity of the module.

Not compatible with ES610, ES611, ES620 and ES650. For connecting this modules use CBEP120 cable.

Cable includes reverse-polarity, load-dump protection and replaceable standard fuse (MINI flat automotive fuse, quick-response, 3 A, 58 V).

Robust, waterproof and dust-proof (IP67).

Temperature rated for: -40 °C to +125 °C / -40 °F to +257 °F

Product	Length	Order number
CBEP410.1-3	3 m	F 00K 104 927

### 8.1.3 CBEP4105.1 Cable

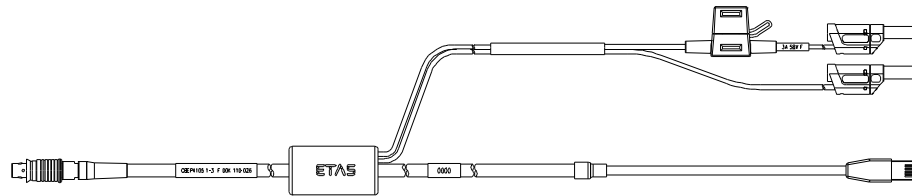

**Fig. 8-2** CBEP4105.1 Cable

Connection of an ES4xx/ES63x/ES93x module to PC and power supply (stand-alone operation). Supply battery in the vicinity of the module.

Not compatible with ES610, ES611, ES620 and ES650. For connecting this modules use CBEP120 cable.

Cable includes reverse-polarity, load-dump protection and replaceable standard fuse (MINI flat automotive fuse, quick-response, 3 A, 58 V).

Robust, waterproof and dust-proof (IP67).

Temperature rated for: -40 °C to +125 °C / -40 °F to +257 °F

Product	Length	Order number
CBEP4105.1-3	3 m	F 00K 110 026



### 8.1.4 CBEP415.1 Cable

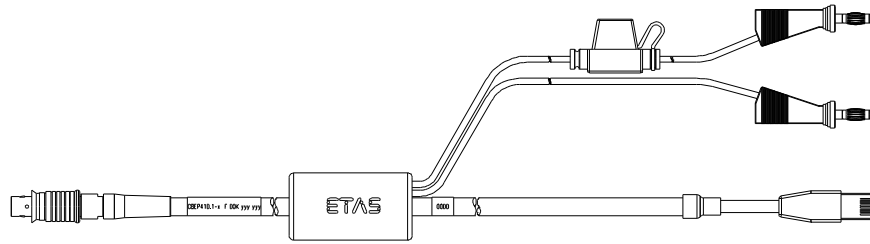

**Fig. 8-3** CBEP415.1 Cable

Connection of an ES4xx/ES63x/ES93x module to PC and power supply (stand-alone operation). Supply battery at the other end (i.e. in the trunk).

Not compatible with ES610, ES611, ES620 and ES650. For connecting this modules use CBEP120 cable.

Cable includes reverse-polarity, load-dump protection and replaceable standard fuse (MINI flat automotive fuse, quick-response, 3 A, 58 V).

Robust, waterproof and dust-proof (IP67).

Temperature rated for: -40 °C to +125 °C / -40 °F to +257 °F

Product	Length	Order number
CBEP415.1-5	5 m	F 00K 105 680

### 8.1.5 CBEP4155.1 Cable

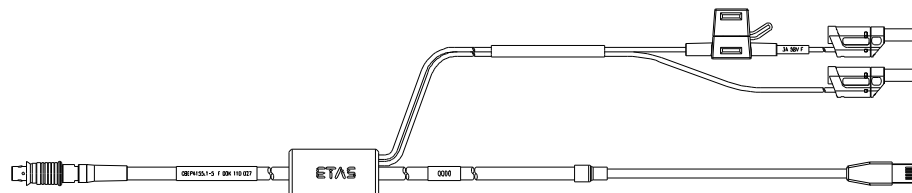

**Fig. 8-4** CBEP4155.1 Cable

Connection of an ES4xx/ES63x/ES93x module to PC and power supply (stand-alone operation). Supply battery at the other end (i.e. in the trunk).

Not compatible with ES610, ES611, ES620 and ES650. For connecting this modules use CBEP120 cable.

Cable includes reverse-polarity, load-dump protection and replaceable standard fuse (MINI flat automotive fuse, quick-response, 3 A, 58 V).

Robust, waterproof and dust-proof (IP67).

Temperature rated for: -40 °C to +125 °C / -40 °F to +257 °F

Product	Length	Order number
CBEP4155.1-5	5 m	F 00K 110 027

### 8.1.6 CBEP420.1 Cable

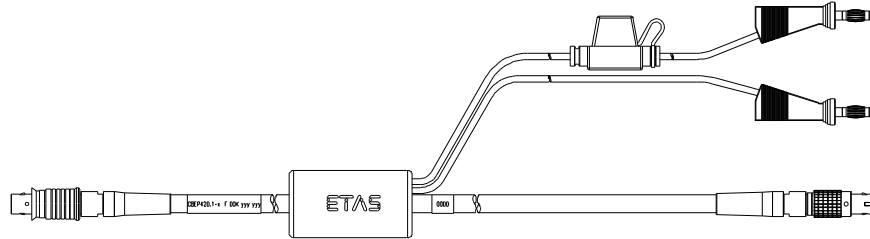

**Fig. 8-5** CBEP420.1 Cable

Ethernet and voltage supply connection of an ES4xx/ES63x/ES93x measurement module with an ES600 network module or ES592/ES593-D/ES595 interface module (if the current consumption of the connected ES4xx/ES63x chain exceeds 2.5 A), an ES1135 simulation/system controller card or an ES720 Drive Recorder.

Not compatible with ES610, ES611, ES620 and ES650. For connecting this modules use CBEP120 cable.

Cable includes reverse-polarity, load-dump protection and replaceable standard fuse (MINI flat automotive fuse, quick-response, 3 A, 58 V).

Robust, waterproof and dust-proof (IP67).

Temperature rated for: -40 °C to +125 °C / -40 °F to +257 °F

Product	Length	Order number
CBEP420.1-3	3 m	F 00K 105 292

### 8.1.7 CBEP4205.1 Cable

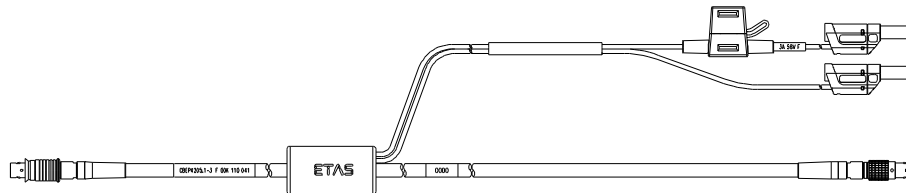

**Fig. 8-6** CBEP4205.1 Cable

Ethernet and voltage supply connection of an ES4xx/ES63x/ES93x measurement module with an ES600 network module or ES592/ES593-D/ES595 interface module (if the current consumption of the connected ES4xx/ES63x chain exceeds 2.5 A), an ES1135 simulation/system controller card or an ES720 Drive Recorder.

Not compatible with ES610, ES611, ES620 and ES650. For connecting this modules use CBEP120 cable.

Cable includes reverse-polarity, load-dump protection and replaceable standard fuse (MINI flat automotive fuse, quick-response, 3 A, 58 V).

Robust, waterproof and dust-proof (IP67).

Temperature rated for: -40 °C to +125 °C/ -40 °F to +257 °F

Product	Length	Order number
CBEP4205.1-3	3 m	F 00K 110 041

### 8.1.8 CBEP425.1 Cable

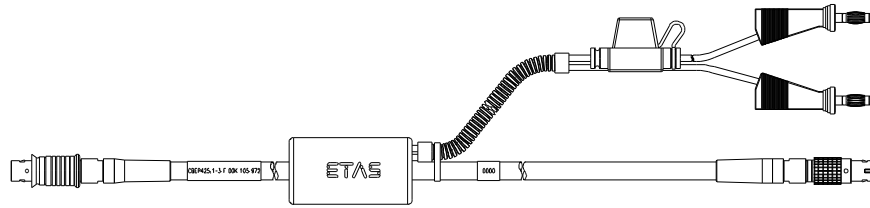

**Fig. 8-7** CBEP425.1 Cable

Ethernet and voltage supply connection of an ES4xx/ES63x/ES93x measurement module with an ES600 network module or ES592/ES593-D/ES595 interface module (if the current consumption of the connected ES4xx/ES63x/ES93x chain exceeds 2.5 A), an ES1135 simulation/system controller card or an ES720 Drive Recorder.

Cable includes reverse-polarity, load-dump protection and replaceable standard fuse (MINI flat automotive fuse, quick-response, 3 A, 58 V).

Robust, waterproof and dust-proof (IP67).

Temperature rated for: -40 °C to +125 °C / -40 °F to +257 °F

Product	Length	Order number
CBEP425.1-3	3 m	F 00K 105 972

### 8.1.9 CBEP4255.1 Cable

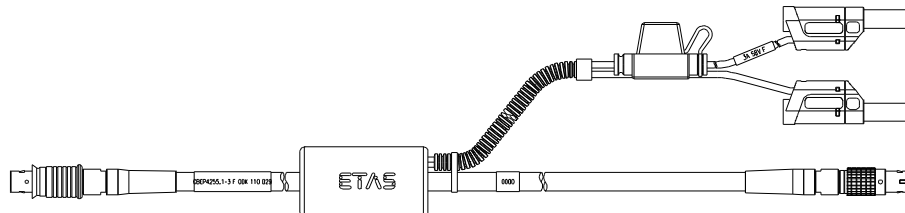

**Fig. 8-8** CBEP4255.1 Cable

Ethernet and voltage supply connection of an ES4xx/ES63x/ES93x measurement module with an ES600 network module or ES592/ES593-D/ES595 interface module (if the current consumption of the connected ES4xx/ES63x/ES93x chain exceeds 2.5 A), an ES1135 simulation/system controller card or an ES720 Drive Recorder.

Cable includes reverse-polarity, load-dump protection and replaceable standard fuse (MINI flat automotive fuse, quick-response, 3 A, 58 V).

Robust, waterproof and dust-proof (IP67).

Temperature rated for: -40 °C to +125 °C / -40 °F to +257 °F

Product	Length	Order number
CBEP4255.1-3	3 m	F 00K 110 029

### 8.1.10 CBEP430.1 Cable

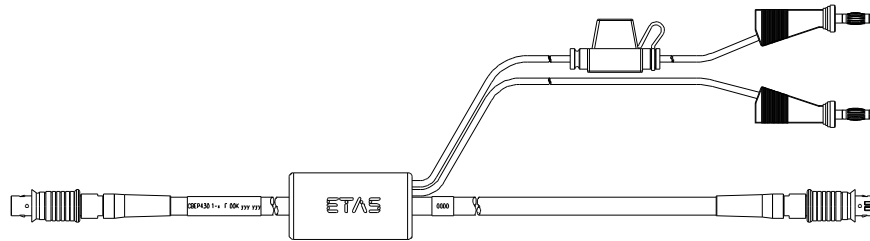

**Fig. 8-9** CBEP430.1 Cable

To chain ES4xx/ES63x/ES93x modules and connect an ES4xx/ES63x/ES93x chain to an ES910.3 Rapid Prototyping module. Additional connection to the power supply to compensate for voltage losses in long chains.

Not compatible with ES59x, ES6xx, ES11xx. For connecting this modules use CBE130 or CBE140 cable.

Cable includes reverse-polarity, load-dump protection and replaceable standard fuse (MINI flat automotive fuse, quick-response, 3 A, 58 V).

Robust, waterproof and dust-proof (IP67).

Temperature rated for: -40 °C to +125 °C / -40 °F to +257 °F

Product	Length	Order number
CBEP430.1-0m5	0.5 m	F 00K 104 928

### 8.1.11 CBEP4305.1 Cable

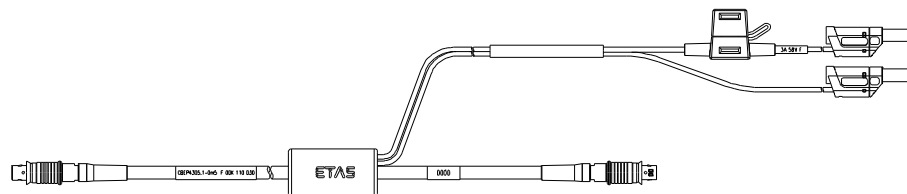

**Fig. 8-10** CBEP4305.1 Cable

To chain ES4xx/ES63x/ES93x modules and connect an ES4xx/ES63x/ES93x chain to an ES910.3 Rapid Prototyping module. Additional connection to the power supply to compensate for voltage losses in long chains.

Not compatible with ES59x, ES6xx, ES11xx. For connecting this modules use CBE130 or CBE140 cable.

Cable includes reverse-polarity, load-dump protection and replaceable standard fuse (MINI flat automotive fuse, quick-response, 3 A, 58 V).

Robust, waterproof and dust-proof (IP67).

Temperature rated for: -40 °C to +125 °C / -40 °F to +257 °F

Product	Length	Order number
CBEP4305.1-0m5	0.5 m	F 00K 110 030

## 8.2 Ethernet Cable

This chapter contains information on the following cables:

- "CBE400.2 Cable" on page 85
- "CBE401.1 Cable" on page 85
- "CBE430.1 Cable" on page 86
- "CBE431.1 Cable" on page 86
- "CBEX400.1 Cable" on page 86
- "ES4xx\_BRIDGE" on page 87

### 8.2.1 CBE400.2 Cable



**Fig. 8-11** CBE400.2 Cable

Ethernet and voltage supply connection of an ES4xx/ES63x/ES93x measuring module at an ES600 network module or at an ES592/ES593-D/ES595 interface module.

Cable includes reverse-polarity, load-dump protection and replaceable standard fuse (MINI flat automotive fuse, quick-response, 3 A, 58 V).

Robust, waterproof and dust-proof (IP67).

Temperature rated for: -40 °C to +125 °C / -40 °F to +257 °F

Product	Length	Order number
CBE400.2-3	3 m	F 00K 104 920

### 8.2.2 CBE401.1 Cable

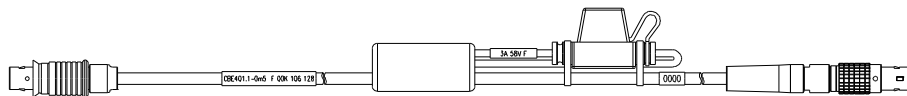

**Fig. 8-12** CBE401.1 Cable

Highly flexible Ethernet and voltage supply connection of an ES4xx/ES63x/ES93x measuring module at an ES600 network module or at an ES592/ES593-D/ES595 interface module.

Cable includes reverse-polarity, load-dump protection and replaceable standard fuse (MINI flat automotive fuse, quick-response, 3 A, 58 V).

Robust, waterproof and dust-proof (IP67).

Temperature rated for: -40 °C to +125 °C / -40 °F to +257 °F

Product	Length	Order number
CBE401.1-0m5	0.5 m	F 00K 106 128

### 8.2.3 CBE430.1 Cable

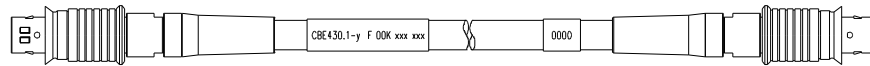

**Fig. 8-13** CBE430.1 Cable

Cable for chaining ES4xx/ES63x/ES93x modules. Not compatible with ES59x, ES6xx, ES11xx. For connecting this modules use CBE130 or CBE140 cable.

Robust, waterproof and dust-proof (IP67).

Temperature rated for: -40 °C to +125 °C / -40 °F to +257 °F

Product	Length	Order number
CBE430.1-0m45	0.45 m	F 00K 104 923

### 8.2.4 CBE431.1 Cable

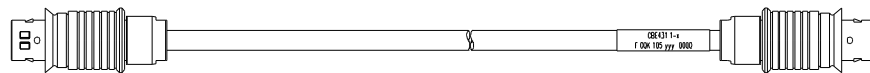

**Fig. 8-14** CBE431.1 Cable

Highly flexible cable for chaining successive ES4xx/ES63x/ES93x modules.

Not compatible with ES59x, ES6xx, ES11xx. For connecting this modules use CBE130 or CBE140 cable.

Robust, waterproof and dust-proof (IP67).

Temperature rated for: -40 °C to +125 °C / -40 °F to +257 °F

Product	Length	Order number
CBE431.1-0m14	0.14 m	F 00K 105 676
CBE431.1-0m30	0.30 m	F 00K 105 685

### 8.2.5 CBEX400.1 Cable

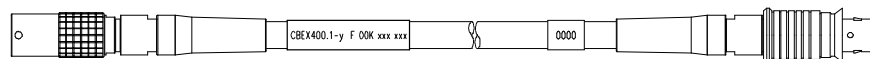

**Fig. 8-15** CBEX400.1 Cable

Ethernet extension cable to increase the length of ES4xx/ES63x/ES93x Ethernet cables. Can also be used to connect ES4xx via PC, ES600 or ES1135 alternatively while keeping cable installation through bulkhead.

Robust, waterproof and dust-proof (IP67).

Temperature rated for: -40 °C to +125 °C / -40 °F to +257 °F

Product	Length	Order number
CBEX400.1-3	3 m	F 00K 105 294

## 8.2.6 ES4xx\_BRIDGE

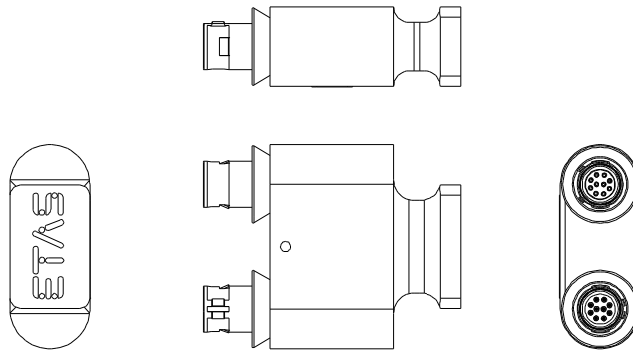

**Fig. 8-16** ES4xx Bridge

Ethernet bridge connecting blocked ES400 modules. Facilitates very compact measurement setups. IP67 compliant.

Product	Order number
ES4xx_BRIDGE	F 00K 105 684

## 8.3 Cables for the Connector "Sensor"

### 8.3.1 CBAV401.1 Cable

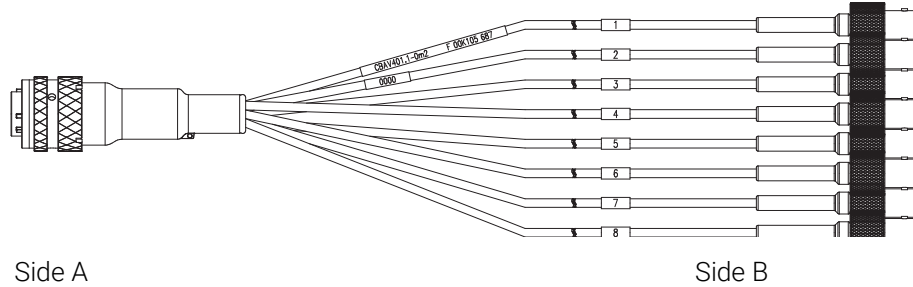

**Fig. 8-17** CBAV401.1 Cable

The CBAV401.1 cable consists of eight identical cable sections, marked n=1 to n=8. Each cable section is assigned to an ES4xx measurement channel [n] and wired according to the same scheme

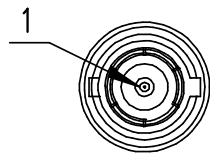

**Fig. 8-18** Connection „Sensor“ (one Cable Section)

The assignment of the connections of the BNC connector of a cable section to the signals of a measurement channel [n] is shown in the table.

Pin	Signal	Meaning
1 (inside)	CH[n] In+	Measurement channel [n], input (+)
Outside	CH[n] In-	Measurement channel [n], input (-)

#### Notes about the Application

If you replaced modules with BNC cabling with ES4xx modules in your measuring setup, the use of these adapter cables enables you to continue using the existing cabling of your measuring setup.

Temperature rated for: -40 °C to +125 °C

Product	Length	Order Number
CBAV401.1-0m2	0.2 m	F 00K 105 687



### 8.3.2 CBAV403.1 Cable

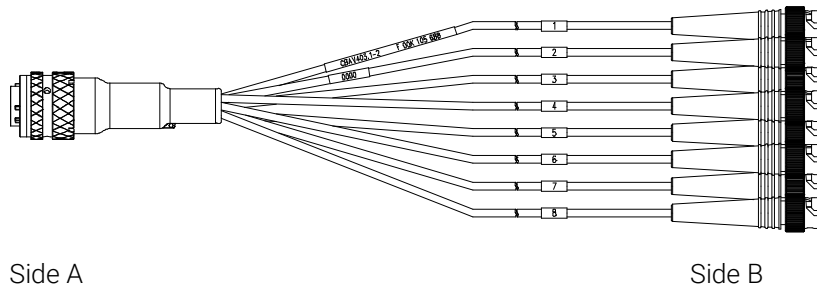

**Fig. 8-19** CBAV403.1 Cable

The CBAV403.1 cable consists of eight identical cable sections, marked n=1 to n=8. Each cable section is assigned to an ES4xx measurement channel [n] and wired according to the same scheme.

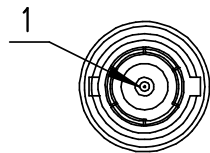

**Fig. 8-20** Connection „Sensor“ (one Cable Section)

The assignment of the connections of the BNC plug of a cable section to the signals of a measurement channel [n] is shown in the table.

Pin	Signal	Meaning
1 (inside)	CH[n] In+	Measurement channel [n], input (+)
Outside	CH[n] In-	Measurement channel [n], input (-)

#### Notes about the Application

If you replaced modules with BNC cabling with ES4xx modules in your measuring setup, the use of these adapter cables enables you to continue using the existing cabling of your measuring setup.

Temperature rated for: -40 °C to +125 °C

Product	Length	Order Number
CBAV403.1-2	2 m	F 00K 105 688

### 8.3.3 CBAV480.1 Cable

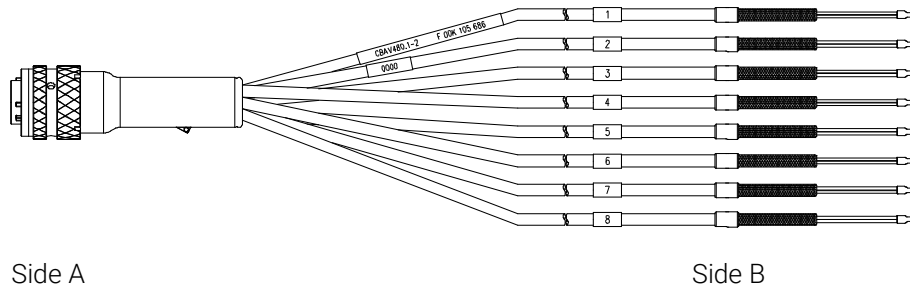

**Fig. 8-21** CBAV480.1 Cable

The CBAV480.1 cable consists of eight identical cable sections, marked n=1 to n=8. Each cable section is assigned to an ES4xx measurement channel [n] and wired according to the same scheme.

The assignment of the cable connections of a cable section to the signals of a measurement channel [n] is shown in the table.

Signal	Meaning	Color
CH[n] In+	Measurement channel [n], input (+)	white
CH[n] In-	Measurement channel [n], input (-)	brown

#### Notes about the Application

Temperature rated for: -40 °C to +125 °C

Product	Length	Order Number
CBAV480.1-2	2 m	F 00K 105 686

## 8.4 Protective Caps

The connections "IN" and "OUT" of the ES410.1 can be protected with different protective caps according to the operating conditions.

### 8.4.1 Protective Caps supplied

The "IN" and "OUT" ports of the ES4xx are covered with simple dust and transport caps on delivery. These caps are only suitable for the limited temperature range of -40 °C to +70 °C



#### NOTE

The protective caps supplied are in no way a replacement for or viable alternative to the caps CAP\_LEMO\_1 and CAP\_LEMO\_1B\_LC.

### 8.4.2 Cap CAP\_LEMO\_1B

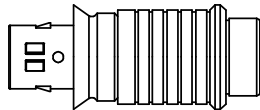

Fig. 8-22 Cap CAP\_LEMO\_1B

The cap CAP\_LEMO\_1B protects the connection "IN" or "OUT" against dirt according to IP67.

Product	Order number
CAP_LEMO_1B	F 00K 105 298

### 8.4.3 Cap CAP\_LEMO\_1B\_LC

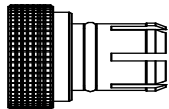

Fig. 8-23 Cap CAP\_LEMO\_1B\_LC

The cap CAP\_LEMO\_1B\_LC protects the connection "IN" or "OUT" in an inexpensive way against dirt.

Product	Order number
CAP_LEMO_1B_LC	F 00K 105 683

### 8.4.4 Cap CAP\_SOURIAU\_8STA

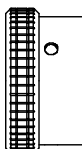

Fig. 8-24 Cap CAP\_SOURIAU\_8STA

The cap CAP\_SOURIAU\_8STA protects the "Sensor" port against water and dirt.

Product	Order number
CAP_SOURIAU_8STA	F 00K 105 303

## 8.5 Angle Brackets

### 8.5.1 Angle Bracket Left

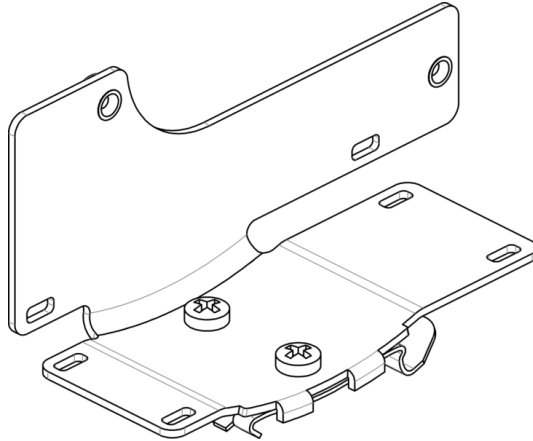
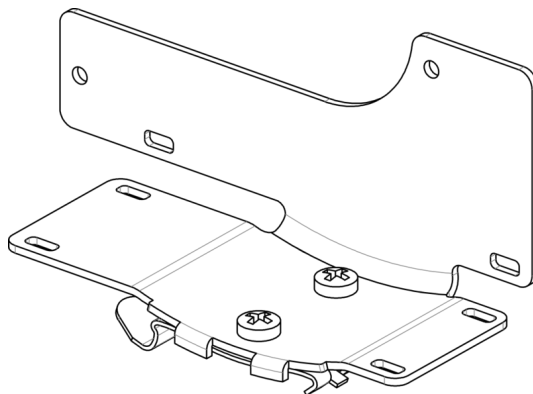

**Fig. 8-25** Angle Bracket Left

Angle Bracket for mounting ES4xx modules to a DIN rail 35 x 7.5 (EN 60715 TH35). Stainless steel V2A. For mounting on left side of an ES4xx module.

Product	Order number
Angle bracket left	F 00K 107 175

### 8.5.2 Angle Bracket Right



**Fig. 8-26** Angle Bracket Right

Angle Bracket for mounting ES4xx modules to a DIN rail 35 x 7.5 (EN 60715 TH35). Stainless steel V2A. For mounting on right side of an ES4xx module.

Product	Order number
Angle bracket right	F 00K 107 176

## 9 Ordering Information

---

### 9.1 ES410.1

---

Order name	Short name	Order number
ES410.1 A/D Module (8-CH)	ES410.1	F 00K 105 691

#### Scope of supply

- ES410.1 Micro A/D Measurement Module
- CDROM ES4xx\_DRV\_SW\_CD (drivers for ES4xx and documentation)
- List "Content of this Package"
- ES4xx Safety Advice
- China-RoHS-leaflet\_Compact\_green\_cn
- Calibration-Certification

### 9.2 Accessories

---

#### 9.2.1 Cables



#### NOTE

If you require customized cables, please contact your ETAS contact partner or [sales.de@etas.com](mailto:sales.de@etas.com).

#### Cables for the connectors "IN" and "OUT"

##### Ethernet cable

Order name	Short name	Order number
Ethernet Chain Connection Cable, Lemo 1B FGF - Lemo 1B FGL (8mc-8fc), 3 m	CBE400.2-3	F 00K 104 920
Ethernet Chain Connection Cable, Highly Flexible, Lemo 1B FGF - Lemo 1B FGL (8mc-8fc), 0.5 m	CBE401.1-0m5	F 00K 106 128
Ethernet Chain Connection Cable, Lemo 1B FGA - Lemo 1B FGL (8mc-8fc), 0m45	CBE430.1-0m45	F 00K 104 923
Ethernet Chain Connection Cable, Highly Flexible, Lemo 1B FGA - Lemo 1B FGL (8mc-8fc, 0m14)	CBE431.1-0m14	F 00K 105 676
Ethernet Chain Connection Cable, Highly Flexible, Lemo 1B FGA - Lemo 1B FGL (8mc-8fc, 0m30)	CBE431.1-0m3	F 00K 105 685
Ethernet Extension Cable, Lemo 1B PHL - Lemo 1B FGL (8mc-8fc), 3 m	CBEX400.1-3	F 00K 105 294

### Combined Ethernet and power supply cable

Order name	Short name	Order number
Ethernet PC Connection and Power Supply Cable, Lemo 1B FGL - RJ45 - Banana (8fc-8mc-2mc), 3 m	CBEP410.1-3	F 00K 104 927
Ethernet PC Connection and Power Supply Cable, Lemo 1B FGL - RJ45 - Safety Banana (8fc-8mc-2mc), 3 m	CBEP4105.1-3	F 00K 110 026
Ethernet PC Connection and Power Supply Cable, Power Feeder close to PC, Lemo 1B FGL - RJ45 - Banana (8fc-8mc-2mc), 5 m	CBEP415.1-5	F 00K 105 680
Ethernet PC Connection and Power Supply Cable, Power Feeder close to PC, Lemo 1B FGL - RJ45 - Safety Banana (8fc-8mc-2mc), 5 m	CBEP4155.1-5	F 00K 110 027
Ethernet Connection and Power Supply Cable, Lemo 1B FGF - Lemo 1B FGL - Banana (8mc-8fc-2mc), 3 m	CBEP420.1-3	F 00K 105 292
Ethernet Connection and Power Supply Cable, Lemo 1B FGF - Lemo 1B FGL - Safety Banana (8mc-8fc-2mc), 3 m	CBEP4205.1-3	F 00K 110 041
Ethernet Connection and Power Supply Cable, Power Feeder close to Interface Module, Lemo 1B FGF - Lemo 1B FGL - Banana (8mc-8fc-2mc), 3 m	CBEP425.1-3	F 00K 105 972
Ethernet Connection and Power Supply Cable, Power Feeder close to Interface Module, Lemo 1B FGF - Lemo 1B FGL - Safety Banana (8mc-8fc-2mc), 3 m	CBEP4255.1-3	F 00K 110 029
Ethernet Chain Connection and Power Supply Cable, Lemo 1B FGL - Lemo 1B FGA - Banana (8fc-8mc-2mc), 0m5	CBEP430.1-0m5	F 00K 104 928
Ethernet Chain Connection and Power Supply Cable, Lemo 1B FGL - Lemo 1B FGA - Safety Banana (8fc-8mc-2mc), 0m5	CBEP4305.1-0m5	F 00K 110 030

### Ethernet Bridge

Order name	Short name	Order number
Bridge to connect two assembled ES4xx Modules	ES4xx_BRIDGE	F 00K 105 684

### Cables for the connector "Sensor"

Order name	Short name	Order number
Analog Input Splitter Cable, Souriau 8ST12-35 - 8 x BNC (22mc-2fc), 0m2	CBAV401.1-0m2	F 00K 105 687
Analog Input Splitter Cable, Souriau 8ST12-35 - 8 x BNC (22mc-2mc), 2 m	CBAV403.1-2	F 00K 105 688
Analog Input Splitter Cable, Souriau 8ST12-35 - 8 x open wires (22mc- 2c), 2 m	CBAV480.1-2	F 00K 105 686

### 9.2.2 Protective Caps

Order name	Short name	Order number
Cap to protect open Lemo 1B sockets against dirt	CAP_Lemo_1B	F 00K 105 298
Cap to protect open Lemo 1B sockets against dirt, cost effective	CAP_Lemo_1B_LC	F 00K 105 683
Cap to protect unused Souriau sockets against dirt and water	CAP_SOURIAU_8STA	F 00K 105 303

### 9.2.3 Angle Brackets

Order name	Short name	Order number
ES4xx Angle Bracket left	ES4xx_AB_L	F 00K 107 175
ES4xx Angle Bracket right	ES4xx_AB_R	F 00K 107 176

### 9.2.4 Calibration

 **NOTE**  
 ETAS recommends a calibration interval of 12 months.

#### 9.2.4.1 Factory calibration

##### Factory calibration service

- Verification of measurement accuracy
- Issue a standard-compliant calibration certificate

Order name	Short name	Order number
Calibration service for ES410	C_ES410	F-00K-112-730

### Adjustment service

- Verification of measurement accuracy
- Adjustment of the measuring accuracy to the smallest possible deviation
- Issue standard-compliant calibration certificates for "pre-adjustment" and "post-adjustment"

Order name	Short name	Order number
Adjustment service for ES410	A_ES410	F-00K-105-928

#### 9.2.4.2 Accredited calibration

### Accredited calibration service according to ISO/IEC 17025

- Verification of measurement accuracy by accredited calibration laboratory<sup>1</sup>
- Issue an internationally recognized ISO/IEC 17025 calibration certificate.<sup>2</sup>

Order name	Short name	Order number
DAkkS calibration service for ES410	DAkkS_C_ES410	F-00K-112-775

### Accredited adjustment service according to ISO/IEC 17025

- Verification of measurement accuracy by accredited calibration laboratory<sup>1</sup>
- Adjustment of the measuring accuracy to the smallest possible deviation
- Issue of internationally recognized, ISO/IEC 17025 compliant calibration certificates for "pre-adjustment" and "post-adjustment"<sup>2</sup>

Order name	Short name	Order number
DAkkS adjustment service for ES410	DAkkS_A_ES410	F-00K-111-774

---

1. Accreditation by Deutsche Akkreditierungsstelle (DAkkS)  
2. Supervision of the calibration certificate by DAkkS



## 10 Contact Information

---

### ETAS Headquarters

ETAS GmbH

Borsigstraße 24  
70469 Stuttgart  
Germany

Phone: +49 711 3423-0  
Fax: +49 711 3423-2106  
Internet: [www.etas.com](http://www.etas.com)

### ETAS Subsidiaries and Technical Support

For details of your local sales office as well as your local technical support team and product hotlines, take a look at the ETAS website:

ETAS subsidiaries            Internet: [www.etas.com/en/contact.php](http://www.etas.com/en/contact.php)  
ETAS technical support    Internet: [www.etas.com/en/hotlines.php](http://www.etas.com/en/hotlines.php)

## Figures

Fig. 3-1	Central and Decentral Sensor Cabling	13
Fig. 3-2	Front	15
Fig. 4-1	ES410.1 Housing	18
Fig. 4-2	Block Diagram	19
Fig. 4-3	Signal Processing and Filters of a Measurement Channel	20
Fig. 4-4	Filter with and without Compensation of the Group Delay	21
Fig. 4-5	Maximum Input and Common-Mode Voltages	22
Fig. 4-6	Message Format "XCP on UDP" (Schematic)	23
Fig. 4-7	Time-Multiplex Data Transfer Between an ES400 Module Chain and a PC	26
Fig. 4-8	Transfer Scheme for Example 1 (Simplified, Not True to Scale)	26
Fig. 4-9	Time-Multiplex Data Transfer Between an ES400 Module Chain and a PC	27
Fig. 4-10	Transfer Scheme for Example 2 (Simplified, Not True to Scale)	27
Fig. 5-1	Position of the Pressure Balance Element	33
Fig. 5-2	How to Attach ES400 Modules	33
Fig. 5-3	Accessing the Integrated Assembly Elements	34
Fig. 5-4	Unscrewed Integrated Assembly Elements	34
Fig. 5-5	Connecting Several ES400 Modules Using the Integrated Assembly Elements	35
Fig. 5-6	Connected ES400 Modules	36
Fig. 5-7	Attaching a Module to Other Components with the Integrated Assembly Elements	37
Fig. 5-8	Connecting to Other Modules	39
Fig. 5-9	Fastening to an ES4xx Angle Bracket (left) using the Integrated Assembly Elements	39
Fig. 5-10	Attaching to Other Components Using Additional Screws	41
Fig. 5-11	Fastening on DIN Rails with Additional Screws	43
Fig. 5-12	Openings for Cable Fasteners in ES400 Modules	45
Fig. 5-13	Drilling Template	47
Fig. 5-14	ES410.1 with additional ETAS Modules for MC Applications	48
Fig. 5-15	ES410.1 with ES910.3 and additional ETAS Modules for Rapid Prototyping Applications	49
Fig. 5-16	ES400 Modules with additional ETAS Modules (Measurement and Calibration)	50
Fig. 5-17	ES400 Modules with additional ETAS Modules and Drive Recorder (Measurement and Calibration)	51
Fig. 5-18	ES400 Modules with ES910.3 (Rapid Prototyping)	52
Fig. 5-19	ES400 Modules with ES910.3 and Drive Recorder (Rapid Prototyping)	53
Fig. 5-20	ES400 Modules with ETAS RTPRO-PC (Rapid Prototyping)	54

Fig. 5-21	ES410.1 with ES4xx_BRIDGE .....	55
Fig. 7-1	WEEE symbol .....	69
Fig. 7-2	“IN” Connector .....	75
Fig. 7-3	“OUT” Connector .....	76
Fig. 7-4	“Sensor” Connector .....	77
Fig. 8-1	CBEP410.1 Cable .....	80
Fig. 8-2	CBEP4105.1 Cable .....	80
Fig. 8-3	CBEP415.1 Cable .....	81
Fig. 8-4	CBEP4155.1 Cable .....	81
Fig. 8-5	CBEP420.1 Cable .....	82
Fig. 8-6	CBEP4205.1 Cable .....	82
Fig. 8-7	CBEP425.1 Cable .....	83
Fig. 8-8	CBEP4255.1 Cable .....	83
Fig. 8-9	CBEP430.1 Cable .....	84
Fig. 8-10	CBEP4305.1 Cable .....	84
Fig. 8-11	CBE400.2 Cable .....	85
Fig. 8-12	CBE401.1 Cable .....	85
Fig. 8-13	CBE430.1 Cable .....	86
Fig. 8-14	CBE431.1 Cable .....	86
Fig. 8-15	CBEX400.1 Cable .....	86
Fig. 8-16	ES4xx Bridge .....	87
Fig. 8-17	CBAV401.1 Cable .....	88
Fig. 8-18	Connection „Sensor“ (one Cable Section) .....	88
Fig. 8-19	CBAV403.1 Cable .....	89
Fig. 8-20	Connection „Sensor“ (one Cable Section) .....	89
Fig. 8-21	CBAV480.1 Cable .....	90
Fig. 8-22	Cap CAP_LEMO_1B .....	91
Fig. 8-23	Cap CAP_LEMO_1B_LC .....	91
Fig. 8-24	Cap CAP_SOURIAU_8STA .....	91
Fig. 8-25	Angle Bracket Left .....	92
Fig. 8-26	Angle Bracket Right .....	92

# Index

---

## Symbols

"IN" connector	75
"OUT" connector	76
"Sensor" connector	77
"Sensor" port	16

## A

A/D converter	20, 72
Accessories	78, 93
Accident prevention	8
Accredited calibration	96
Aliasing effects	21
Ambient temperature	66
Anti-aliasing filter	20
Applications	31, 48, 55
Assembly elements, integrated	33

## B

Binary counter	24
Block diagram	19

## C

### Cable

CBAV401.1	88
CBAV403.1	89
CBAV480.1	90
CBE400.2	85
CBE401.1	85
CBE430.1	86
CBE431.1	86
CBEP410.1	80
CBEP4105.1	80
CBEP415.1	81
CBEP4155.1	81
CBEP420.1	82
CBEP4205.1	82
CBEP425.1	83
CBEP4255.1	83
CBEP430.1	84
CBEP4305.1	84
CBEX400.1	86

Cable fasteners	34, 46
-----------------	--------

Cables	78
--------	----

Calibration	31
-------------	----

Cap CAP_Lemo_1B	91
-----------------	----

Cap CAP_Lemo_1B_LC	91
--------------------	----

Cap CAP_SOURIAU_8STA	91
----------------------	----

CE conformity	68
---------------	----

Communication protocols	23
-------------------------	----

Configuration	31
---------------	----

## D

Daisy chain ports	16, 55
-------------------	--------

Daisy chain topology	14
----------------------	----

DAkS	96
------	----

### Data

electrical	71
------------	----

mechanical	68
------------	----

Data transfer	23
---------------	----

Decentral wiring concept	14
--------------------------	----

Deutsche Akkreditierungsstelle	96
--------------------------------	----

Device calibration	95
--------------------	----

Documentation	8
---------------	---

Drilling template	47
-------------------	----

Duplex operation	23
------------------	----

## E

Electrical data	71
-----------------	----

Electrical safety	9
-------------------	---

Ethernet frame	24
----------------	----

## F

Factory calibration	95
---------------------	----

Features defined by IP6	33
-------------------------	----

Filter	72, 74
--------	--------

Filters	20
---------	----

Firmware update	31
-----------------	----

Functional state	17
------------------	----

## G

Generator	24
-----------	----

Getting Started	32, 55
-----------------	--------

Group delay	20
-------------	----

## H

### Hardware

system requirements	70
---------------------	----

Host interface	71
----------------	----

Housing	15
---------	----

HSP	31
-----	----

## I

Impedance	73
-----------	----

INCA sampling rate	21
--------------------	----

Input filter	72, 74
--------------	--------

Input impedance	73
-----------------	----

### Input voltage

maximum	72
---------	----

Input voltage ranges	72
----------------------	----

Input voltage resolution	73
--------------------------	----

## K

KCC conformity	68
----------------	----

## L

LED	16
-----	----

Liquids	33
---------	----

Localizing the module	14
-----------------------	----

## M

MAC address	24
-------------	----

Master function	23
-----------------	----

Measurement accuracy, adherence	71
---------------------------------	----

Measurement channels	19
----------------------	----

Measurement error	73
-------------------	----

Mechanical data	68	Tool integration	31
Module ID	23	Troubleshooting	57
Multiple feeding	28	<b>U</b>	
<b>N</b>		UKCA conformity	68
Norms	66	Use, intended	8
<b>O</b>		<b>V</b>	
Openings for cable fasteners	34	Voltage drift	73
Operational state	16	<b>W</b>	
Ordering	93	Waste Electrical and Electronic Equipment	
Ordering information	93	- WEEE	69
Overvoltage protection	20	Water	33
<b>P</b>		WEEE return system	69
Passenger cell	15	Wiring	55
PC Card	57	Wiring concepts	13
PC network adapter	70	Wiring, Daisy Chain	55
Ports	15	Wiring, sensors	55
Potential differences	28	<b>X</b>	
Power supply	28, 72	XCP	14, 31
Power supply management	28	XCP protocol	23
Product		<b>Y</b>	
Exclusion of liability	8	Y boost cable	28
Product return	69		
Protective caps	91		
Protocol, UDP/IP	23		
Protocol, XCP	23		
<b>Q</b>			
Qualification, required	8		
<b>R</b>			
REACH regulation (EU)	69		
Recycling	69		
Resolution	72, 73, 74		
Reverse feeding	28		
RoHS conformity			
China	68		
European Union	68		
<b>S</b>			
Safety at work	8, 9		
Safety notices			
basic	8		
Safety precautions	8		
Sampling rate	72, 74		
Sensor cables	88		
Service state	17		
Signal Processing	74		
Signal processing	20		
Software			
system requirements	70		
Standards	66		
Supply voltage	72		
Synchronization of the timebases	25		
Synchronization, clock generator	25		
<b>T</b>			
Time slice procedure	24		
Time stamp	23		