

ES1337.2 Wheel Speed Sensor Simulation Board User's Guide



Copyright

The data in this document may not be altered or amended without special notification from ETAS GmbH. ETAS GmbH undertakes no further obligation in relation to this document. The software described in it can only be used if the customer is in possession of a general license agreement or single license. Using and copying is only allowed in concurrence with the specifications stipulated in the contract.

Under no circumstances may any part of this document be copied, reproduced, transmitted, stored in a retrieval system or translated into another language without the express written permission of ETAS GmbH.

© **Copyright 2018** ETAS GmbH, Stuttgart

The names and designations used in this document are trademarks or brands belonging to the respective owners.

V1.0.0 R04 EN - 11.2023

Contents

1	Introduction	5
1.1	Areas of Use and Features	5
1.2	Block Diagram	8
1.3	Taking the Product Back and Recycling	9
2	Hardware Features	11
2.1	Wheel Speed Sensors	11
2.1.1	Type "DF6"	12
2.1.2	Type "DF10"	13
2.1.3	Type "DF10-RotDir"	14
2.1.4	Type "DF11i"	15
2.1.5	Type "VDA"	17
2.2	Analog Outputs	19
2.2.1	Reference Voltages	19
2.2.2	Type of Output Signal	19
2.2.3	Disabling the Output	19
2.3	Synchronization Signal	19
3	Pin Assignment and Display Elements	21
3.1	Pin Assignment	21
3.1.1	"OUTPUT 0-5" Signal Outputs	21

3.1.2	"SYNC" Port	22
3.2	LEDs	23
4	Technical Data	25
5	ETAS Contact Addresses	27
	Index	29

1

Introduction

This User's Guide describes the ES1337.2 Signal Generator Board.

This section contains information on the basic functions and the area of use of the ES1337.2 Signal Generator Board.



CAUTION!

Some components of the ES1337.2 Signal Generator Board may be damaged or even destroyed by static discharge. Leave the board in its transport package until you want to install it. The ES1337.2 Signal Generator Board should only be taken from its package, configured and installed at a working place that is protected against static discharge.



WARNING!

The components, connectors and conductors of the ES1337.2 Signal Generator Board may carry dangerous voltages. These voltages may even exist if the ES1337.2 is not installed in the ES4100 or the ES4105 and the ES4100 or the ES4105 is powered off. Make sure the ES1337.2 is protected against contact during operation. Disconnect all connectors to the ES1337.2 before removing the board.

1.1 Areas of Use and Features

The correct determination of the wheel speed by wheel speed sensors is an important prerequisite for the functioning of lots of ECUs for controlling the braking force on each individual wheel (ABS, TCS and ESP). The control prevents either the wheels blocking or the wheels spinning in an uncontrolled manner. Navigation systems also access vehicle speed when the GPS signal is weak or non-existent.

Wheel speed sensors are available in two basic designs:

- a passive design, in which the sensor element does not require an external power supply
- an active design with an external power supply of the sensor element

The designs also differ in terms of the physical effect, on which the acquisition of the wheel speeds is based, and the scope and content of the information provided by the sensor.

Features

The ES1337.2 Signal Generator Board has four independent signal generators for generating various sensor signals. The following types of sensor can be simulated:

- Passive analog sensors with a sinusoidal output signal (type "DF6")
- Active digital sensors with a current interface with two current levels (type "DF10")
- Active digital sensors with a current interface with three current levels and forwards/backwards coding (type "DF10-RotDir")
- Active digital sensors with a current interface with two current levels and additional information (type "DF11i")
- Active digital sensors with a current interface with three current levels and additional information (type "VDA")

In addition, there are two other galvanically isolated analog voltage outputs.

The ES1337.2 Signal Generator Board has the following features:

- Four identical, galvanically isolated signal generators for generating speed signals
- Outputs: ± 10 V and 0...40 mA with 10-bit resolution
- Two identical, galvanically isolated analog outputs:
 - ± 10 V with 10-bit resolution
 - Configurable reference voltages (internal/external)
- Every channel is protected against overvoltages to ± 60 V
- All outputs with a cut-off relay
- Stand still detection (DF11i, VDA) is supported
- Mixed sensor configurations possible

The following figure shows the front panel of the ES1337.2 Signal Generator Board with

- the LEDs (see "LEDs" on page 23)
- the port for the signal outputs, signal grounds and external reference voltages (see "'OUTPUT 0-5" Signal Outputs" on page 21).
- the "SYNC" port (see "'SYNC" Port" on page 22) for outputting a synchronization signal ("tooth 0"), for example to an oscilloscope.

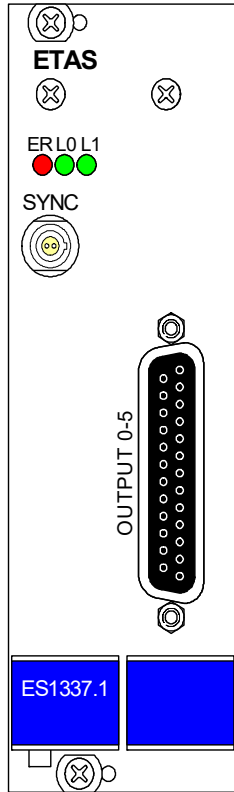

Fig. 1-1 Front View of the ES1337.2 Signal Generator Board

1.2 Block Diagram

Fig. 1-2 shows a block diagram with all important function units of the ES1337.2 Signal Generator Board.

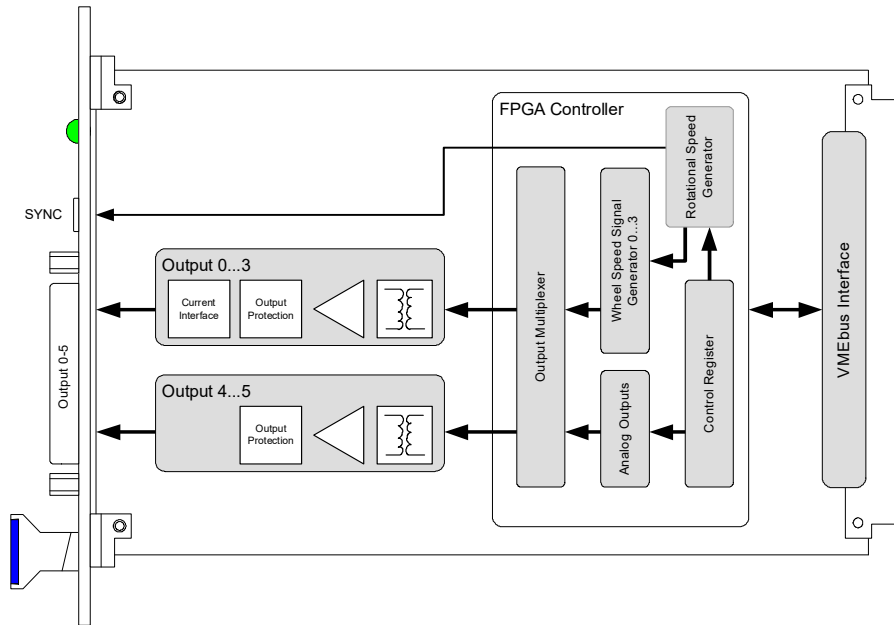

Fig. 1-2 Block Diagram of the ES1337.2 Signal Generator Board

1.3 Taking the Product Back and Recycling

The European Union has passed a directive called Waste Electrical and Electronic Equipment, or WEEE for short, to ensure that systems are setup throughout the EU for the collection, treating and recycling of electronic waste.

This ensures that the devices are recycled in a resource-saving way representing no danger to health or the environment.



Fig. 1-3 WEEE Symbol

The WEEE symbol on the product or its packaging shows that the product must not be disposed of as residual garbage.

The user is obliged to collect the old devices separately and return them to the WEEE take-back system for recycling.

The WEEE directive concerns all ETAS devices but not external cables or batteries.

For more information on the ETAS GmbH Recycling Program, contact the ETAS sales and service locations (see "ETAS Contact Addresses" on page 27).

2 Hardware Features

This section contains information on the features of the ES1337.2 Signal Generator Board.

2.1 Wheel Speed Sensors

This section contains a description of the types of wheel speed sensor that can be simulated with the ES1337.2 Signal Generator Board.

- "Type "DF6"" on page 12
- "Type "DF10"" on page 13
- "Type "DF10-RotDir"" on page 14
- "Type "DF11i"" on page 15
- "Type "VDA"" on page 17

A basic distinction is made between two processes for recording wheel speeds: passive and active sensors.

With passive sensors, there is usually an encoder wheel made of ferromagnetic material which closely runs past a magnet surrounded by a coil. This results in a constant change of the magnetic flux density which induces a voltage in the coil.

Active sensors often use an encoder wheel made of alternately opposing magnetized segments – the signal is generated in an active circuit by measuring the magnetoresistance or the Hall effect in a sensor.

2.1.1 Type "DF6"

A sensor of type "DF6" is a passive sensor consisting of a magnet wrapped in a coil in the vicinity of an encoder gear wheel.

The coil and the magnet are mounted on the vehicle or the axle – the movement of the teeth of the encoder wheel along one pole of the permanent magnet generates an AC signal in the coil which is routed to the corresponding ECU.

The resulting sensor signal approximates the form of a sinusoidal signal (see Fig. 2-1).

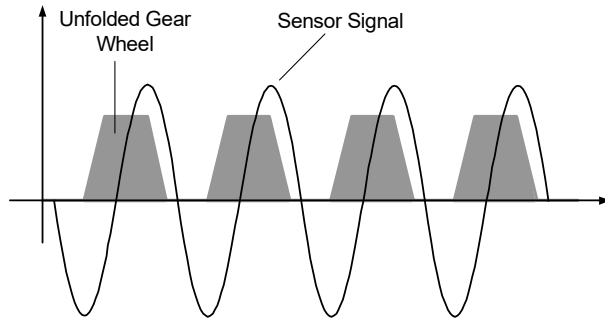

Fig. 2-1 Signal of a Passive "DF6" Sensor

Every tooth generates a period of the sinusoidal oscillations – the signal amplitude depends on the size of the gap between the individual teeth (the air gap) and the speed. The greater the speed and the smaller the gap, the greater the induced voltage.

A great disadvantage with this sensor type is the low signal amplitude with low speeds.

2.1.2 Type “DF10”

A sensor of type “DF10” is an active sensor in which the signal amplitude is independent of the speed.

The magnetoresistance is made use of here which leads to the electrical resistance of certain materials changing when they are brought into contact with a magnetic field. Oscillations of the magnetic flux density correspondingly lead to fluctuations in the resistance.

In addition to the actual sensor element, magnetoresistance sensors consists of a permanent magnet and a two-wire connection for the power supply (battery voltage) and the sensor signal.

This sensor is then positioned on the gear wheel so that there are changes in the resistance due to changes in the flux density between the tooth and the gap. The post-connected evaluation unit then returns defined currents of 7 mA (gap) or 14 mA (tooth).

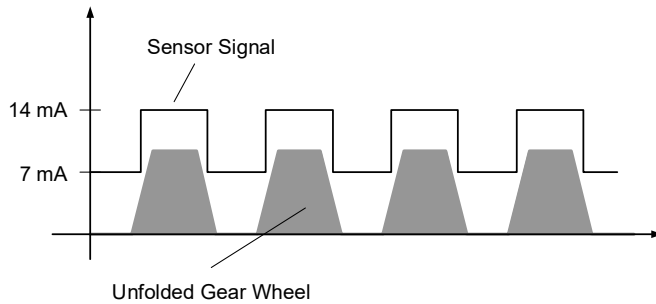

Fig. 2-2 Output Signal of a “DF10” Sensor

The advantage of this principle is that the output signal is not speed-dependent and thus speeds to value 0 can be acquired.

2.1.3 Type "DF10-RotDir"

The sensor of type "DF10-RotDir" differs from "DF10" in that a third current level is output with reverse movement:

When the vehicle is not moving (speed level $< v_{min}$), the current $I_{idle} = 7 \text{ mA}$ is output. The currents in forward movement and reverse movement are shown in Fig. 2-3.

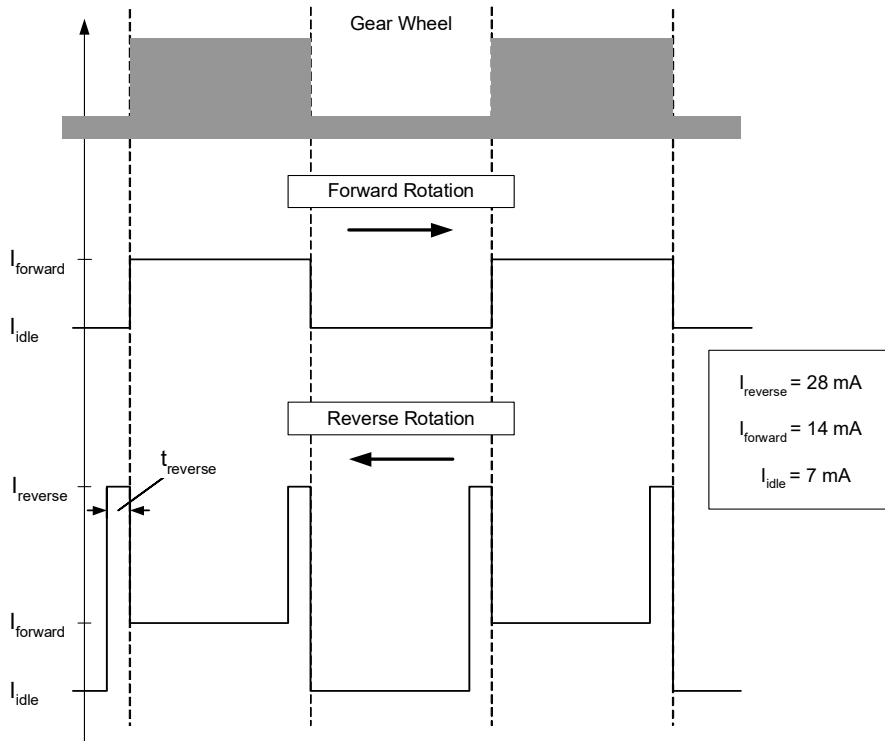

Fig. 2-3 Output Signals of a "DF10-RotDir" Sensor

A reverse movement is shown when the sensor outputs a current $I_{reverse} = 28 \text{ mA}$ for a short time $t_{reverse}$.

2.1.4 Type “DF11i”

While sensors of types “DF6” and “DF10” only provide the relevant ECU with information on the wheel speed, sensors of the type “DF11i” (and of type “VDA”) output pulse-width modulated signals in which additional information such as direction of rotation and magnetic field strength are coded. These sensors are active sensors whose functioning is based on the Hall effect.

In most cases, the encoder wheel consists of plastic elements (mounted on a non-magnetic metallic carrier) of opposing magnetization which results in a sign change of the Hall voltage on rotation.

It is, however, also possible for the encoder wheel to be made of a ferromagnetic material – in this case, the Hall element is positioned on a permanent magnet. The change between tooth and gap of the encoder wheel leads to a change of the magnetic flux density and thus to fluctuations in the Hall voltage.

The signals ultimately provided by the sensor consist of current pulses of 14 mA (low = 7 mA) whose frequency is proportional to the speed and whose rising edges have a precise temporal relationship to the change of the segments.

The pulse width is determined by the direction of rotation and the field strength: It consists of multiples of a well-defined time interval.

When the encoder wheel is paused or there is no change to the sensor signal for another reason, a standstill pulse with approx. 1.5 Hz repetition rate is output.

Fig. 2-4 on page 16 shows the various output signals of a “DF11i” sensor:

- A high-level pulse is output when there is a segment change at the encoder wheel. This pulse is preceded by a short low-phase T_0 typically 45 μ s long – this phase is referred to as the pre-bit phase.
- A large gap results in a low magnetic field strength. This is indicated by a high pulse of width T_0 (air gap limit¹). This signal is output for both directions of rotation.
- Normal field strengths are shown by pulse widths of 2 T_0 (reverse direction of rotation) or 4 T_0 (forward direction of rotation).
- The field strength range above the air gap limit is referred to as the mounting position error range. In this range, a pulse of length 8 T_0 (reverse direction of rotation) or 16 T_0 (forward direction of rotation) is output.

¹. The air gap limit specifies whether the magnetic field strength change is below a value necessary for perfect functioning.

- If there is no field available or if the wheel stands still for more than 737 ms, a high pulse of width $32 T_0$ is output every 737 ms.

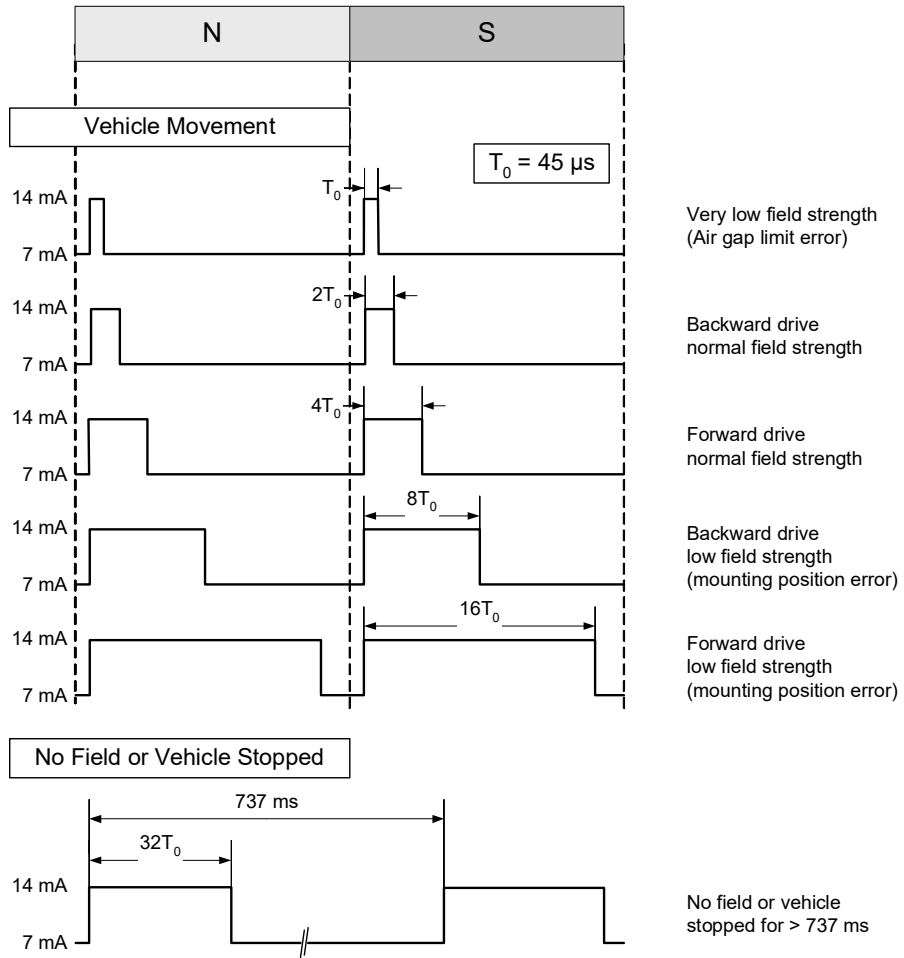

Fig. 2-4 Output Signals of a "DF111" Sensor

2.1.5 Type “VDA”

“VDA” sensors are also active sensors and, like the “DF11i” sensors, are based on the Hall effect.

The following figure shows the output signal of this sensor.

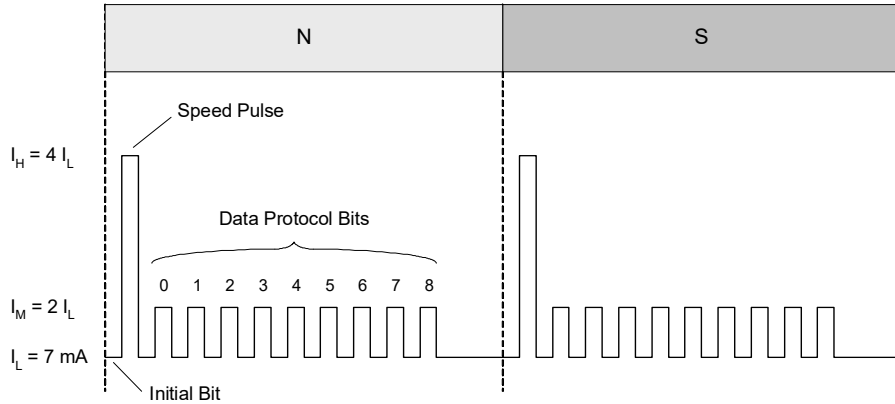

Fig. 2-5 Speed Pulse and Data Bits

The speed pulse is output at every “edge” of the encoder wheel – the current I_H of this pulse is four times the low level $I_L = 7 \text{ mA}$.

An initial bit that sets the current level to I_L precedes this pulse. A further nine bits follow the speed pulse with a current level of $I_M = 2 I_L$.

The meaning of these bits is described in the following table.

Bit Number	Meaning	Coding
0	Error bit air gap limit	0 = correct 1 = air gap limit
1	Can be assigned freely	
2	Can be assigned freely	
3	Validity of direction of rotation	0 = invalid 1 = valid
4	Direction of rotation	0 = positive 1 = negative
5	Can be assigned freely	
6	Can be assigned freely	
7	Can be assigned freely	
8	Parity bit	Is set to 0 or 1 to retain even parity (incl. the parity bit itself).

Tab. 2-1 Meaning of the Nine Protocol Bits

2.2 Analog Outputs

Each of the two analog voltage outputs of the ES1337.2 Signal Generator Board can be configured so that

- the internal reference voltage or one applied from outside is used
- an analog signal or a digital signal derived from the output voltage is output
- an output configured as digital is used as an open collector output or as an open collector output with pull-up functionality
- the output is completely powered off

2.2.1 Reference Voltages

The internal reference voltage (= 10 V) or a voltage applied to the external reference voltage input of the channel between -10.0 V and 10.0 V (see "“OUTPUT 0-5” Signal Outputs" on page 21) are available.

The actual output voltage of the relevant channel is the product of the reference voltage and the control signal (with an analog configuration).

The reference voltage is selected in the "Globals" tab of the ES1337-Wheelsnrsim-DA Device ("Analog Reference Output #4, #5" option) in LABCAR-RTC.

2.2.2 Type of Output Signal

The digital signal is derived from the analog signal – the comparator threshold corresponds to 1 V when using the internal reference or $0.1 \times V_{\text{ext}}$ when using the external reference.

Selection takes place in the "Globals" tab of the ES1337-Wheelsnrsim-DA Device ("Configuration Output #4, #5" option) in LABCAR-RTC.

2.2.3 Disabling the Output

An analog channel is disabled in the "Signals" tab of the ES1337-Wheelsnrsim-DA Device ("Enable_4" and "Enable_5" option) in LABCAR-RTC. The channel output is high-impedance when disabled.

2.3 Synchronization Signal

To synchronize with external devices (e.g. an oscilloscope), one of the four wheel speed sensors can output a "tooth 0-pulse" as a TTL signal at the "SNYC" port.

The sensor this signal comes from is selected in LABCAR-RTC in the "Globals" tab of the ES1337-Wheelsnrsim Subsystem ("SYNC Port" option).

3 Pin Assignment and Display Elements

This chapter describes the ports and LEDs of the ES1337.2 Signal Generator Board. It consists of the following sections:

- "Pin Assignment" on page 21
This section contains a description of all the ports on the front panel.
- "LEDs" on page 23
This section explains the meaning of the LED displays on the front panel.

3.1 Pin Assignment

This section describes the pin assignment of the connectors for the output signals and the synchronisation signals:

- "“OUTPUT 0-5” Signal Outputs" on page 21
- "“SYNC” Port" on page 22

3.1.1 “OUTPUT 0-5” Signal Outputs

The four outputs of the wheel speed generators are at this port: the two analog outputs as well as the analog grounds of all outputs and the inputs for external reference voltages of the analog outputs.

Type: DSUB 25 (female)

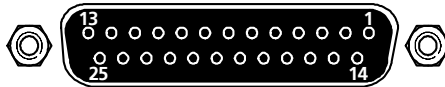

Fig. 3-1 “OUTPUT 0-5” Port

Pin	Signal	Pin	Signal
1	Channel # Output FL	14	Channel #0 Analog Ground
2	n.c.	15	Channel #0 Analog Ground
3	Channel #1 Output FR	16	Channel #1 Analog Ground
4	n.c.	17	Channel #1 Analog Ground
5	Channel #2 Output RL	18	Channel #2 Analog Ground
6	n.c.	19	Channel #2 Analog Ground
7	Channel #3 Output RR	20	Channel #3 Analog Ground
8	n.c.	21	Channel #3 Analog Ground
9	Channel #4 Output	22	Channel #4 Analog Ground
10	Channel #4 External Reference	23	Channel #4 Analog Ground
11	Channel #5 Output	24	Channel #5 Analog Ground
12	Channel #5 External Reference	25	Channel #5 Analog Ground
13	n.c.	Shielding	Protective earth

Tab. 3-1 Assignment of the “OUTPUT 0-5” Port

3.1.2 “SYNC” Port

Socket type LEMO 2-pin. Type: XBG.00.302 NLN (female)

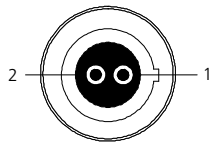

Fig. 3-2 “SYNC” Port

Pin	Assignment	Pin	Assignment
1	Synchronization signal	Shielding	Protective earth
2	VMEbus ground		

Tab. 3-2 Assignment of the “SYNC” Port

To connect this signal to a device with a BNC input, order cable “K98” (TTN: F-00K-000-656) from ETAS.

3.2 LEDs

There are several LEDs on the front panel of the ES1337.2 Signal Generator Board; what they mean is described below.



Fig. 3-3 The LED Field on the Front Panel

LED	Display	Meaning
ER	LED shows red	Error (e.g. unsuccessful attempt to access ROM memory, inconsistent or damaged ROM memory data, checksum verification resulted in an error, initialization of the RS232 interface did not work, calibration data stored in the ROM for the DA channels is incorrect or implausible)
L0	LED flashes green	1 Hz flashing frequency indicates correct functioning of the system CPU
L1	-	No function

Tab. 3-3 Meaning of the LED Displays

All LEDs are powered on briefly when the ES1337.2 is reset.

4 Technical Data

Outputs for Wheel Speed

Output Voltage	-10 V ... +10 V
Accuracy	±50 mV
Output current	0 to 40 mA
Accuracy	±0.5 mA
Output frequency	Max. 500 kHz
Electrical strength	±60 V
Galvanic isolation	Yes

Analog Voltage Outputs

External reference voltage	-10 V ... +10 V
Output voltage	-10 V ... +10 V (internal reference) -V _{ext} to +V _{ext} (external reference)
Accuracy	With internal reference: 10 Bit (±50 mV)
Output current	±30 mA
Electrical strength	±60 V
Galvanic isolation	Yes

Electrical Data

Current consumption	10 mA @ +5 V DC 160 mA @ +12 V DC 160 mA @ -12 V DC 700 mA @ +3.3 V DC
---------------------	---

Environmental Conditions

Operating temperature	+5 °C to +35 °C (+41 °F to +95 °F)
Relative humidity	0 to 95% (non-condensing)

5 **ETAS Contact Addresses**

ETAS HQ

ETAS GmbH

Borsigstraße 24

70469 Stuttgart

Germany

Phone: +49 711 3423-0

Fax: +49 711 3423-2106

WWW: www.etas.com

ETAS Subsidiaries and Technical Support

For details of your local sales office as well as your local technical support team and product hotlines, take a look at the ETAS website:

ETAS subsidiaries WWW: www.etas.com/en/contact.php

ETAS technical support WWW: www.etas.com/en/hotlines.php

Index

B

Block diagram 8

D

DF10 13
DF10-RotDir 14
DF11i 15
DF6 12

E

ETAS Contact Addresses 27

F

Features 5
Front view 7

L

LEDs 23

P

Pin assignment 21
 "SYNC" 22
 Analog Out 21
 signal outputs 21
Product Back 9

R

Recycling 9

T

Technical data 25

V

VDA 17

W

Waste Electrical and Electronic Equipment 9
WEEE take-back system 9
Wheel speed sensors 11