ES4031 Rack System 33U

User's Guide

Copyright

The data in this document may not be altered or amended without special notification from ETAS GmbH. ETAS GmbH undertakes no further obligation in relation to this document. The software described in it can only be used if the customer is in possession of a general license agreement or single license. Using and copying is only allowed in concurrence with the specifications stipulated in the contract.

Under no circumstances may any part of this document be copied, reproduced, transmitted, stored in a retrieval system or translated into another language without the express written permission of ETAS GmbH.

© **Copyright 1999** ETAS GmbH, Stuttgart

The names and designations used in this document are trademarks or brands belonging to the respective owners.

Dokument TS240501 R1.0.2 EN

TTN F 00K 700 263

Contents

1	Overview	5
2	ES4031 Cabinet	7
2.1	ES4070 Air Duct Module	7
3	Front Door	9
4	ECU Drawer	11
5	Master-Slave Plug Strip	13
6	Technical Data (Summary).	15

1 Overview

The ES4031 Rack System is a switching cabinet system of size 33 U. It can house an entire LabCar system consisting of a signal box, a load box and a breakout box. Additional features are a drawer for the ECU to be tested, an air duct module ES4070 and a master-slave plug strip.



This user's guide describes all parts of the ES4031 Rack System and provides all necessary information for productively using the system.

2 ES4031 Cabinet

The ES4031 Rack System can house modules up to a total height of 33 U. The dimensions of the cabinet are 700x600x1671 mm (depth x width x height). It has steerable rollers and a cable opening at the back, which can be used for power chords, etc.



To guarantee sufficient air flow, even when the front door is closed, there is a vent at the bottom and a ventilation grid at the top of the cabinet.

2.1 ES4070 Air Duct Module

The ES4070 Air Duct Module is a standard feature of the ES4031 Rack System. It does not contain any fans, but serves only to guide the airflow towards the fans of the module above it, e.g. the signal box. If required, a ventilation module with fans of its own (not included in standard configuration) can be mounted in place of the ES4070 Air Duct Module. Additionally the ES4070 Air Duct Module is fitted with a cable duct for the cables connecting the various modules of the LabCar system.

In the standard configuration the ES4070 Air Duct Module is mounted at a height of 240,45 mm (=5.4 U) its dimensions are 330x428x88,9 mm (depth x width x height).

3 Front Door

The front door of the ES4031 Rack Systems is fitted with a lock and can be detached if necessary. It is grounded with a protective lead.

To detach the front door:

- Make sure that the protective lead has been detached from the front door.

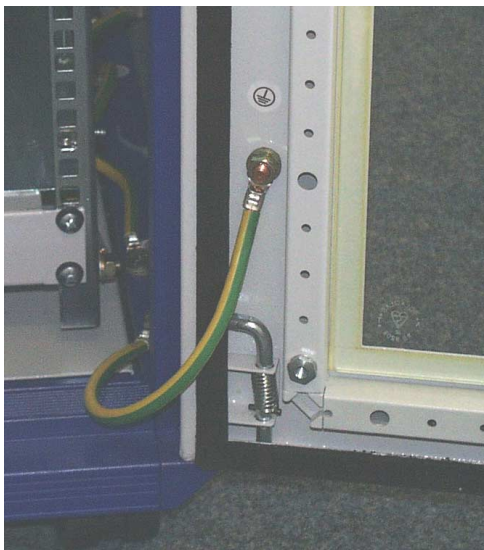

- If necessary, remove it with a size 13 spanner.

- Pull the spring-loaded bolt of the upper hinge all the way down.

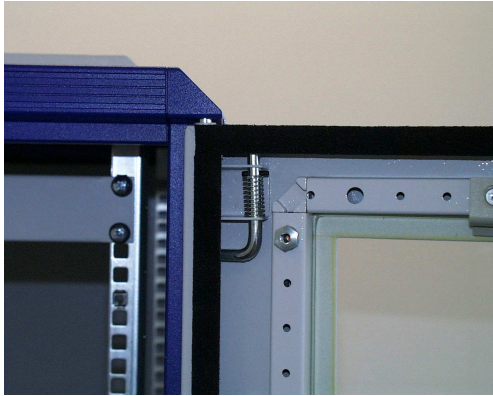

- Carefully tilt the door to the right and lift it out of the lower hinge.

note

The door weighs about 10kg. Always hold on to it with both hands, to avoid injury.

Perform the above steps in reverse order to re-attach the door.

4 ECU Drawer

In the standard configuration, the ECU drawer is located between the signal box and the breakout box. It can safely hold the ECU and its associated wiring. Normally the ECU drawer is mounted at a height of 505,8 mm (=11.4 U). Depending on your configuration, the position of the drawer within the ES4031 Rack System may vary.

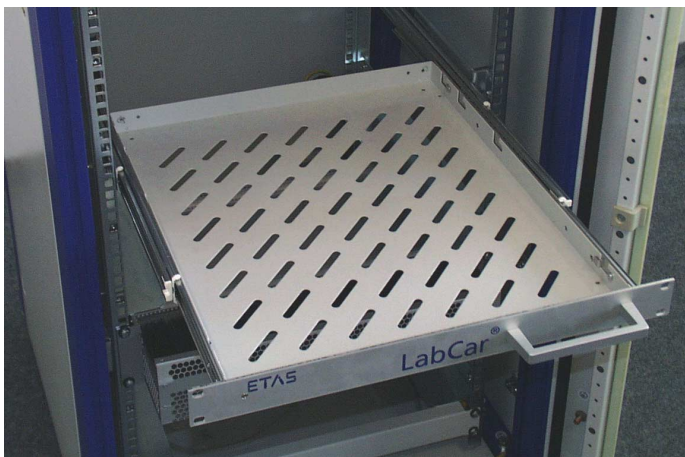

The dimensions of the ECU drawer are 460x428x44,5 mm (depth x width x height), i.e. the drawer is 1 U high. Even when a breakout box is fitted, there is an empty space above the drawer. Therefore ECUs of a height up to 130 mm can be used in the standard configuration. The drawer can be pulled out up to 380 mm. For transport the drawer can be secured with four size M6 screws on the front panel.



5 Master-Slave Plug Strip

The master-slave plug strip fitted on the back of the ES4031 Rack System serves to switch the individual modules of the LabCar system on and off, depending on the state of a previously defined module.

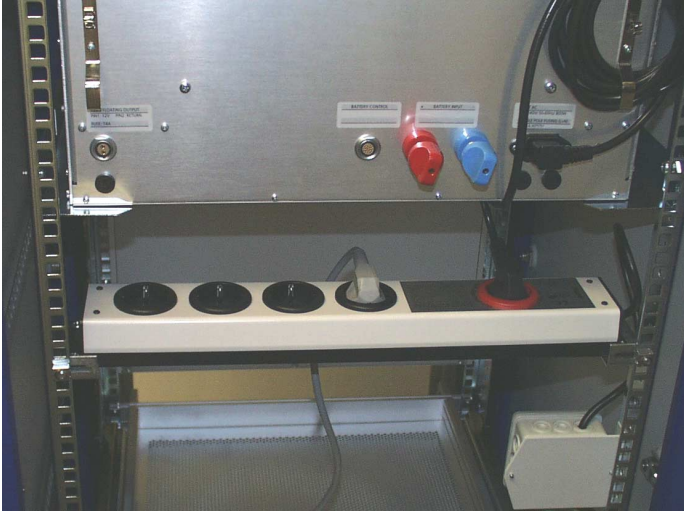

You can, for instance, make the signal box the master by plugging it into the red socket of the plug strip. When the master is switched on, this fact is detected by the plug strip. Consequently all the slave sockets are switched on via a bipolar relay. All devices connected to the slave sockets are now supplied with power. If the device connected to the master socket is switched off, all devices connected to the slave sockets are cut off from the power supply as well.

note

The master-slave plug strip has no fuse of its own. Make sure that either a separate circuit breaker is connected, or that power inputs of the modules connected to the plug strip have fuses of their own.

The following diagram shows the circuit schematics of the master-slave plug strip:

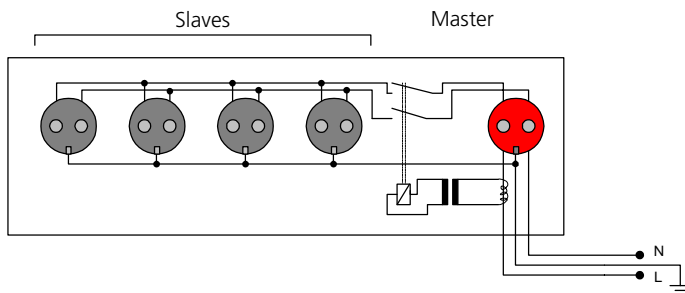

Several plug strips can be cascaded. In that case the slave sockets of the first plug strip are connected to the master sockets of the following plug strips. These then behave like slaves, i.e. they are only supplied with power, if the main master is switched on. The following diagram illustrates the principle:

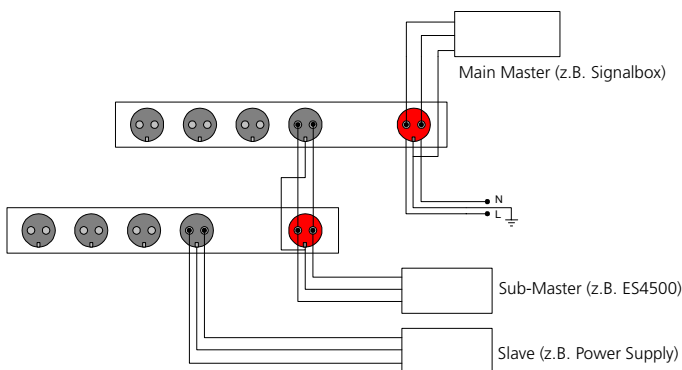

When the main master is switched on, the second plug strip is also supplied with power. If the sub-master is now switched on, all slaves of the second plug strip are also supplied with power. If the main master is switched off, all other devices are cut off from the power supply.

6 Technical Data (Summary)

Dimensions

Module	U	mm (depth x width x height)
Housing	33	700x600x1671
Fan Chassis ES4070	2	300x428x88,9
ECU drawer	1	460x428x44,45

Master-Slave Plug Strip

Outlets	1 Master, 4 Slaves
Operating Voltage	230 VAC
Max. Operating Current	16 A
Length of Supply Cable	4 m

