

PB1652LAMBDA.1-C
Signal Conditioning for Lambda Sensor Simulation
User's Guide



Copyright

The data in this document may not be altered or amended without special notification from ETAS GmbH. ETAS GmbH undertakes no further obligation in relation to this document. The software described in it can only be used if the customer is in possession of a general license agreement or single license. Using and copying is only allowed in concurrence with the specifications stipulated in the contract.

Under no circumstances may any part of this document be copied, reproduced, transmitted, stored in a retrieval system or translated into another language without the express written permission of ETAS GmbH.

© **Copyright 2013 - 2019** ETAS GmbH, Stuttgart

The names and designations used in this document are trademarks or brands belonging to the respective owners.

V1.0.0 R02 EN - 10.2019

Contents

1	Introduction	5
1.1	Features	5
1.1.1	Using with a Carrier Board.	6
1.1.2	Block Diagram	6
1.2	Basic Safety Instructions	7
1.2.1	Correct Use	7
1.2.2	Labeling of Safety Instructions	7
1.3	RoHS conformity	8
1.3.1	European Union	8
1.3.2	China	8
1.4	CE marking	8
1.5	Taking the Product Back and Recycling	8
2	Hardware	9
2.1	Assembly	9
2.2	Configuration	10
2.2.1	Jumpers for Ground Reference	10
2.2.2	Relays for the Simulation of Wide-Band Sensors of the Type "LSU5.1"	11
2.2.3	Configuration of Switching-Type Sensors	11
2.2.4	Integration of Lambda Sensor Simulation in LABCAR	12
3	Pin Assignment and LEDs	13
3.1	Front-Facing Connector of the ES1652.2 Carrier Board	13
3.2	LEDs	14
4	Technical Data	15
4.1	Fulfilled Standards and Norms	15

5 Ordering Information 16

6 ETAS Contact Addresses 17

 Index 19

1 Introduction

This User's Guide describes the PB1652LAMBDA.1-C Signal Conditioning for Lambda Sensor Simulation. This chapter contains information on the basic functions and the area of use of the PB1652LAMBDA.1-C Signal Conditioning for Lambda Sensor Simulation.

**CAUTION!**

Some components of the PB1652LAMBDA.1-C Signal Conditioning for Lambda Sensor Simulation can be damaged or destroyed by electrostatic discharge. Leave the board in the transport packaging until it is installed.

The PB1652LAMBDA.1-C Signal Conditioning for Lambda Sensor Simulation must always be removed from the transport packaging, configured and installed at a workstation that is protected from electrostatic discharge.

1.1 Features

The PB1652LAMBDA.1-C Signal Conditioning for Lambda Sensor Simulation is a signal conditioning module for simulating lambda sensors on the ES1652.2 Carrier Board for Signal Conditioning Circuits. The module enables two wide-band and two switching-type sensors to be simulated.

It enables the simulation of the following types of lambda sensor:

- LSU4.x, LSU5.1
- ADV4.2
- LSF4.x
- NTK ZFAS®

The following controllers are supported:

- CJ135STEP1

1.1.1 Using with a Carrier Board

In addition to this module, an analog output and a resistor cascade are required for every lambda sensor simulation (Fig. 1-1).

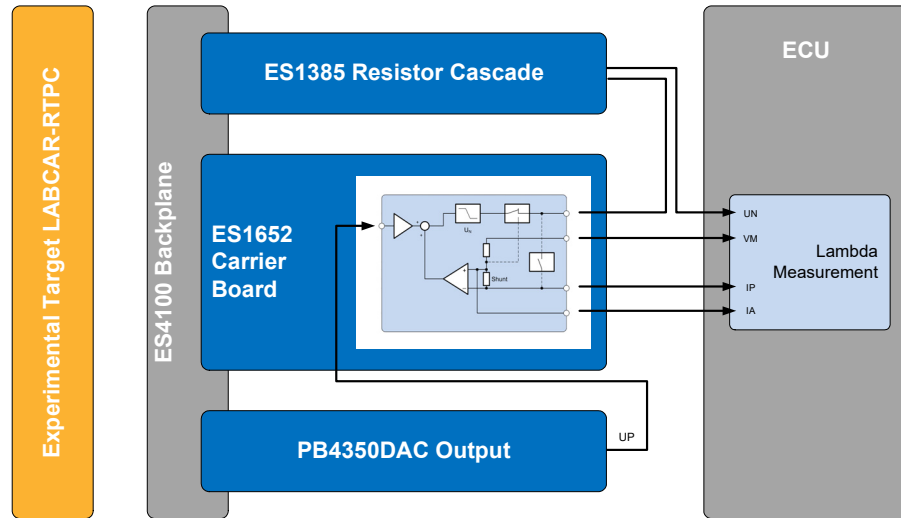

Fig. 1-1 Lambda Sensor Simulation in the HIL System

1.1.2 Block Diagram

The functions of the PB1652LAMBDA.1-C and its inputs and outputs are shown in the following block diagram.

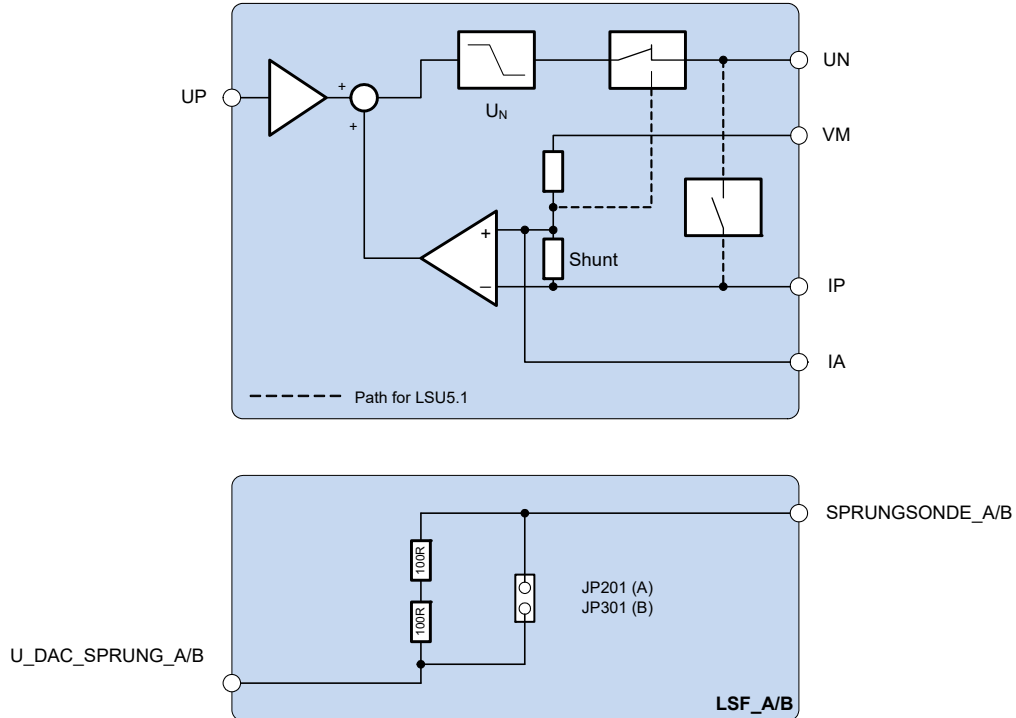

Fig. 1-2 Block Diagram of the PB1652LAMBDA.1-C (Wide-band/Switching-type Sensors)

An explanation of the abbreviations used:

- UP: Pump voltage (from the HIL system)
- UN: Nernst voltage [ECU pin: RE]
- VM: Virtual ground [ECU pin: IPE]
- IP: Pump current [ECU pin: APE]
- IA: Compensating current [ECU pin: MES]

1.2 Basic Safety Instructions

Please adhere to the safety instructions in this manual to avoid injury to yourself and others as well as damage to the device.

1.2.1 Correct Use

ETAS GmbH cannot be made liable for damage which is caused by incorrect use and not adhering to the safety instructions.

1.2.2 Labeling of Safety Instructions

The safety instructions contained in this manual are shown with the standard danger symbol shown below:



The following safety instructions are used. They provide extremely important information. Please read this information carefully.



CAUTION!

indicates a low-risk danger which could result in minor or less serious injury or damage if not avoided.



WARNING!

indicates a possible medium-risk danger which could lead to serious or even fatal injuries if not avoided.



DANGER!

indicates a high-risk, immediate danger which could lead to serious or even fatal injuries if not avoided.

1.3 RoHS conformity

1.3.1 European Union

The EU Directive 2011/65/EU limits the use of certain dangerous materials for electrical and electronic devices (RoHS conformity).

ETAS confirms that the product corresponds to this directive which is applicable in the European Union.

1.3.2 China

ETAS confirms that the product meets the product-specific applicable guidelines of the China RoHS (Management Methods for Controlling Pollution Caused by Electronic Information Products Regulation) applicable in China with the China RoHS marking affixed to the product or its packaging.

1.4 CE marking

ETAS confirms that the product meets the product-specific applicable European Directives with the CE marking affixed to the product or its packaging. The CE Declaration of Conformity for the product is available upon request.

1.5 Taking the Product Back and Recycling

The European Union has passed a directive called Waste Electrical and Electronic Equipment, or WEEE for short, to ensure that systems are set up throughout the EU for the collection, treatment and recycling of electronic waste.

This ensures that the devices are recycled in a resource-saving way representing no danger to health or the environment.



Fig. 1-3 WEEE-Symbol

The WEEE symbol on the product or its packaging shows that the product must not be disposed of as residual garbage.

The user is obliged to collect the old devices separately and return them to the WEEE take-back system for recycling.

The WEEE Directive concerns all ETAS devices but not external cables or batteries.

For more information on the ETAS GmbH Recycling Program, contact the ETAS sales and service locations (see "ETAS Contact Addresses" on page 17).

2 Hardware

This chapter describes the assembly and configuration of the PB1652LAMBDA.1-C Signal Conditioning for Lambda Sensor Simulation.

2.1 Assembly

To assemble the PB1652LAMBDA.1-C module on the ES1652.2 Carrier Board, proceed as follows:

1. Screw the M3x10 metric spacers supplied with the carrier board onto the protruding screws.

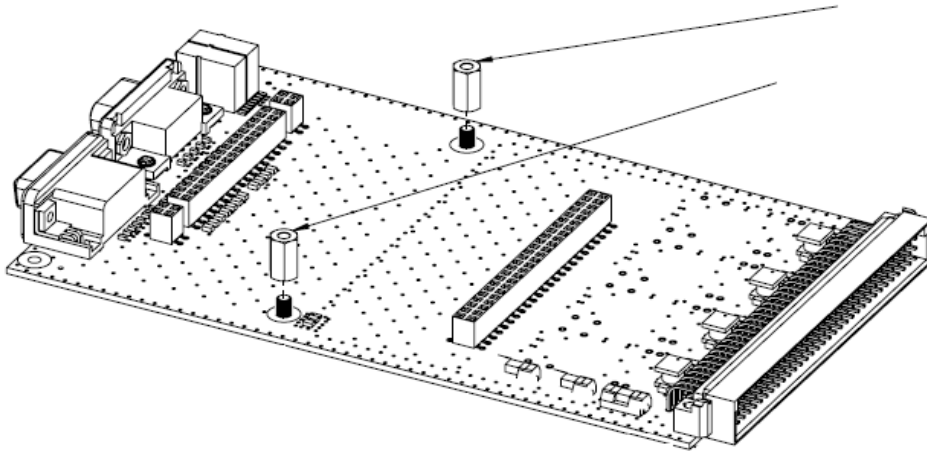

2. Align the pin headers of the module with the female headers of the carrier boards in such a way that they match, i.e. discontinuous pin header on a discontinuous female header and continuous pin header on a continuous female header.
3. Screw the module tight to the carrier board.

2.2 Configuration

2.2.1 Jumpers for Ground Reference

For the analog circuit to work, the analog output board in the HiL must output the voltage with reference to $-UBatt$. The jumpers establish the connection between Ext. GND_CHx and $-UBatt$.

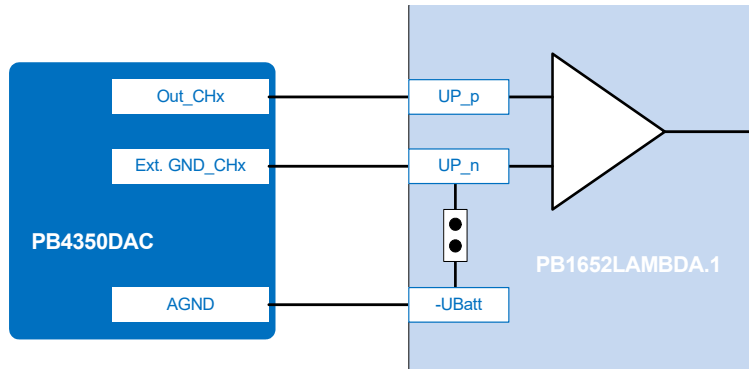

Note

If, in the wiring harness, Ext.GND_CHx of the board is already connected with $-UBatt$, the jumper should be opened!

The jumpers are next to the CO100 pin header.

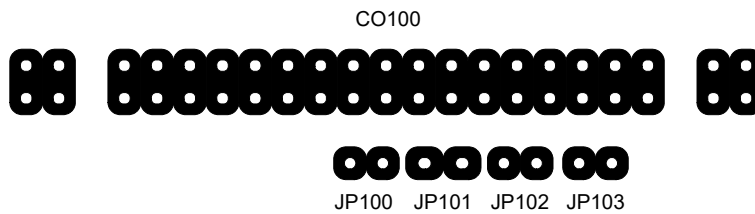

Fig. 2-1 Position of the Jumpers

The functions of the individual jumpers are listed below:

Jumper	Connects	With
JP100	UP_SOLL_N_A* ("IN 6") (wide-band sensor A)	$-UBatt$ ("IN 5")
JP101	UP_SOLL_N_B* ("IN 7") (wide-band sensor B)	$-UBatt$ ("IN 5")
JP102	DAC_SPRUNG_GND_A* "IN 8") (switching-type sensor A)	$-UBatt$ ("IN 5")
JP103	DAC_SPRUNG_GND_B* "IN 9") (switching-type sensor B)	$-UBatt$ ("IN 5")

* A, B specify the two sensors simulated with the module

Tab. 2-1 Function of Jumpers JP100 - JP103

2.2.2 Relays for the Simulation of Wide-Band Sensors of the Type "LSU5.1"

For the simulation of wide-band sensors of the type "LSU5.1", relays on the board have to be switched (see Fig. 1-2 on page 6). For this purpose, 12 V has to be applied at Pin 15 ("RELAY_VCC") of the "OUT 1..15" port (see Tab. 3-2 on page 14).

The relay for wide-band sensor A is switched when Pin 12 ("RELAY_LSW_A") is connected with GND; the relay for wide-band sensor B is switched when Pin 11 ("RELAY_LSW_B") is connected with GND.

2.2.3 Configuration of Switching-Type Sensors

The resistors (200 Ohm) of the switching-type sensors are already present on the modules. External variable resistors can be used by setting the jumpers on the board (P201/JP301 - see Fig. 2-2).

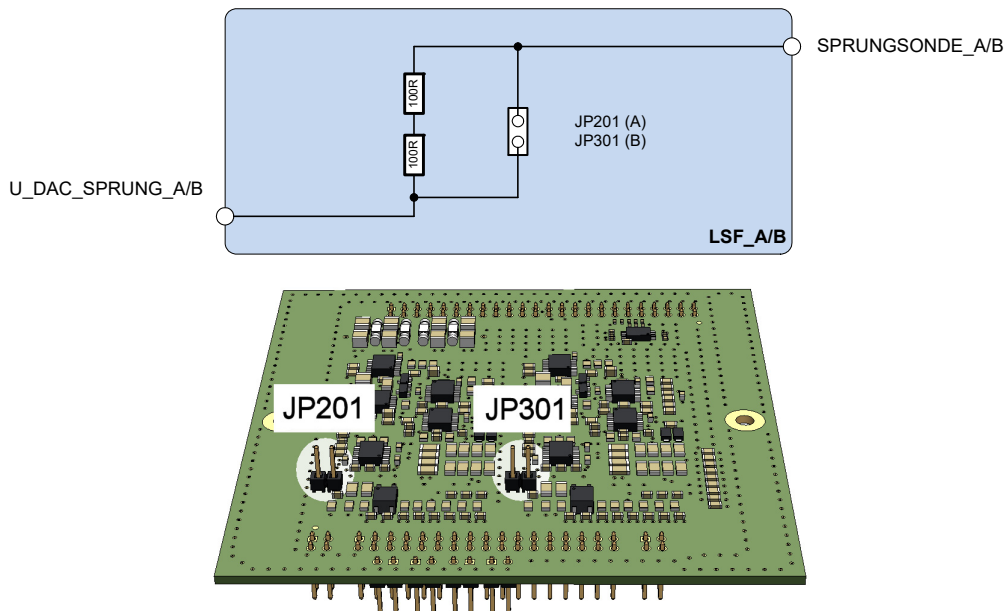

Fig. 2-2 Jumpers for the Resistors of a Switching-Type Sensor

2.2.4 Integration of Lambda Sensor Simulation in LABCAR

The following figure shows an example of how to connect the lambda sensor simulation to LABCAR.

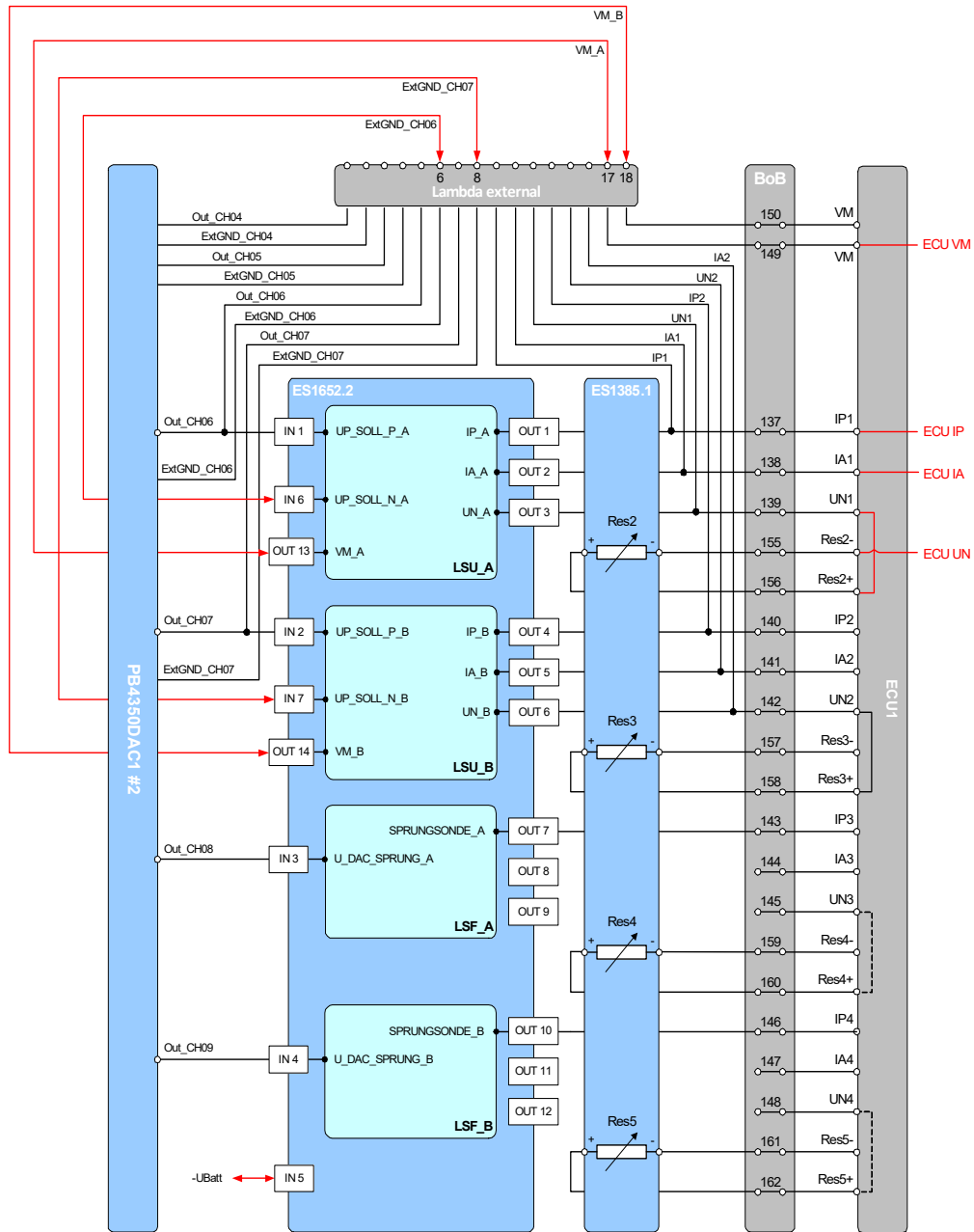

Fig. 2-3 Connection to LABCAR

Note

The connections shown in red must be explicitly established!

3 Pin Assignment and LEDs

Once the PB1652LAMBDA.1-C Signal Conditioning for Lambda Sensor Simulation has been mounted on the ES1652.2 Carrier Board for Signal Conditioning Circuits, the required signals are available over both front-facing connectors.

3.1 Front-Facing Connector of the ES1652.2 Carrier Board

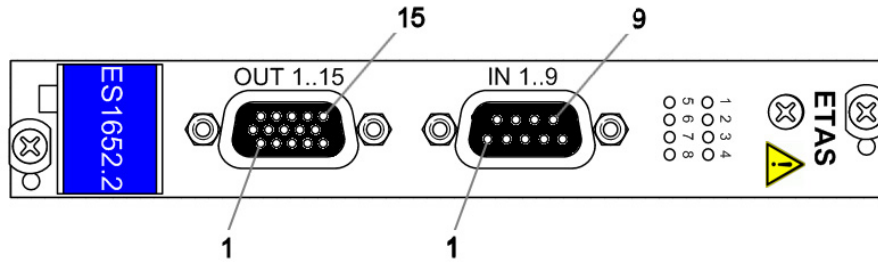

IN 1..9	Signal	CO100 on Carrier Board
1	UP_SOLL_P_A	18
2	UP_SOLL_P_B	17
3	U_DAC_SPRUNG_A	16
4	U_DAC_SPRUNG_B	15
5	-UBatt	14
6	UP_SOLL_N_A	13
7	UP_SOLL_N_B	12
8	DAC_SPRUNG_GND_A	11
9	DAC_SPRUNG_GND_B	10
Housing	Protective earth	

Tab. 3-1 Signals at the "IN 1..9" Connector

Note

To avoid problems with leakage current detection with the CJ135, we recommend using a galvanically isolated, analog output for addressing UP.

OUT 1..15	Signal (Meaning) [ECU Pin]	CO100 on Carrier Board
1	IP_A (pump current sensor A) [APE]	34
2	IA_A (compensating current sensor A) [MES]	33
3	UN_A (Nernst voltage sensor A) [RE]	32
4	IP_B (pump current sensor B) [APE]	31
5	IA_B (compensating current sensor B) [MES]	30
6	UN_B (Nernst voltage sensor B) [RE]	29
7	SPRUNGSONDE_A	28
8	n.c.	27
9	n.c.	26
10	SPRUNGSONDE_B	25
11	RELAY_LSW_B (see section 2.2.2 on page 11)	24
12	RELAY_LSW_A (see section 2.2.2 on page 11)	23
13	VM_A (virtual ground sensor A) [IPE]	22
14	VM_B (virtual ground sensor B) [IPE]	21
15	RELAY_VCC (see section 2.2.2 on page 11)	20
Housing	Protective earth	

Tab. 3-2 Signals at "OUT 1..15" Connector

3.2 LEDs

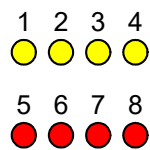

Fig. 3-1 LEDs on the Front Panel of the ES1652.2 Carrier Board

The yellow LEDs always light up when there is a module on the carrier board. The red LEDs are not addressed by the PB1652LAMBDA.1-C.

4 Technical Data

Analog Inputs

Input voltage UP	0...5 V
Input current IP	±3 mA between IP and VM

Analog Outputs

Output voltage UN	0...1 V
Overvoltage protection IP, IA, VM	±12 V for every channel
Usable with ES1652.1 and ES1652.2	Yes

Supported Controllers

CJ135STEP1	LSU4.x, LSF4.x, LSU5.1, ADV4.2, NTK ZFAS®
------------	---

Environmental Conditions

Operating temperature	+5 °C to +50 °C (+41 °F to +122 °F)
Relative humidity	0 to 95% (non-condensing)
Storage temperature	+5 °C to +85 °C (+41 °F to +185 °F)
Relative humidity	0 to 95% (non-condensing)

4.1 Fulfilled Standards and Norms

The PB1652LAMBDA.1-C meets the following norms and standards:

Standard	Test
IEC 61326-1	Electrical equipment for measurement, control and laboratory use – EMC requirements (industrial setting)
IEC 61010-1	Safety requirements for electrical equipment for measurement, control and laboratory use - Part 1: General requirements

The module is only intended for use in industrial settings in accordance with EN 61326-1. Avoid potential radio interference when using the module outside of the industrial settings with additional shielding measures!



WARNING!

This is class A equipment. This equipment can cause radio interference in residential areas. Should that be the case, the operator may be requested to institute reasonable measures.

5 **Ordering Information**

This chapter features the ordering information for the PB1652LAMBDA.1-C as follows:

Order Name	Short Name	Order Number
PB1652LAMBDA.1-C Signal Conditioning for Lambda Sensor Simulation	PB1652LAMBDA.1-C	F-00K-109-934
Scope of Supply	Pieces	
PB1652LAMBDA.1-C Signal Conditioning for Lambda Sensor Simulation	1	

6 **ETAS Contact Addresses**

ETAS HQ

ETAS GmbH

Borsigstraße 24

70469 Stuttgart

Germany

Phone: +49 711 3423-0

Fax: +49 711 3423-2106

WWW: www.etas.com

ETAS Subsidiaries and Technical Support

For details of your local sales office as well as your local technical support team and product hotlines, take a look at the ETAS website:

ETAS subsidiaries WWW: www.etas.com/en/contact.php

ETAS technical support WWW: www.etas.com/en/hotlines.php

Index

A

Assembly 9

B

Block diagram 6

C

CE Declaration of Conformity 8

Configuration 10

Connector "IN 1..9" 13

E

ETAS Contact Addresses 17

F

Features 5

J

Jumpers

for ground reference 10

L

LEDs 14

P

Port "OUT 1..15" 14

Product Back 8

R

Recycling 8

Relays

simulation of wide-band sensors
of the type "LSU5.1" 11

RoHS conformity

China 8

European Union 8

S

Safety instructions, basic 7

Safety instructions, labeling 7

Standards and norms 15

Switching-Type Sensor

Configuration 11

T

Technical data 15

U

Use, correct 7

Using with a carrier board 6

W

Waste Electrical and Electronic Equip-
ment 8

WEEE take-back system 8

