

# ES1335.2 Arbitrary Signal Generator Board

## User's Guide

## Copyright

---

The data in this document may not be altered or amended without special notification from ETAS GmbH. ETAS GmbH undertakes no further obligation in relation to this document. The software described in it can only be used if the customer is in possession of a general license agreement or single license. Using and copying is only allowed in concurrence with the specifications stipulated in the contract.

Under no circumstances may any part of this document be copied, reproduced, transmitted, stored in a retrieval system or translated into another language without the express written permission of ETAS GmbH.

© **Copyright 2018** ETAS GmbH, Stuttgart

The names and designations used in this document are trademarks or brands belonging to the respective owners.

V1.0.0 R03 EN - 07.2018

---

# Contents

<b>1</b>	Introduction . . . . .	5
<b>1.1</b>	Features . . . . .	6
<b>1.2</b>	Applications . . . . .	8
<b>1.3</b>	Block Diagram . . . . .	9
<b>1.4</b>	Taking the Product Back and Recycling . . . . .	11
<b>2</b>	Hardware Features . . . . .	13
<b>2.1</b>	RPM-Generator . . . . .	13
<b>2.1.1</b>	Angular Resolution . . . . .	14
<b>2.1.2</b>	Angle-Specific Speed Modulation (Misfiring Simulation) . . . . .	15
<b>2.2</b>	Arbitrary Signal Generators . . . . .	15
<b>2.2.1</b>	Signal Banks . . . . .	15
<b>2.2.2</b>	Phase Shifts . . . . .	16
<b>2.2.3</b>	Clock Sources . . . . .	16
<b>2.2.4</b>	External Triggers for Speed Generators . . . . .	16
<b>2.3</b>	Knock Signal Generation . . . . .	17
<b>2.4</b>	Output Multiplexer . . . . .	17
<b>2.5</b>	Output Configuration . . . . .	18
<b>3</b>	Pin Assignment and Indicators . . . . .	21
<b>3.1</b>	Pin Assignment . . . . .	21

<b>3.1.1</b>	"Analog Out" Signal Outputs . . . . .	22
<b>3.1.2</b>	"SYNC" Connector for Test Signals . . . . .	23
<b>3.2</b>	Indicators . . . . .	23
<b>4</b>	Accessories . . . . .	25
<b>4.1</b>	AC1335SYNC - Synchronization Unit for ES1334.2 Integration . . . . .	25
<b>4.1.1</b>	Connectors and their Configuration . . . . .	27
<b>4.1.2</b>	Ordering Information . . . . .	29
<b>4.2</b>	PB1335TRIG Trigger Module (6-CH) . . . . .	30
<b>4.2.1</b>	Assembling on the ES1335.2 Arbitrary Signal Generator Board. . . . .	31
<b>4.2.2</b>	Settings in LABCAR-RTC (RTIO Configuration) . . . . .	34
<b>4.2.3</b>	Connectors and their Configuration . . . . .	35
<b>4.2.4</b>	Ordering Information . . . . .	37
<b>5</b>	Technical Data . . . . .	39
<b>6</b>	ETAS Contact Addresses . . . . .	41

## Introduction

---

The ES1335.2 Arbitrary Signal Generator Board is used to stimulate ECUs with speed-synchronous analog and pulse-width modulated signals.

This manual contains the description of the ES1335.2 Arbitrary Signal Generator Board.

This section contains details of the basic functions and area of application of the ES1335.2 Arbitrary Signal Generator Board.



### **CAUTION!**

*Some components of the ES1335.2 Arbitrary Signal Generator Board may be damaged or destroyed by electrostatic discharges. Please keep the board in its storage package until it is installed. The ES1335.2 Arbitrary Signal Generator Board should only be taken from its package, configured and installed at a working place that is protected against static discharge.*



### **WARNING!**

*The components, connectors and conductors of the ES1335.2 Arbitrary Signal Generator Board may carry dangerous voltages. These voltages may even exist when the ES1335.2 is not installed in the ES4100, ES4105 or ES4300 or the ES4100, ES4105 or ES4300 is powered off. Make sure that the ES1335.2 is protected against contact during operation. Disconnect all connections to the ES1335.2 before removing the board.*

## 1.1 Features

---

The ES1335.2 Arbitrary Signal Generator Board has the following features:

- Central crankshaft angle clock generator unit for generating speed-synchronous signals. The maximum speed is 30000 rpm with a resolution of 0.011 °CA.
- Six freely programmable arbitrary signal generators which can be clocked by the central crankshaft generator or by a local clock generator (0 - 1 MHz) (per signal generator)
- There are 12 signal banks available for all signal generators which can be written in real time during runtime.
- Six D/A converters with 10-bit resolution and an output voltage range of -10 V to +10 V (results in 20 mV resolution)
- Every signal generator has an internal or external voltage reference
- Output modes:
  - analog, galvanically isolated
  - digital (open-collector/pull-up, 10 mA), galvanically isolated

The output mode can be changed using software.

- Every output channel has its own galvanic isolation
- Every output channel can be deactivated via software
- Simulation of knock sensors and misfiring simulation possible
- Knock generator with 4 independent outputs
- Synchronization in master/slave operation of up to 19 ES1335.2s possible
- Synchronization of ES1334.2 and ES1334.1 with the optional AC1335SYNC Synchronization Unit for ES1334.2 Integration
- The optional PB1335TRIG Trigger Module enables signal generators to be triggered with external signals.
- Short-circuit-proof and overvoltage proof to  $\pm 60$  V

The following figure shows the front panel of the ES1335.2 Arbitrary Signal Generator Board with

- the LED displays (see "Indicators" on page 23)
- the connector for the signal outputs, external reference voltages and grounds "Analog Out" (see "Analog Out" Signal Outputs" on page 22).
- the test signal output "SYNC" (see "SYNC" Connector for Test Signals" on page 23) for outputting crankshaft angle clock signals, for example on an oscilloscope.

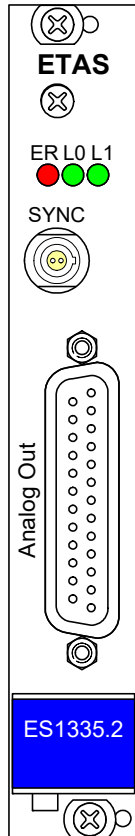

**Fig. 1-1** Front Panel of the ES1335.2 Arbitrary Signal Generator Board

## 1.2 Applications

---

The ES1335.2 Arbitrary Signal Generator Board can be used in the VMEbus systems

- ES4100
- ES4105
- ES4300

wherever freely programmable analog signal traces with different frequencies, amplitudes and pulse widths are required.

The ES1335.2 Arbitrary Signal Generator Board is used to generate the following vehicle signals:

- Speed-synchronous signals
  - Speed signal (is used by the engine ECU to acquire the speed and the crankshaft angle)
  - Camshaft signal (the camshaft signal is required by the ECU for cylinder recognition)
- Pulse-width modulated signals
  - Wheel rotation speed signal (simulation of vehicle speed)
  - Pedal value signal (simulation of accelerator, clutch and brake)
- Simulation of four independent knock sensors
- Misfiring simulation



### 1.3 Block Diagram

Fig. 1-2 shows a block diagram with all important functional units of the ES1335.2 Arbitrary Signal Generator Board.

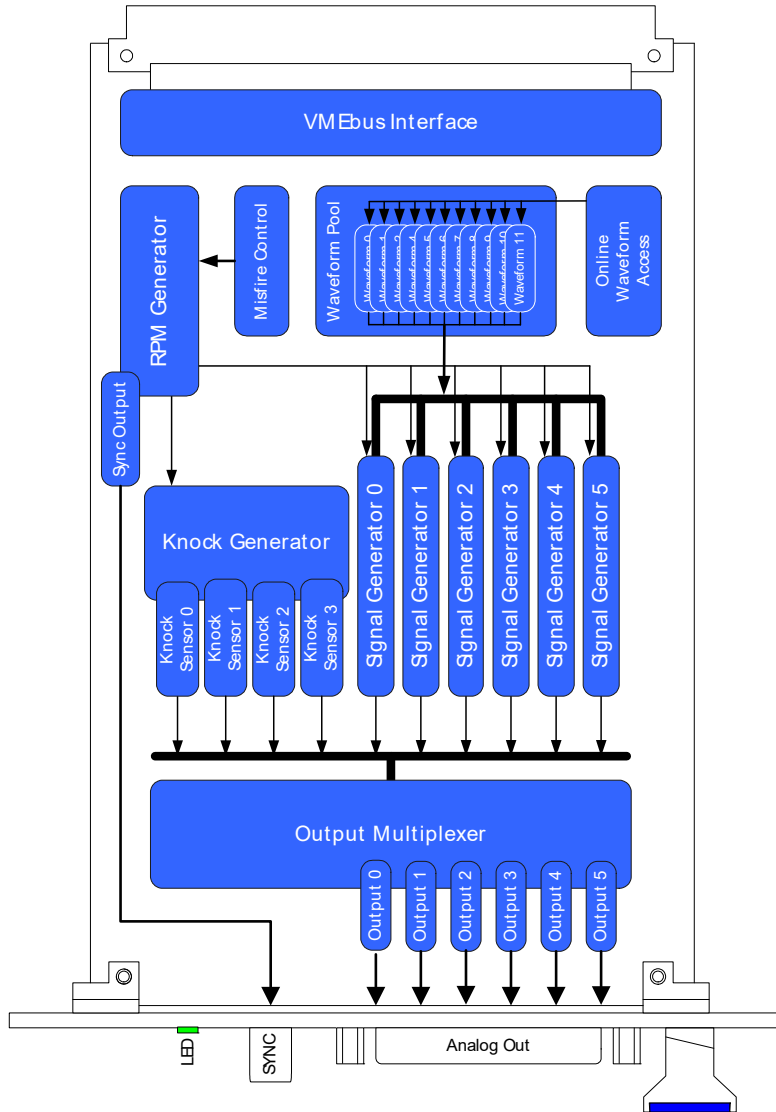

**Fig. 1-2** Block Diagram of the ES1335.2 Arbitrary Signal Generator Board

The ES1335.2 Arbitrary Signal Generator Board has six signal outputs which can be used flexibly – every output can be assigned one of the available internal signals. The outputs of six arbitrary signal generators and of a knock generator with four internal outputs are available as internal signals.

The six arbitrary signal generators can be timed using a central speed generator (RPM generator) or an individual local frequency. An individual phase shift is possible with each of the arbitrary signal generators.

There are twelve signal banks available centrally any of which can be read out and output by the six signal generators. The maximum resolution is 65536 data points. The signal banks can be written online (from the running simulation model).

The speed can be modulated via misfire control. This makes angle-related speed variations possible which enables misfiring to be simulated, for example.

The knock signal generator generates the structure-borne noise which occurs with a combustion engine due to knocking. The frequency and envelope curve of the knock signal can be configured. A cylinder-specific assignment to one of four internal outputs of the knock signal generator makes it possible to simulate knock signals of more complex engines.

Up to twelve cylinders are supported both with misfiring and with the knock signal generator.

## 1.4 Taking the Product Back and Recycling

---

The European Union has passed a directive called Waste Electrical and Electronic Equipment, or WEEE for short, to ensure that systems are setup throughout the EU for the collection, treating and recycling of electronic waste.

This ensures that the devices are recycled in a resource-saving way representing no danger to health or the environment.



**Fig. 1-3** WEEE Symbol

The WEEE symbol on the product or its packaging shows that the product must not be disposed of as residual garbage.

The user is obliged to collect the old devices separately and return them to the WEEE take-back system for recycling.

The WEEE directive concerns all ETAS devices but not external cables or batteries.

For more information on the ETAS GmbH Recycling Program, contact the ETAS sales and service locations (see "ETAS Contact Addresses" on page 41).



## 2 Hardware Features

---

This chapter contains information on the features of the ES1335.2 Arbitrary Signal Generator Board.

### 2.1 RPM-Generator

---

The ES1335.2 Arbitrary Signal Generator Board has a central speed generator (RPM Generator) which outputs an engine-speed-specific clock signal. This clock signal can be used by the signal generators to read out and output the signal banks. The maximum speed is 30000 rpm, the resolution around 0.001 rpm. The speed signal itself can be modulated using a misfiring generator.

An angle- or speed-based synchronization of several ES1335.2 Arbitrary Signal Generator Boards is possible. For this purpose, one ES1335.2 is configured as RPM master; all other ES1335.2s are configured as RPM slaves. The master board outputs the crankshaft angle to the backplane of the VMEbus system, from where it is tapped by the slave boards.

The crankshaft angle clock signal consists of three signals (see Fig. 2-1):

- The synchronization signal at 0 °CA
- The actual clock signal
- The signal for the direction of rotation (DOR)

A "high" level DOR signal means "rotation with increasing crankshaft angle"; a "low" level means "rotation with decreasing crankshaft angle".

One of these three clock signals can be output using a multiplexer at the "SYNC" connector on the front panel (see "SYNC" Connector for Test Signals" on page 23). This makes it possible to acquire a clock signal with an oscilloscope or to trigger external hardware angle-synchronously.

The following figure shows the three individual signals during one rotation of the camshaft.

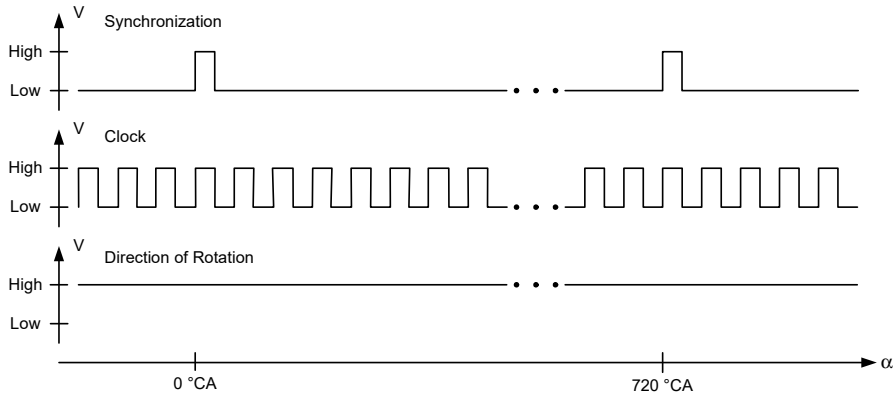

**Fig. 2-1** The Three Components of the Crankshaft Clock Signal

### 2.1.1 Angular Resolution

The crankshaft angle is calculated on every edge (rising or falling) of the clock signal. The angular resolution is thus determined by the number of edges of the clock signal – this number  $n_{\text{edges}}$  is an RTIO parameter and can be selected (in powers of two) from 16 to  $2^{16} = 65536$ .

The angular resolution  $\Delta\alpha$  is then:

$$\Delta\alpha = \frac{720^\circ}{n_{\text{edges}}}$$

There is thus a maximum angular resolution of 0.011 °CA for the maximum number of edges. The maximum speed with this resolution is 30000 rpm.

The discrete crankshaft angles can be calculated using the following equation:

$$\alpha_v = \frac{v \cdot 720^\circ}{n_{\text{edges}}} \quad (0 \leq v < n_{\text{edges}})$$

## 2.1.2 Angle-Specific Speed Modulation (Misfiring Simulation)

The term "speed modulation" is a general term for speed variations which can occur due to misfiring or during the normal four-stroke cycle of a combustion engine.

The speed variations which occur are described using a modulation profile  $\delta(\alpha)$ , in which  $\alpha$  is the crankshaft angle (0 to 720°) and  $\delta$  the relative deviation from the target speed  $n_0$  (see Fig. 2-2).

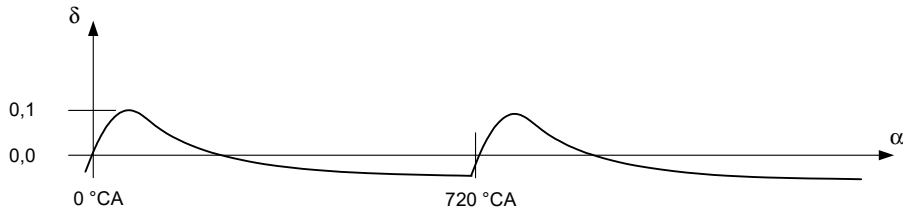

**Fig. 2-2** Modulation Profile of the Engine Speed

If the phase shifts  $\alpha_i$  between the individual cylinders are taken into consideration, the resulting engine speed  $n(\alpha)$  is as follows with a crankshaft angle of  $\alpha$ :

$$n(\alpha) = n_0 \cdot \prod_{I=1}^{m_z} [1 + \delta(\alpha - \alpha_I) \cdot d_I]$$

$m_z$  is the number of cylinders and  $d_i$  a cylinder-specific attenuation coefficient between 0.0 and 1.0. This coefficient simulates differences between the cylinders due to fabrication tolerances, deterioration and abrasion.

## 2.2 Arbitrary Signal Generators

There are six arbitrary signal generators available on the ES1335.2 Arbitrary Signal Generator Board. Each of these signal generators can read out and output one of the twelve signal banks available centrally.

### 2.2.1 Signal Banks

In the ES1335.2 there are twelve signal banks available with up to  $2^{16}$  points which can be used by the six arbitrary signal generators. The signal banks can be written by the user via tables – the signal trace is written to the table of the relevant signal bank in an interpolation procedure.

All 12 signal traces have the same length (signal length = number of points the signal bank consists of) corresponding to the angular resolution. If, for example, a resolution of 65536 clock pulses per camshaft revolution is specified, all signals consist of 65536 points.

The values of the signal bank are written with integers with a sign (16 bit) – the user specifies the values using floating-point numbers normalized to the interval [-1.1].

### *Amplitudes*

---

The value of the analog signal which is ultimately available at the signal output is created by multiplying the angle-specific signal bank value with an amplitude value. The amplitude value is channel-specific and is specified normalized to [0 ,1].

If the internal voltage reference of 10 V is used, the normalized value 1.0 corresponds to an output voltage  $V_{out}$  of 10 V; when using an external reference voltage  $V_{ext}$ , the normalized value 1.0 corresponds to an output voltage  $V_{out} = V_{ext}$ .

### 2.2.2 Phase Shifts

---

It is possible to modify the signal output of a signal generator with regard to its phase relation. A target phase specified by the user is not immediately accepted by the hardware but is started with a phase change speed (in °CA/s) specified by the user. This avoids phase jumps which could result in error entries in the ECU.

### 2.2.3 Clock Sources

---

There are two possible clock sources for the signal generators:

- The central crankshaft angle clock generator (see section 2.1 on page 13), whose clock applies to all signal generators.
- A local clock generator with variable frequency (max. 1 MHz)

There is a separate local clock generator available for every signal generator.

### 2.2.4 External Triggers for Speed Generators

---

The optional PB1335TRIG Trigger Module (see "PB1335TRIG Trigger Module (6-CH)" on page 30) allows one or more signal generators to be triggered with external signals.



## 2.3 Knock Signal Generation

The knock signal generator unit enables the simulation of four knock sensors. The knock angle, i.e. the angle at which the knock signal is generated, is thus the same for all four sensors. These knock angles are usually identical to the ignition angles of the cylinders.

Every knock sensor can be configured so that it detects a structure-borne noise coming from a specific cylinder (or not). If the sensor detects the knocking of a cylinder, the sensor outputs a knock package every time the crankshaft angle is the same as the ignition angle of this cylinder. If the sensor does not detect the knocking of a cylinder, no knock package is output.

In the following figure, knock sensor #0 detects the knocking from cylinders 0 and 2, knock sensor #1 the knocking from cylinders 1 and 3. Knock sensors #2 and #3, on the other hand, detect knocking from all four cylinders.

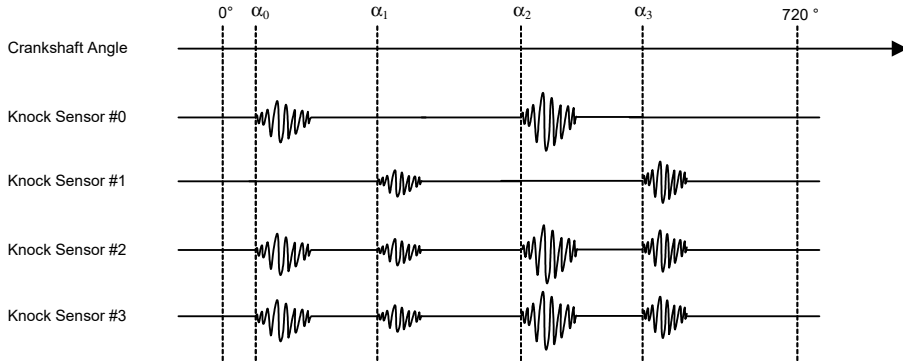

The knock signal generator unit supports engines with up to 12 cylinders. The knock signal is stored in a separate signal bank and read out and output with a frequency of 1 MHz.

Please note that this signal bank is not one of the twelve signal banks of the arbitrary signal generators. The signal bank has a length of  $2^{16}$  points so that knock signals with a length of up to  $2^{16}$   $\mu$ s can be read out and output.

The knock curve, the knock angles and knock signal amplitudes are identical for all four knock sensors.

## 2.4 Output Multiplexer

The output multiplexer enables the assignment of the internal signals (of the six arbitrary signal generators and four knock sensors) to the six available physical outputs of the ES1335.2. It is possible to apply an internal signal to several outputs.

## 2.5 Output Configuration

Each of the six outputs of the ES1335.2 Arbitrary Signal Generator Board can be configured according to whether it

- uses the internal voltage reference (10 V) or a reference voltage applied from outside.
- issues an analog signal or a digital signal derived from the output voltage.

The digital signal is derived from the analog signal when the analog output value in the FPGA is routed to a comparator. The comparator threshold corresponds to 1 V when the internal reference is used or  $0.1 \times V_{\text{ext}}$  when the external reference is used.

- is used as an open-collector output or as an open-collector output with pull-up functionality when the digital output is used.
- is deactivated completely.

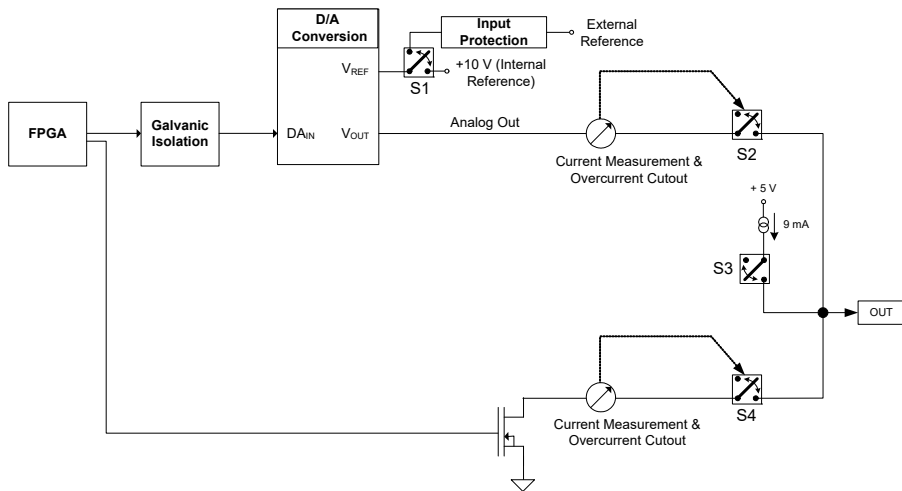

**Fig. 2-3** Schematic of a DA Channel

### *Overcurrent Cutout*

---

The currents through the analog and digital output stage are measured and interrupted if the current through the analog output stage exceeds 33 mA or if the current through the digital output stage exceeds 115 mA.

### *Pin Assignment*

---

For more details on the pin assignment of the connectors for the signal outputs, refer to "Analog Out" Signal Outputs" on page 22.



### 3 **Pin Assignment and Indicators**

---

This chapter contains the description of the pin assignment of the connectors and the indicators of the ES1335.2 Arbitrary Signal Generator Board. It consists of the following sections:

- Pin Assignment (section 3.1 on page 21)  
This describes the pin assignment of all the connectors on the front panel.
- Indicators (section 3.2 on page 23)  
This section describes the meaning of the LED displays on the front panel.

#### 3.1 **Pin Assignment**

---

This section describes the pin assignment of the connectors for the signal output, test outputs and for the inputs for external signals:

- " "Analog Out" Signal Outputs" on page 22
- " "SYNC" Connector for Test Signals" on page 23

### 3.1.1 "Analog Out" Signal Outputs

The connector for the signal outputs, external reference voltages and analog ground is a D-Sub 25 connector (female). The shielding is at front panel and housing potential and thus at protective earth.

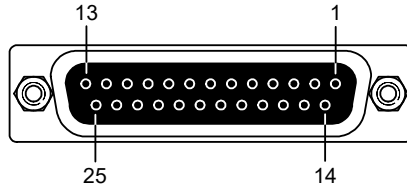

**Fig. 3-1** "Analog Out" Connector

Pin	Signal	Pin	Signal
1	Channel #0 Output	14	Channel #0 Analog Ground
2	Channel #0 External Reference	15	Channel #0 Analog Ground
3	Channel #1 Output	16	Channel #1 Analog Ground
4	Channel #1 External Reference	17	Channel #1 Analog Ground
5	Channel #2 Output	18	Channel #2 Analog Ground
6	Channel #2 External Reference	19	Channel #2 Analog Ground
7	Channel #3 Output	20	Channel #3 Analog Ground
8	Channel #3 External Reference	21	Channel #3 Analog Ground
9	Channel #4 Output	22	Channel #4 Analog Ground
10	Channel #4 External Reference	23	Channel #4 Analog Ground
11	Channel #5 Output	24	Channel #5 Analog Ground
12	Channel #5 External Reference	25	Channel #5 Analog Ground
13	n.c.		

**Tab. 3-1** Pin Assignment of the "Analog Out" Connector

### 3.1.2 "SYNC" Connector for Test Signals

Jack Type LEMO 2-pin. Type: XBG.00.302 NLN (female)

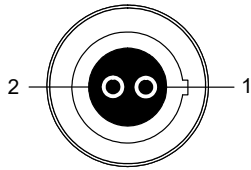

**Fig. 3-2** "SYNC" Connector

Pin	Assignment	Pin	Assignment
1	Sync Signal Output	Shielding	Protective conductor
2	VMEbus Ground		

**Tab. 3-2** Pin Assignment of the "SYNC" Connector

## 3.2 Indicators

There are several LEDs on the front panel of the ES1335.2 Arbitrary Signal Generator Board, the meaning of which is described in this section.



**Fig. 3-3** The LED Field on the Front Panel

LED	Display	Meaning
ER	LED lights up red	Error (e.g. ROM data damaged, board not calibrated or calibration data damaged, ROM access failed)
L0	LED flashes green	1 Hz blink frequency indicates correcting functioning of the system CPU
L1	LED flashes green	1 Hz blink frequency indicates correcting functioning of the system CPU

**Tab. 3-3** Meaning of the LEDs





## 4 Accessories

---

There are two accessory cards for the ES1335.2 Arbitrary Signal Generator Board;

- **AC1335SYN Synchronization Unit for ES1334.2 Integration**

This is used to route the CAC signals (generated by a master) from the backplane of the system to the front panel (see "AC1335SYNC - Synchronization Unit for ES1334.2 Integration" on page 25).

- **PB1335TRIG Trigger Module**

This is used to trigger signal generators of the ES1335.2 by external trigger signals or a battery voltage (see "PB1335TRIG Trigger Module (6-CH)" on page 30).

### 4.1 AC1335SYNC - Synchronization Unit for ES1334.2 Integration

---

The Synchronization Unit for ES1334.2 Integration is used as a splitter for CAC signals (CAC = crankshaft angle clock): it taps the CAC signals (generated by the ES1335.2 Arbitrary Signal Generator Board configured as master) from the backplane and routes them to the front panel. These signals can be transferred to ES1334 Measurement Boards for their synchronization.

The Synchronization Unit for ES1334.2 Integration is a VMEbus board (3 U) for systems with VME64x backplanes such as the ES4100, ES4105 and the ES4300.

#### **Note**

---

*The board cannot be used in systems with standard 96 pin backplanes as the CAC signals do not exist on these backplanes.*

#### *Front Panel*

---

The corresponding connectors are on the front panel of the board: The "Sync" and "Clk" connectors are each test outputs which are used to monitor the synchronization and clock signal.

Certain parts of the CAC signal are made available by the ES1335.2 for the ES1334.1 Measurement Boards via the "CACx" (x = 0, 1, 2, 3) connector.

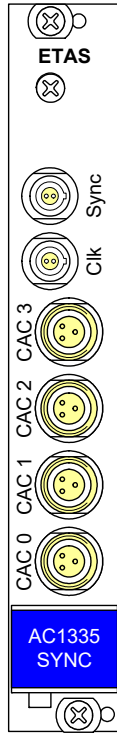
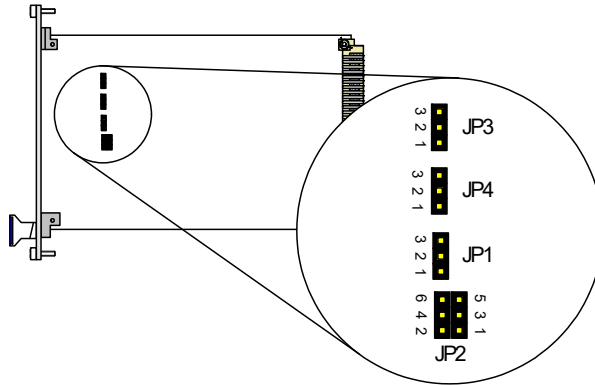

**Fig. 4-1** Front Panel

## 4.1.1 Connectors and their Configuration

There are several jumpers on the AC1335SYNC Board (see Fig. 4-2) which are used to determine which signals are routed to the front panel connectors.

### *Jumpers for Connector Configuration*



**Fig. 4-2** Position and Name of the Jumpers on the Board

### *"Sync" Connector for Synchronization Signals*

Jack Type LEMO 2-pin. Type: XBG.00.302 NLN (female)

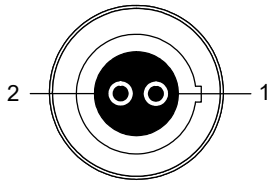

**Fig. 4-3** "Sync" Connector

Pin	Signal
1	JP3: Position 1-2: CAC synchronization signal (default) (5 V) JP3: Position 2-3: CAC direction of rotation signal (DOR) (5 V)
2	VMEbus ground

**Tab. 4-1** Pin Assignment of the "Sync" Connector

The correct cable for this connector is the "K98" cable (see "Ordering Information" on page 29).

### *"Clk" Connector for Clock Signals*

---

Jack Type LEMO 2-pin. Type: XBG.00.302 NLN (female)

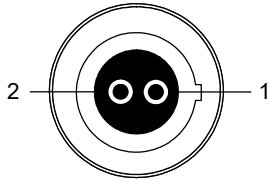

**Fig. 4-4** "Clk" Connector

Pin	Signal
1	JP4: Position 1-2: CAC clock signal (default) (5 V) JP4: Position 2-3: CAC direction of rotation signal (DOR) (5 V)
2	VMEbus ground

**Tab. 4-2** Pin Assignment of the "Clk" Connector

The correct cable for this connector is the "K98" cable (see "Ordering Information" on page 29).

### *"CAC x" Connector for Crankshaft Angle Clock Signals*

---

Jack Type LEMO 3-pin. Type: EXG.0B.303.HLN (female).

Appropriate mating connector: FGG.0B.303.CLAD52ZN.

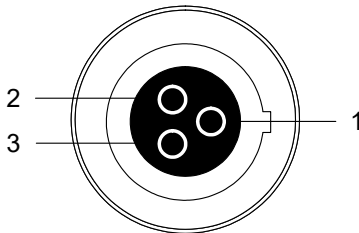
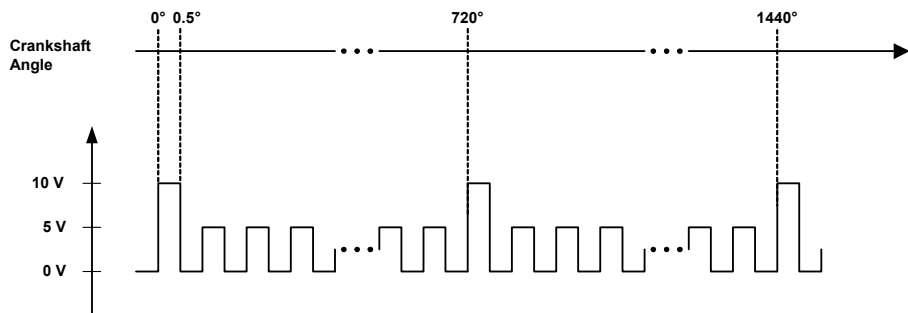

**Fig. 4-5** "CAC x" (x = 0, 1, 2, 3) Connector

Pin	Signal
1	JP1: Position 1-2: ES1334-compatible, combined synchronization and clock signal (see Fig. 4-6) (default) JP1: Position 2-3: CAC clock signal (5 V)
2	JP2: Position 1-2: VMEbus ground (default) JP2: Position 3-4: CAC direction of rotation signal (DOR) (5 V) JP2: Position 5-6: CAC synchronization signal (5 V)
3	VMEbus ground

**Tab. 4-3** Pin Assignment of the "CAC x" (x = 0, 1, 2, 3) Connectors

The following figure shows the trace of the combined synchronization and clock signal output at Pin 1 – with corresponding setting of the connectors – which is meant for the synchronization of connected ES1334 Measurement Boards.



**Fig. 4-6** ES1334-Compatible Synchronization and Clock Signal

#### 4.1.2 Ordering Information

Order Name	Short Name	Order Number
Synchronization Unit for ES1334.2 Integration	AC1335SYNC	F-00K-104-886
Cable for P7AI and P8AO Lemo - BNC, 1m	K98	F-00K-000-656

## 4.2 PB1335TRIG Trigger Module (6-CH)

---

The signal generators of the ES1335.2 Arbitrary Signal Generator Board are started when the central CAC generator or the relevant local clock generator output 0° CA (see "Arbitrary Signal Generators" on page 15).

The PB1335TRIG Trigger Module now makes it possible to trigger one or more signal generators of the ES1335.2 using six external trigger signals.

The trigger threshold is selected using a jumper strip on the trigger module – the trigger signals are assigned to the signal generators in LABCAR-RTC.

The PB1335.1TRIG Trigger Module is installed by screwing it onto the ES1335.2 Arbitrary Signal Generator Board.

### *Front Panel*

---

The external trigger signals are applied at connector "TRIG 0-5" on the front panel.



**Fig. 4-7** Front Panel



### *Attaching the Rear Spacers*

---

Reattach the connector strip by attaching two spacers of type "M2.5 x 12.72 SW5" (on the component side) with two of the "M2.5 x 14" screws (see Fig. 4-9).

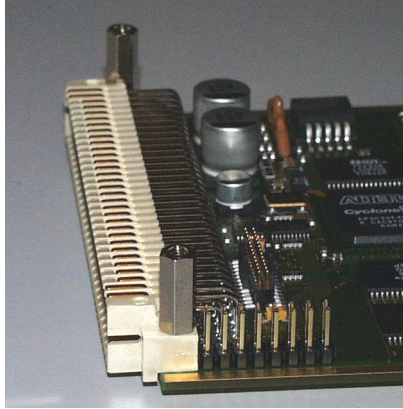

**Fig. 4-9** Spacers on the Connector Strip

### *Attaching the Front Spacer*

---

Replace the screw for the upper fastening of the front panel to the circuit board with one of the 14 mm ones supplied (arrow in Fig. 4-10 on the left).

Attach the spacer of type "M2.5 \* 11.5 SW4" to the visible excess thread (on the component side) (Fig. 4-10 on the right)

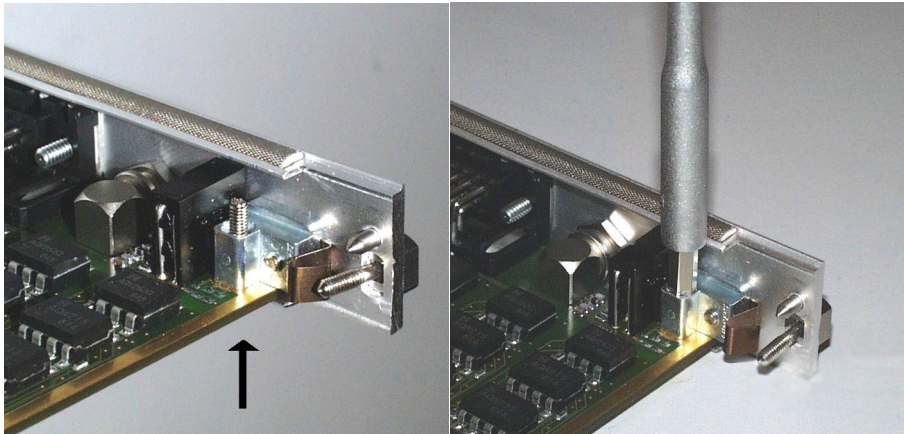

**Fig. 4-10** Replacing the Upper Front Panel Fastening



You have now completed preparing the attachment of the PB1335TRIG module.

#### *Preparing the PB1335TRIG Module*

---

Remove the upper screw with which the front panel is attached to the circuit board (upper arrow in Fig. 4-11).

Then remove the Euroboard from the front panel by removing the relevant screw (lower arrow in Fig. 4-11).

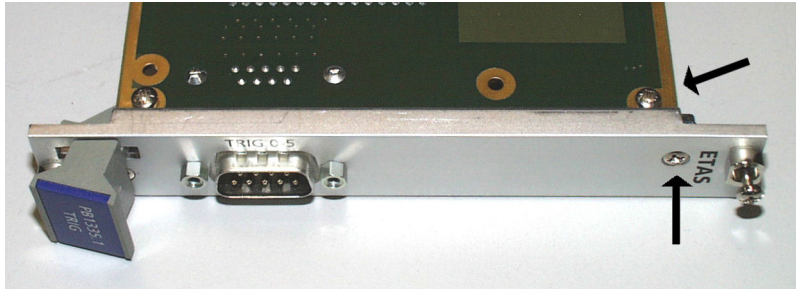

**Fig. 4-11** Screws for the Upper Front Panel Fastening

Replace the spacer removed with the one supplied and reattach this to the front panel (lower arrow in Fig. 4-11).

#### *Assembling the PB1335TRIG Module on the ES1335.2*

---

Place the PB1335TRIG Module on the ES1335.2 by connecting the two-row contact strip of the PB1335TRIG Module with the relevant pin strip on the ES1335.2.

Attach to the three spacers with the three remaining screws.

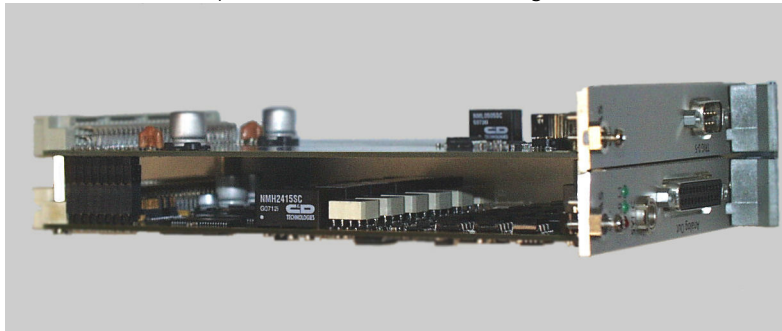

**Fig. 4-12** PB1335TRIG assembled on the ES1335.2

## 4.2.2 Settings in LABCAR-RTC (RTIO Configuration)

Please read the following instructions on configuring the ES1335.2 in LABCAR-RTC.

### *ES1335-Powertrain Subsystem*

When configuring the ES1335-Powertrain Subsystem, values of the “Waveform Table *n*” options should correspond to the value of “Resolution” as this results in the signal defined by the “Waveform Table *n*” only being output once.

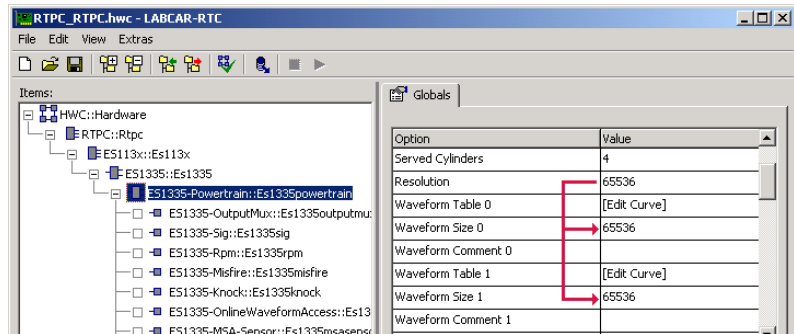

### *ES1335-Sig Device*

In the ES1335-Sig Device, set the following signals to the values specified:

- ClockSource = 1  
The local clock signal is used
- TriggerMode  
The trigger works in “Single-Shot” mode

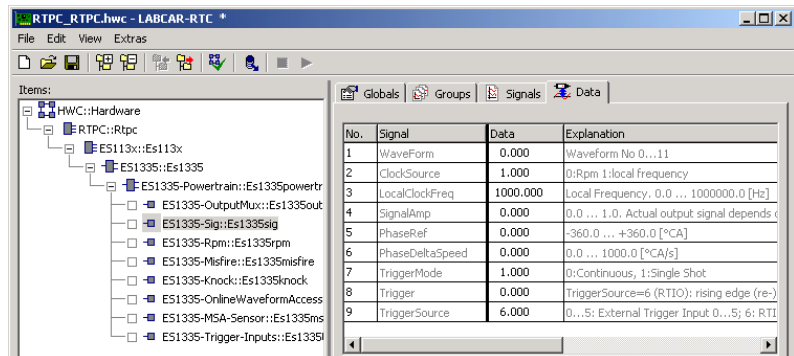

### 4.2.3 Connectors and their Configuration

The trigger signals (and a battery voltage) are applied at the connector on the front panel – the trigger threshold is configured using a jumper strip on the trigger module.

TRIG 0-5

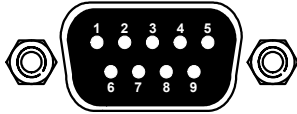

**Fig. 4-13** TRIG 0-5

Type: 9-pin DSUB (male)

Mating connector: 9-pin DSUB (female)

The pin assignment is as follows:

Pin	Signal	Pin	Signal
1	TriggerSource0	6	TriggerSource5
2	TriggerSource1	7	-UBatt
3	TriggerSource2	8	-UBatt
4	TriggerSource3	9	+UBatt
5	TriggerSource4	Housing	Protective earth

**Tab. 4-4** Pin Assignment of TRIG 0-5

All connectors are galvanically isolated both from the ES1335.2 Arbitrary Signal Generator Board and from the VMEbus.

#### **Note**

*The signals connected to the trigger inputs always refer to the potential – UBatt. –UBatt therefore always has to be connected to the reference ground of the external trigger source!*

## Jumpers for Configuring Trigger Sources

There is a jumper strip on the PB1335TRIG Module (see Fig. 4-14) with which the trigger threshold valid for all six inputs can be selected.

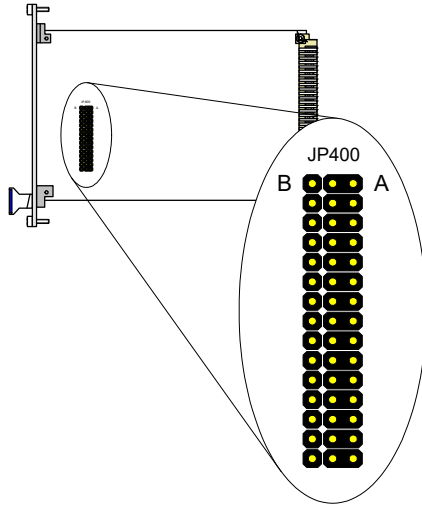

**Fig. 4-14** The Jumper Strip for Configuring the Trigger Thresholds

The jumpers connect either the middle row with the right-hand row (Position A) or the middle row with the left-hand one (Position B).

The jumper position has the following meaning:

- Position A  
The battery voltage  $+U_{\text{Batt}}$  applied from outside determines the trigger threshold. This position should be selected for signal levels between 5 V and 60 V. For typical values for trigger thresholds and hysteresis, see Tab. 4-5.
- Position B  
This position should be used for trigger signals with a level of 5 V. A trigger signal will definitely be detected from an active signal level of 3 V.

### **Note**

*If the outputs "DIAG 0" – "DIAG 7" of the ES1336 are used as trigger sources, select Position B.*

<b>U_Batt</b>	<b>Rising Edge Threshold</b>	<b>Falling Edge Threshold</b>
6 V	4.7 V	2.9 V
8 V	5.7 V	3.9 V
10 V	6.7 V	4.9 V
15 V	9.1 V	7.4 V
20 V	11.7 V	10.0 V
30 V	16.7 V	15.2 V
40 V	21.8 V	20.1 V
50 V	26.7 V	25.2 V
60 V	31.8 V	30.3 V

**Tab. 4-5** Typical Trigger Thresholds

#### 4.2.4 Ordering Information

<b>Order Name</b>	<b>Short Name</b>	<b>Order Number</b>
PB1335TRIG Trigger Module (6-CH)	PB1335TRIG.1	F-00K-106-277



## 5

**Technical Data***Analog Output Stage*

External reference voltage	-10 V ... +10 V
Output voltage range	-10 V ... +10 V (internal reference) -V <sub>ext</sub> ... +V <sub>ext</sub> (external reference)
Output frequency	1 MHz max.
Accuracy	With internal reference: Typical: ±5 mV (20 °C/68 °F, without load) Guaranteed: ± 20 mV (20 °C/68 °F, without load)  With external reference: Typical: 12 bit (20 °C/68 °F, without load) Guaranteed: 10 bit (20 °C/68 °F, without load)
Output current	Typical: ±36 mA (20 °C/68 °F) Guaranteed: ±30 mA (20 °C/68 °F)
Overvoltage protection	±60 V
Galvanic isolation	Yes

*Digital Output Stage*

Rise time	Typical: 1 µs (20 °C/68 °F, 1 nF load) Guaranteed: 2.0 µs (20 °C/68 °F, 1 nF load)
Fall time	Typical: 50 ns (20 °C/68 °F, 1 nF load) Guaranteed: 2.0 µs (20 °C/68 °F, 1 nF load)
Internal pull-up functionality	Power source, current 9.5 mA typical
Output voltage (internal pull-up)	5 V
Output current	Typical: 120 mA (20 °C/68 °F) Guaranteed: 100 mA (20 °C/68 °F)
Overvoltage protection	±60 V
Galvanic isolation	Yes

### *Electrical Data*

---

Current consumption	10 mA @ +5 V DC
	160 mA @ +12 V DC
	160 mA @ -12 V DC
	700 mA @ +3.3 V DC

---

### *Environmental Conditions*

---

Operating temperature	5 °C to 35 °C (41 °F to 95 °F)
Relative humidity	0 to 95% (non-condensing)

---



## 6

### ETAS Contact Addresses

---

#### *ETAS HQ*

---

ETAS GmbH

Borsigstraße 24

70469 Stuttgart

Germany

Phone: +49 711 3423-0

Fax: +49 711 3423-2106

WWW: [www.etas.com](http://www.etas.com)

#### *ETAS Subsidiaries and Technical Support*

---

For details of your local sales office as well as your local technical support team and product hotlines, take a look at the ETAS website:

ETAS subsidiaries

WWW: [www.etas.com/en/contact.php](http://www.etas.com/en/contact.php)

ETAS technical support

WWW: [www.etas.com/en/hotlines.php](http://www.etas.com/en/hotlines.php)



---

# Index

## A

AC1335SYNC 25  
    configuration 27  
    connectors 27  
    jumpers 27  
Accessories 25  
Angular resolution 14  
Applications 8

## B

Block diagram 9

## C

Clock sources 16

## E

ETAS Contact Addresses 41

## F

Features 6  
Front panel 7

## I

Indicators 23

## J

Jumpers  
    AC1335SYNC 27  
    PB1335TRIG 36

## K

Knock signal generation 17

## M

Misfiring  
    speed modulation 15

## O

Output configuration 18  
Output multiplexer 17  
Overcurrent cutout 19

## **P**

- PB1335TRIG
  - configuration 35
  - connectors 35
  - jumpers 36
- Phase shifts 16
- Pin assignment 21
  - “SYNC” 23
  - Analog Out 22
  - signal outputs 22
- Product Back 11

## **R**

- Recycling 11

## **S**

- Signal banks 15
- Signal generators
  - arbitrary 15
- Speed generator 13
- Speed modulation
  - misfiring 15
- Synchronization Unit for ES1334.2 Integration 25

## **T**

- Technical Data 39

## **W**

- Waste Electrical and Electronic Equipment 11