

ES1651.1-B Carrier Board (4 Sockets)

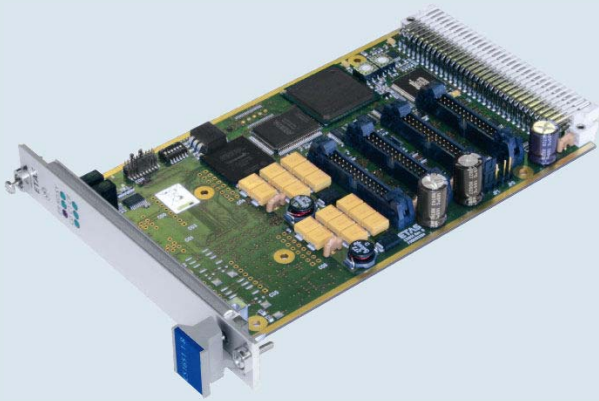

Key Features

- Carrier board for up to four I/O modules of type PB1651xxx and PB4350xxx



ETAS Group
Automotive LifeCycle
Solutions

Applications

The ES1651.1-B Carrier Board acts as a carrier board for up to four I/O modules in VMEbus systems. All modules of types PB4350xxx and PB1651xxx can be used in any combination.

An SPI control unit realized in the FPGA of the board converts the parallel data flow of the processor into a serial bit flow for the SPI interfaces of the I/O modules.

Software Control Interface

The ES1651.1-B Carrier Board is completely configurable and controllable by software. This software control interface, LABCAR-RTC (Real-Time Execution Connector) is supported by LABCAR-OPERATOR V3.2.5 and higher.

The software supports up to 20 ES1651 boards per VMEbus chassis.

Block Diagram

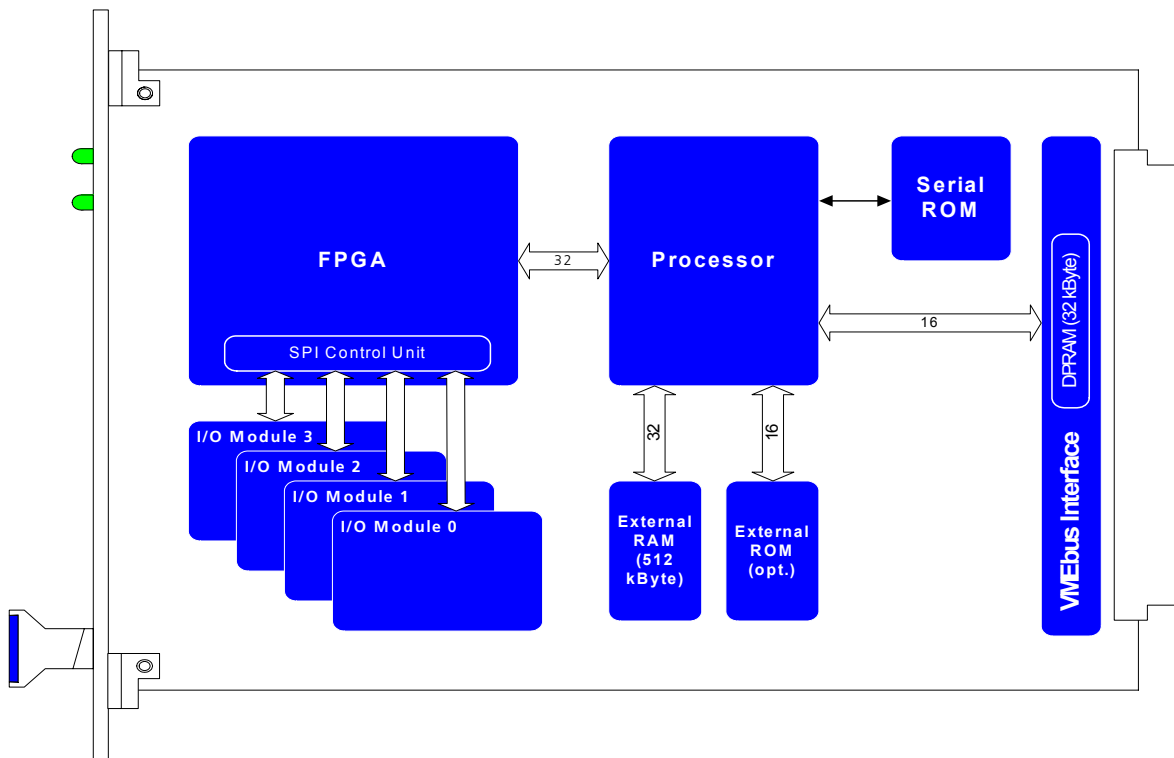

Technical Specifications

Names	Features
Configuration	4 sockets
Supported types of I/O module	PB1651xxx and PB4350xxx
I/O module interrupt to VMEbus	Yes
Environment	
Operating temperature	5 °C to 35 °C (41 °F to 95 °F)
Operating humidity	To 95% non-condensing
Isolation	Non-isolated

Contact Addresses

ETAS GmbH
70469 Stuttgart, Germany
Phone +49 711 89661-102
Fax +49 711 89661-106
sales.de@etas.com

ETAS S.A.S.
94588 Rungis Cedex, France
Phone +33 1 56 70 00 50
Fax +33 1 56 70 00 51
sales.fr@etas.com

ETAS Ltd.
Burton-upon-Trent
Staffordshire DE14 2WQ
Great Britain
Phone +44 1283 54 65 12
Fax +44 1283 54 87 67
sales.uk@etas.com

ETAS Inc.
Ann Arbor, MI 48103, USA
Phone +1 888 ETAS INC
Fax +1 734 997-9449
sales.us@etas.com

ETAS K.K.
Yokohama 220-6217, Japan
Phone +81 45 222-0900
Fax +81 45 222-0956
sales.jp@etas.com

ETAS Korea Co., Ltd.
Seoul 137-889, Korea
Phone +82 2 57 47-016
Fax +82 2 57 47-120
sales.kr@etas.com

ETAS (Shanghai) Co., Ltd.
Shanghai 200120, P.R. China
Phone +86 21 5037 2220
Fax +86 21 5037 2221
sales.cn@etas.com

ETAS Automotive India Pvt. Ltd
Bangalore 560 068, India
Phone +91 80 4191 2588
Fax +91 80 4191 2586
sales.in@etas.com

www.etas.com

Subject to change (2/2009)

Ordering Information

Order Name	Short Name	Order Number
ES1651.1-B Carrier Board (4 Sockets)	ES1651.1-B	F-00K-106-462